

Sumitomo Drive Technologies
Always on the Move

Cyclo[®]BBB

BEVEL BUDDYBOX

Speed Reducers and Gearmotors
featuring Keyless Taper-Grip[®] Bushing

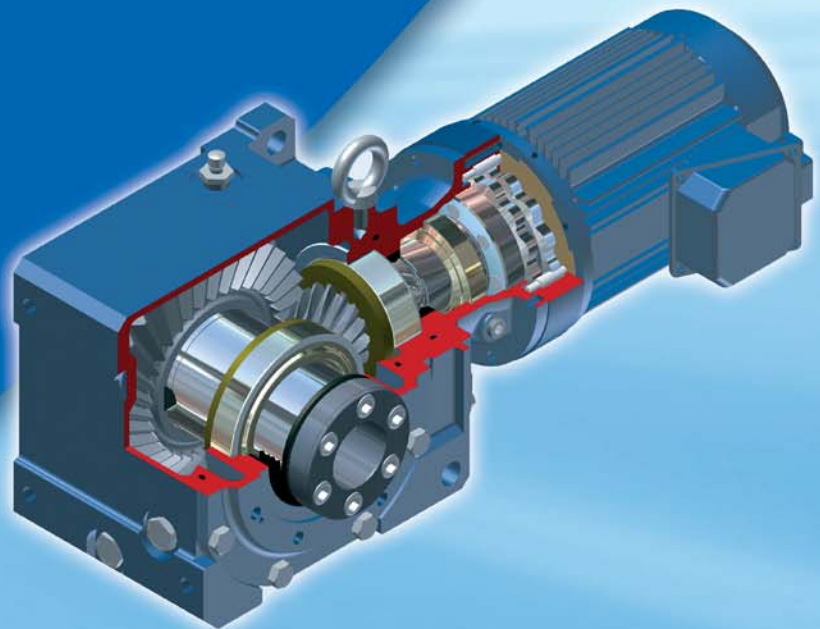

CATALOG 13.601.50.003

Cyclo[®]BBB

BEVEL BUDDYBOX

Sumitomo Drive Technologies
Always on the Move

Speed Reducers and Gearmotors featuring Keyless Taper-Grip[®] Bushing

Cycloidal Input

Provides high overload capability and exceptional reliability for long life.

Modular Design

Simplifies drive systems; common parts reduce spares inventories, saves money.

Compact

Space savings, even for high ratios, with no thermal limitations.

High Performance

All steel reduction parts provide efficiencies of 85 – 90% across the entire ratio range.

Double Output Seals Standard

Prevent leaks, keep lubricant in, keep dirt out. Plunge ground seal journals extend seal life.

Complete Range of Ratios

Ratios from 11:1 through more than 26,000:1.

Flexible Mounting

Available in hollow shaft, foot, flange and face mounts to optimize drive arrangement. Integral motor, C-face and shovel base models available.

Steel Taper Grip[®] Keyless Shaft Bushing

Easy mounting of hollow shaft units saves time and money. Optional keyed hollow shafts available upon request.

Rugged Cast Iron Housing

Rigid, corrosion resistant and sound dampening; grey iron housings extend service life by maintaining precise gear alignment.

Full 24 Month Warranty

Not limited by operational hours or duty cycle.

Ready Availability

Stocked at regional Cyclo centers.

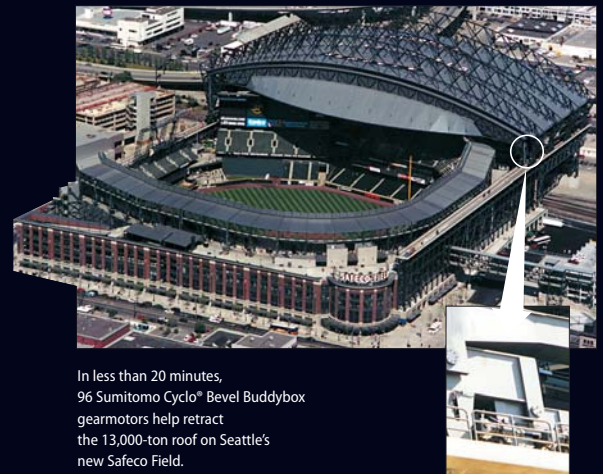
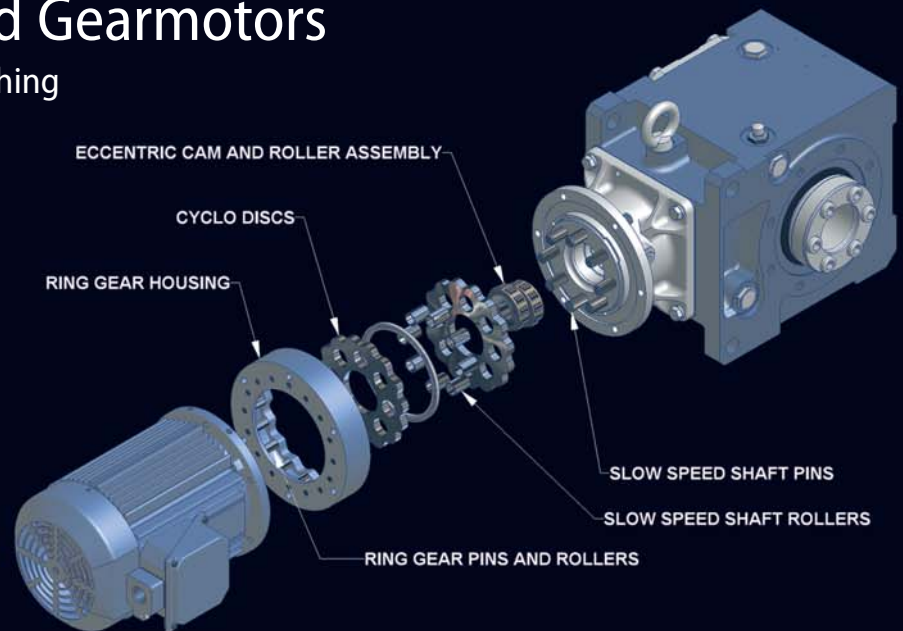

In less than 20 minutes, 96 Sumitomo Cyclo[®] Bevel Buddybox gearmotors help retract the 13,000-ton roof on Seattle's new Safeco Field.

The Sumitomo gearmotors, on eight travel truck assemblies, turn 128 36" wheels.

The cover image and other artwork are for illustration purposes only. The Steel Taper-Grip[®] bushing will be mounted on the opposite flange side.

Cyclo[®] BBB BEVEL BUDDYBOX

Speed Reducers and Gearmotors featuring Keyless Taper-Grip[®] Bushing

Table of Contents

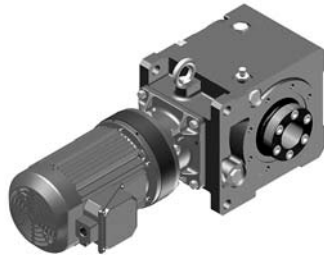
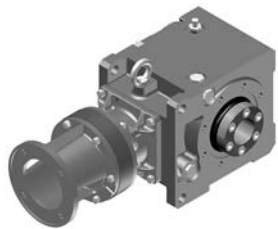

1. General Information

2. Speed Reducers

How to Select	2.2
Configure a Model Number (Nomenclature)	2.4
AGMA Load Classifications	2.6
Selection Tables	2.8
Single Reduction	2.8
Horizontal Mounting	2.8
Vertical Mounting	2.12
Double Reduction	2.16
Dimensions	2.22

3. Gearmotors

How to Select	3.2
Configure a Model Number (Nomenclature)	3.4
AGMA Load Classifications	3.6
Selection Tables	3.8
Horizontal Mounting	3.8
Vertical Mounting	3.28
Dimensions	3.38

4. Options

5. Appendices

Special Load Guidelines	5.2
Taper-Grip [®] Bushing	5.7
Parts List	5.8
Motor Characteristics	5.12
Brakemotor Characteristics	5.13
Standard Wiring	5.15
Lubrication	5.16
Installation	5.18
Warranty	5.19

Cyclo[®] BBB

BEVEL BUDDYBOX

Sumitomo Drive Technologies
Always on the Move

Speed Reducers and Gearmotors featuring Keyless Taper-Grip[®] Bushing

Cyclo[®] Quality and Reliability, Right Angle Design

Product Description

Sumitomo's Cyclo[®] Bevel Buddybox (Cyclo[®] BBB) combines the long-proven Cyclo[®] gear reducer and a single stage right angle spiral bevel gearbox in a rugged integral, shaft-mounted design. The Cyclo[®] BBB incorporates the strength and flexibility of the Cyclo[®] reducer with the adaptability of a shaft-mounted, right angle reducer. With a 24-month warranty, regardless of hours of operation, the Cyclo[®] BBB is an excellent choice for applications in material handling, asphalt mixers, speciality machine industries, conveyors, and other applications requiring right angle orientation of speed reducers.

Features & Benefits

- Cycloidal input and oversized bevel gearing provides high overload capability and exceptional reliability for long life
- High performance steel gearing components provide 85-90% efficiency across all ratios
- Steel Taper-Grip[®] keyless shaft bushing allows for easy cost-effective mounting of hollow shaft units
- Double output seals prevent leaks, maintain optimum lubrication and prevent harmful infiltration of contaminants
- Compact, space-saving design with no thermal limitations

Specifications Summary

Ratios:	11:1 up to 26,000:1 and greater
Torque Capacity:	Up to 94,700 in. lbs.
HP:	1/8 to 40
Mounting:	Hollow Shaft, Foot, Flange, Face
Options:	Integral Motor, C-Face and Shovel Base
Available Standards:	NEMA, IEC, JIS, UL, CSA, CE

Flexible mounting configurations available in hollow shaft, foot, flange, and face mounts to optimize drive arrangement

Double output seals prevent lubricant leaks and protect from contamination

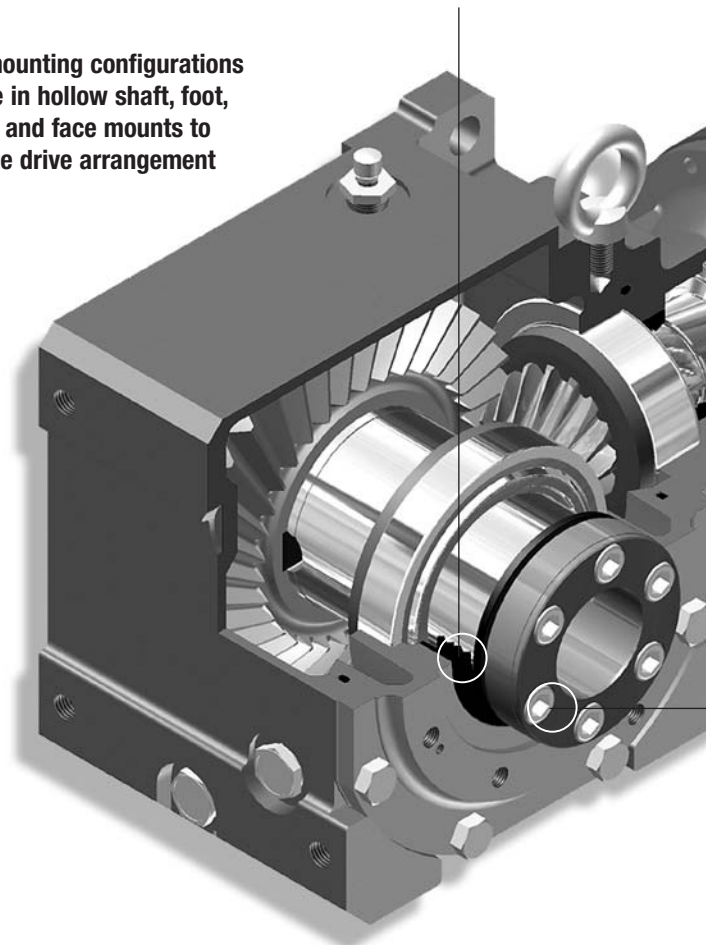

Applications

- Material Handling
- Casting Conveyors
- Capstan Drive
- Rolling Mill Table
- Wire Drawing Machines
- Food Processing
- Asphalt Mixers
- Printing Plant
- Belt Filter Press
- Shredders/Compactors
- Chip Conveyors



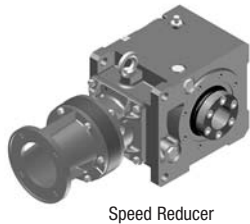

Speed Reducer

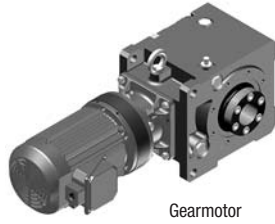

Gearmotor

Cycloidal input provides high overload capability and exceptional reliability over long life

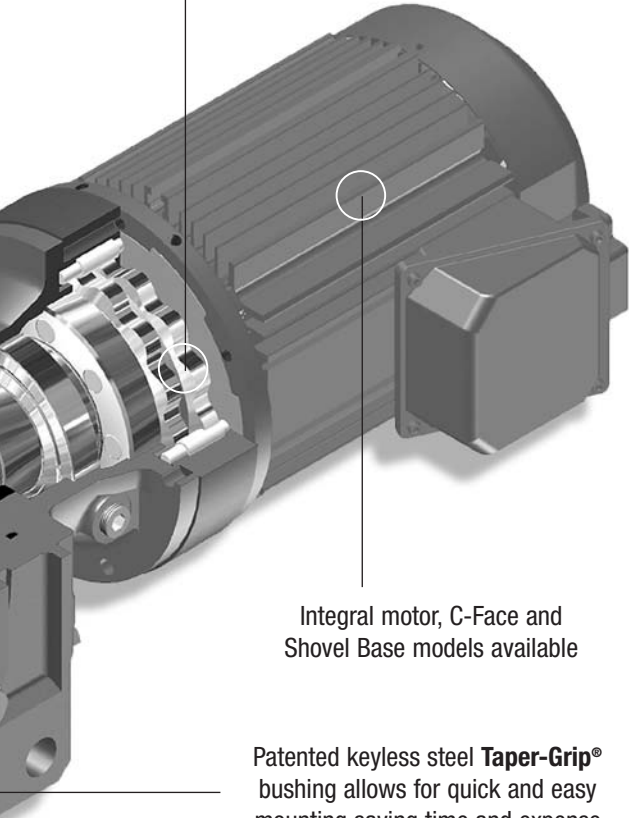

Integral motor, C-Face and Shovel Base models available

Patented keyless steel **Taper-Grip®** bushing allows for quick and easy mounting saving time and expense

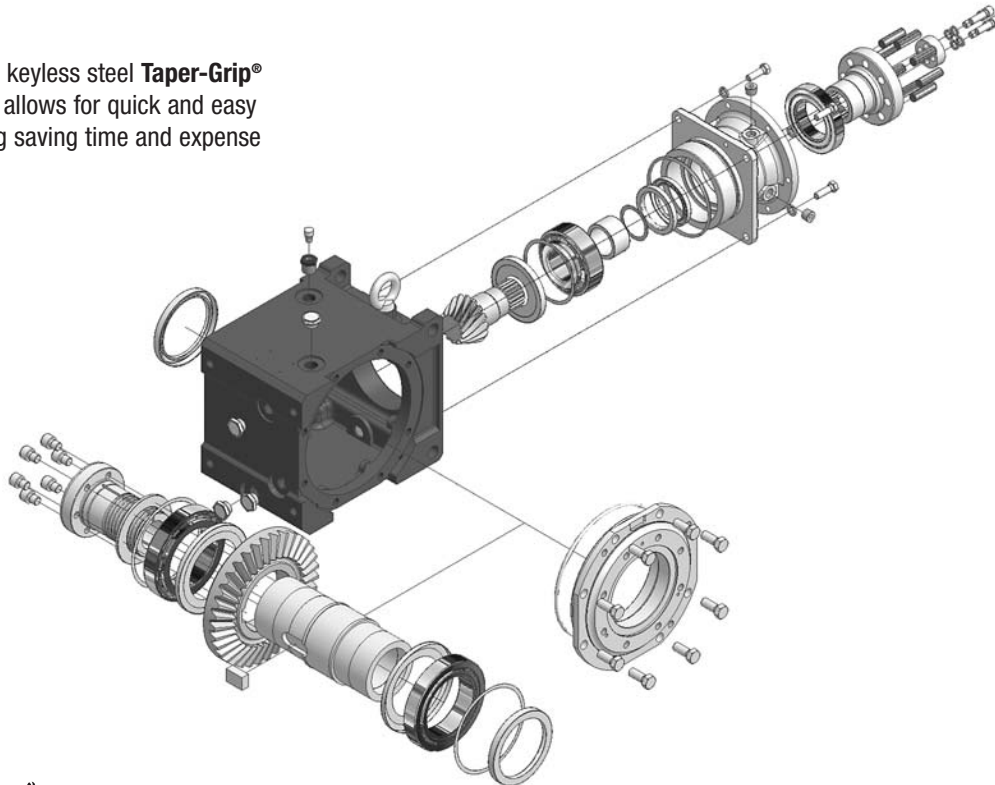

Taper-Grip® Bushing

The Sumitomo **Taper-Grip®** bushing is a keyless (shrink disc type) shaft/hub locking device integrated into the shaft mounted right angle (Cyclo BBB) reducer and gearmotor product lines.

The unique patented design has a number of benefits for the user:

- “Easy on and easy off” mounting and removal of the drive to and from the shaft of the driven machine.
- Requires no shaft preparation such as a keyway, undercut, or keeper plate.
- No key required for torque transmission.
- Backlash free torque transmission.
- No shaft weakening by a key way.
- Tight tolerance not required for shaft machining.
- Automatic axial fixation of the drive on the shaft in any position.
- Shaft can be adjusted prior to final mounting in any position.



Standard Specifications

	Standard Specifications	Standard Specifications with Built-In Brake	
3-Phase Integral Motor	Capacity Range:	1/8 HP ~ 40 HP, 4P	1/8 HP ~ 15 HP, 4P: FB Brake 20 HP, 4P: CMB Brake 25 HP ~ 40 HP, 4P: ESB Brake
	Enclosure:	Totally enclosed fan cooled type (1/8 HP, 4P Totally enclosed non ventilated)	Totally enclosed fan cooled type (1/8 HP, 4P Totally enclosed non ventilated)
	Power Supply:	230/460 Volts, 60 Hz 575 Volts, 60 Hz	230/460 Volts, 60 Hz 575 Volts, 60 Hz
	Insulation:	3/4 ~ 30 HP: Class B 40 HP: Class F	3/4 ~ 20 HP: Class B
	Time Rating	Continuous	Continuous

Reducer	Reduction:	Combination of Cyclo input and right angle spiral bevel gear output.
	Lubrication:	Cyclo portion is grease or oil lubricated; Bevel portion is oil lubricated.
	Seals:	Nitrile material, dual lipped, double output seals.
	Material:	Rugged cast iron housings
	Paint Color:	Blue, Muenters color number 6.5PB 3.6/8.2
	Bearings:	Tapered roller bearings on geared output; ball bearings on Cyclo input.

Ambient Conditions	Installation Location:	Indoors (Minimal dust and humidity)
	Ambient Temperature:	14°~104° F (-10° ~ 40° C)
	Ambient Humidity:	Under 85%
	Elevation:	Under 3,281 ft. (1000 meters)
	Atmosphere:	Well ventilated location, free of corrosive gases, explosive gases, vapors and dust.

Shaft Rotation

On single reduction Cyclo BBB speed reducers, ratios 11 through 305, the slow speed shaft rotates in a reverse direction to that of the high speed shaft.

On double reduction units, ratios 357 through 26,492, both the high speed and the slow speed shaft rotate in the same direction.

Input Speeds

In general terms, the standard input speeds of single reduction units are 1750 and 1165 RPM. When non-standard input speeds are used, the horsepower and torque ratings will also vary.

Thermal Capacity

The Cyclo BBB speed reducer's smooth, almost frictionless operation all but eliminates the conventional limitations due to heat. In all sizes, SM-Bevel Buddybox speed reducers have thermal ratings that exceed their mechanical capacity.

How do I select a Cyclo BBB speed reducer or gearmotor?

Selection is based on the actual horsepower and/or torque requirements at the output shaft. The Cyclo BBB speed reducer has particularly high efficiencies over a wide range of reduction ratios, which frequently permits the use of reduced input power requirements (smaller HP motor) without sacrificing output shaft torque. The selection procedures in this catalog will guide you in choosing the most efficient reducer for your application.

What information do I need to get started in the selection process?

To select the proper reducer for your application, you will need to know:

- Application: type of driven machine
- Hours of operation per day
- Motor horsepower (HP) and speed (RPM)
- Mounting position

If there are any special environmental factors or operation requirements, they must also be noted. This information will be important in determining the Service Factor of your application.

What are Service Factors and how are they used?

In general, reducers and gearmotors are rated for the specific conditions and operating requirements of the application by the use of AGMA-defined Service Factors. There are three AGMA load classifications for reducers: uniform (U), moderate shock (M) and heavy shock (H) (page 2.6) and three AGMA load classifications for gearmotors: I, II and III (pages 3.6–3.7). The Service Factors are used in the product selection process to adjust for the specific conditions and operating requirements of your application.

What do I do if my application has particularly severe operating conditions?

The standard ratings for Cyclo BBB are based on 10-hour daily service under conditions of uniform loads (equivalent to AGMA service factor 1.0). By following the product selection process, you will determine and apply the Service Factors to compensate for the severe operating conditions.

How can I be sure that the reducer can withstand periodic excessive overloads?

Cyclo BBB Speed Reducers provide 300% momentary intermittent shock load capacity. For applications with shock loads greater than 300%, consult an SMA Application Engineer.

What are the standard input speeds?

In general terms, the speeds are 1750 and 1165 RPM. The selection tables in this catalog are based on 1750 RPM. When non-standard input speeds are used, the horsepower and torque ratings also vary.

What thermal capacity limitations does the Cyclo BBB have?

The Cyclo speed reducer, by virtue of its smooth, almost frictionless operation (unlike traditional helical gears), has a thermal rating that far exceeds its mechanical capacity and all but eliminates the conventional limitations due to heat.

What are the advantages of the Taper-Grip® bushing?

The Taper-Grip® bushing is integral to the Cyclo BBB and provides for easy mounting and removal to and from the shaft of the driven machine. Because it requires no key way, the shaft isn't weakened and maximum torque is transmitted.

What are the advantages of the new Steel Taper-Grip® bushing?

With an increased torque capacity, the new Steel Taper-Grip® bushing can be used in reversing and/or high start-up applications. The new Steel Taper-Grip® bushing can be used on all Taper-Grip® products.

What kind of torque arm do I specify? At what position should I mount it?

The standard torque arm assembly supplied is a turnbuckle type as shown on page 4.4. The torque arm should be mounted at 90 degrees to a line from the point of attachment to the reducer and the center of the output bore with up to 30 degrees plus or minus variance. A bracket type torque arm is also offered as a non-stock option.

Mounting Positions

For additional mounting configurations, please check the SMA Website at www.sumitomodrive.com or consult the factory.

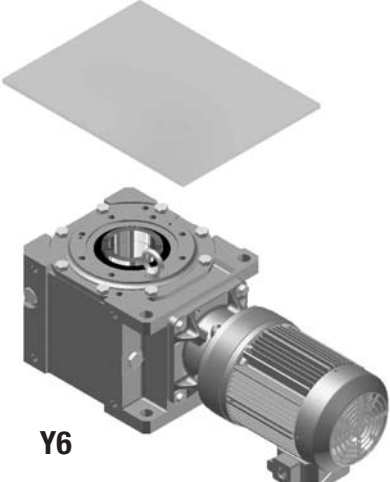
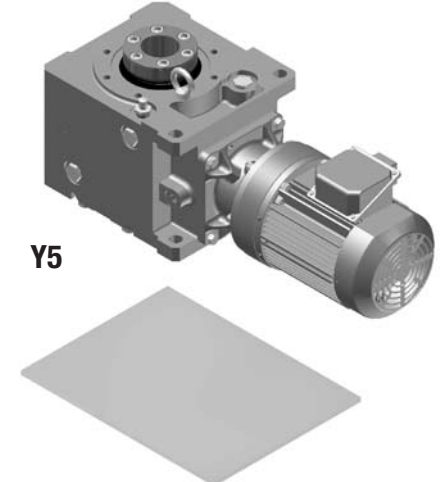
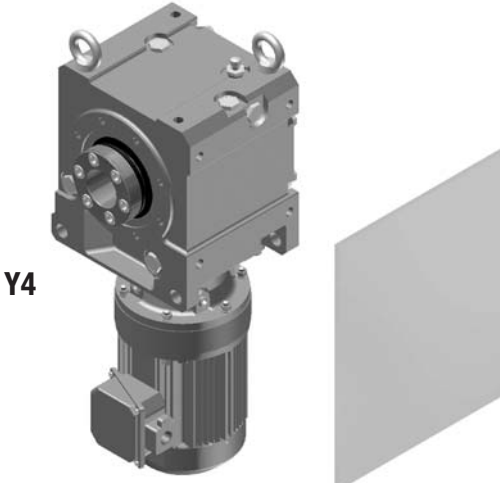
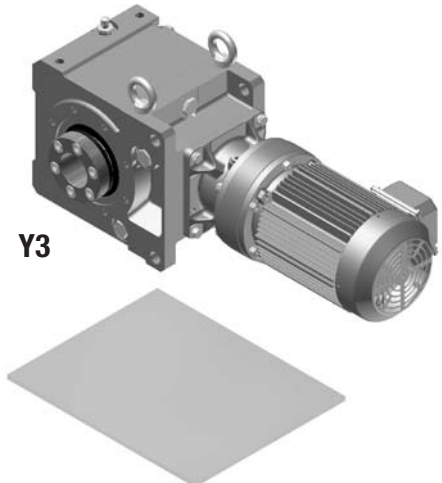
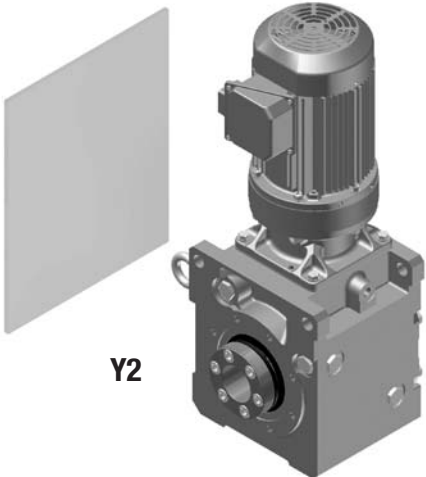
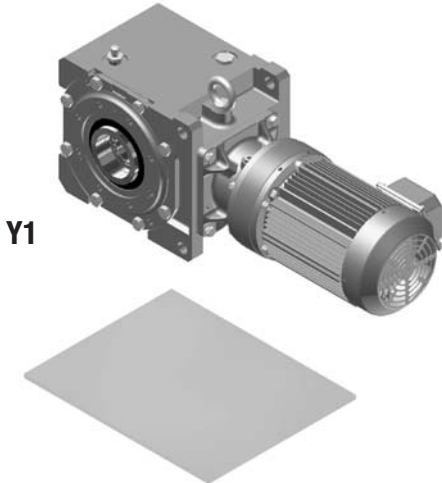

2

Speed Reducers

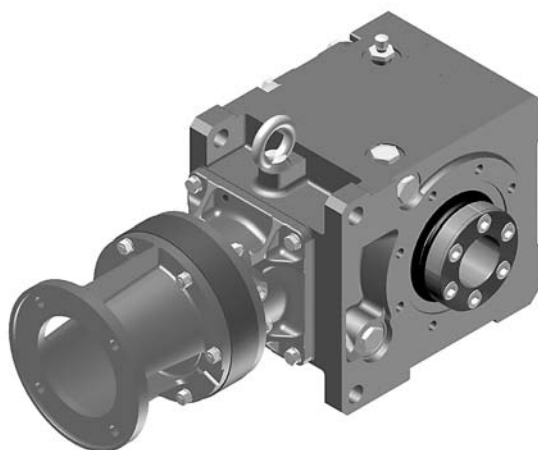

How to select a Speed Reducer

Step 1: Collect data about your application

Before starting you need to know the:

- Application (e.g. Conveyor, Mixer, etc.)
- Hours of Operation per day
- Motor Horsepower (HP) and Speed (RPM)
- Desired Output Speed
- Mounting Position and Style
- Overhung or Thrust Loads
- Bore Dimensions, inch or metric

Step 2: Choose a Mounting Position

Find the correct Mounting Position from the *Mounting Positions Table* on the right.

Step 3: Select a Frame Size

2A: Find the **Load Classification** of your application in the *AGMA Load Classification Table* on page 2.6.

2B: Find the recommended **Service Factor** using the *Recommended Reducer Service Factor Table* on the right.

2C: Determine the **Selection Horsepower** by multiplying the Motor Horsepower by the Service Factor.

2D: Select a **Frame size** from the Reducer Selection Tables on pages 2.8–2.21 by matching both the Selection Horsepower and Desired Output Speed (RPMs) to a frame size model number. Note: For Mounting Positions Y1, Y3, Y5, Y6 see pages 2.8–2.11. For Mounting Positions Y2 and Y4 see pages 2.12–2.15.) For all Double Reduction Mounting Positions see pages 2.16–2.21.

Step 4: Verify Dimensions

Use the Dimensions information on pages 2.22–2.25 to verify that the selected Frame Size is appropriate.

Step 5: Choose a Bushing Bore Size

Choose a Taper Grip Bushing Bore Size from the *Stock Bushing Bore Size Table*.

Step 6: Choose Options

The following options may apply:

- Washdown Modification
- Breather
- Cover Guard

Please see the *Cyclo BBB pricelist*, or visit our website at www.smcyclo.com for available modifications.

Step 7: Configure a Model Number

Go to page 2.4 to configure a model number.

Note: You will use the information you gather from the procedure on this page to Configure a Model Number.

STOCK BUSHING BORES

Size	Inch Sizes	Metric Sizes	Min. Bore
A	1 ¹⁵ / ₄₁₆ , 2 ³¹ / ₄₁₆	50, 55	1 ¹¹ / ₄₁₆
B	2 ³¹ / ₄₁₆ , 2 ⁷¹ / ₄₁₆	60, 65	1 ¹⁵ / ₄₁₆
C	2 ⁷¹ / ₄₁₆ , 2 ¹⁵¹ / ₄₁₆	65, 75	2 ³¹ / ₄₁₆
D	2 ¹⁵¹ / ₄₁₆ , 3 ⁷¹ / ₄₁₆	75, 85	2 ⁷¹ / ₄₁₆
E	3 ⁷¹ / ₄₁₆ , 3 ¹⁵¹ / ₄₁₆	90, 100	2 ¹⁵¹ / ₄₁₆

**Min. Bore is also stock but needs slitting.



Mounting Positions

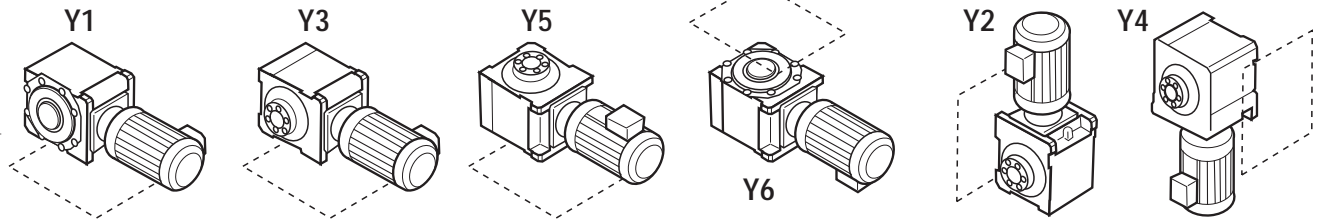

Recommended Reducer Service Factors

AGMA Load Classifications

	Uniform (U)	Moderate Shock (M)	Heavy Shock (H)
1/2 hr. per day (Occasional)	0.50*	0.80*	1.25
3 hrs. per day (Intermittent)	0.80*	1.00	1.50
Up to 10 hrs. per day	1.00	1.25	1.75
24 hrs. per day	1.20	1.50	2.00

*Maximum momentary or starting load must not exceed 300% of gear reducer rating (rating meaning service factor of 1.0). Time specified for occasional and intermittent service refers to total operating time per day.

Speed Reducers

How to Select

Determine Selection Horsepower (HP)

$$\text{Motor HP} \times \text{Service Factor} = \text{Selection HP}$$

Example: 10 Motor HP X 1.25 Service Factor = 12.5 Selection HP

Select a Frame Size

1 Match your OUTPUT RPM (or RATIO)...

Output RPM	159	97.2	83.3	62.5	44.9	38.0	33.0	29.2	23.6	Frame Size
Ratio	11	18	21	28	39	46	53	60	74	
Input HP	3.15	3.15		3.15	3.15	3.15	3.15	2.67	2.59	2A100
Output Torque (in•lbs)	1149	1879		2922	4068	4806	5535	5302	6363	
Hollow Shaft OHL (lbs)	1120	1120		1120	1120	1120	1120	1120	1120	
Solid Shaft OHL (lbs)	990	990		990	990	990	990	990	990	
Input HP	4.26	4.26						3.30	3.14	2A105
Output Torque (in•lbs)	1554	2541						6553	7715	
Hollow Shaft OHL (lbs)	1120	1120						1120	1120	
Solid Shaft OHL (lbs)	990	990						990	990	
Input HP	-	-	4.76							2A110
Output Torque (in•lbs)	-	-	3212					8459	8968	
Hollow Shaft OHL (lbs)	-	-	1120					1120	1120	
Solid Shaft OHL (lbs)	-	-	990					990	990	
Input HP	-	-	5.26	5.26	5.26	5.26	5.26	4.79	3.88	2A115
Output Torque (in•lbs)	-	-	3661	4880	6793	7980	9189	9512	9533	
Hollow Shaft OHL (lbs)	-	-	1120	1120	1120	1120	1120	1120	1120	
Solid Shaft OHL (lbs)	-	-	990	990	990	990	990	990	990	
Input HP	6.80	6.80	6.80	6.80	6.80	-	-	-	-	2A120
Output Torque (in•lbs)	9490	4652	4792	6200	8784	-	-	-	-	

2 ...to your SELECTION HP...

3 ...to find your FRAME SIZE

If Overhung Load is present, any Overhung Load must be checked against the capacity of the selection.



For special circumstances in selecting a Frame Size such as:

- Overhung Load
- Thrust Loads
- Radial Loads
- Shock Loading

Consult Appendix, pages 5.2–5.6.

Configure a Model Number

Speed Reducers
Nomenclature

Output Shaft Orientation

Type	Prefix
Horizontal	H
Vertical	V
Vertical Up (Solid Shaft)	W

Mounting Style

Type	Prefix
Shaft Mount (Hollow Shaft)	Y
Flange (Solid Shaft)	F
Foot (Solid Shaft)	H

Input Connection

Input Connection	Prefix	
	Reducer	Gearmotor
Integral Motor		
Free input Shaft		
C-Face Adaptor	J	JM
Hollow Input Shaft (Size A Only)	X	XM

Modification

	Prefix
Special	S
Standard	

Gearmotor HP (applies only to 1750 RPM)

HP	Prefix
1/8	01
1/4	02
1/3	03
1/2	05
3/4	08
1	1
1 1/2	1H
2	2
3	3
5	5
7 1/2	8
10	10
15	15
20	20
25	25
30	30
40	40

When ordering, the following information should be included:

- Motor Specification (230/460 VAC 60 Hz is supplied, unless otherwise specified)
- NEMA frame size for C-face adaptor
- Bushing Bore size must be supplied

Optional conduit box positions must be specified, otherwise Y1 is supplied.

Frame Size

Single Reduction				
2A100	2A140	2B145	2C160	2D165
2A105	2A145	2B160	2C165	2D170
2A110	2B120	2B165	2C170	2D175
2A115	2B125	2C140	2C175	2E170
2A120	2B140	2C145	2D160	2E175
2A125				
Double Reduction				
2A10DA	2B14DA	2C14DC	2D16DB	2D17DC
2A12DA	2B14DB	2C16DA	2D16DC	2E17DA
2A12DB	2C14DA	2C16DB	2D17DA	2E17DB
2B12DA	2C14DB	2D16DA	2D17DB	2E17DC
2B12DB				

L H Y J S

Gearmotor HP
(1750 rpm)

2 A 1 0 5

Frame size

Y

Y1

207

Ratio

Modification (Special feature)

Input connection

Mounting style

Output shaft orientation

Cyclo BBB product code (always "L")

O/P shaft direction (shafted model only)

Shaft specification

Mounting position and optional specification
(as required)

Nomenclature

Output Shaft Direction (Shafted Model Only)

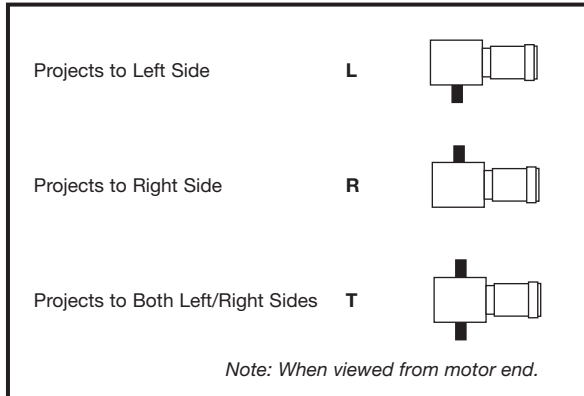

Shaft Specifications

Input Shaft	OUTPUT SHAFT		Suffix
	Hollow	Solid	
mm	Key (mm)	mm	
DIN	Key (DIN)	DIN	E
Inch	Key (Inch)	Inch	K
mm	Taper Grip		M
DIN	Taper Grip		G
Inch	Taper Grip		Y

Nominal and Exact Ratio

BBB with Planetary Input			
Input Ratio	Nominal Ratio	BBB Frame Sz.	Exact Ratio
3.00	11	2A10	10.500
N/A	N/A	2A11	N/A
3.00	11	2A12	10.500
3.11	11	2A14	10.885
3.00	11	2B12	10.500
3.11	11	2B14	10.885
3.10	11	2B16	10.850
3.11	11	2C14	10.885
3.10	11	2C16	10.850
3.10	11	2C17	10.850
3.10	11	2D16	10.850
3.10	11	2D17	10.850
3.10	11	2E17	10.850
4.80	18	2A10	16.800
N/A	N/A	2A11	N/A
4.89	18	2A12	17.115
5.00	18	2A14	17.500
4.89	18	2B12	17.115
5.00	18	2B14	17.500
5.08	18	2B16	17.780
5.00	18	2C14	17.500
5.08	18	2C16	17.780
5.05	18	2C17	17.675
5.08	18	2D16	17.780
5.05	18	2D17	17.675
5.05	18	2E17	17.675

BBB with Cyclo Input			
Input Ratio	Single Reduction		Exact Ratio
	Nominal Ratio	BBB Frame Sz.	
6	21		21.0
8	28		28.0
11	39		38.5
13	46		45.5
15	53		52.5
17	60		59.5
21	74		73.5
25	88	ALL	87.5
29	102		101.5
35	123		122.5
43	151		150.5
51	179		178.5
59	207		206.5
71	249		248.5
87	305		304.5
Input Ratio	Double Reduction		Exact Ratio
	Nominal Ratio	BBB Frame Sz.	
104	364		364.0
121	424		423.5
143	501		500.5
165	578		577.5
195	683		682.5
231	809		808.5
273	956		955.5
319	1117		1116.5
377	1320		1319.5
473	1656		1655.5
559	1957		1956.5
649	2272		2271.5
731	2559		2558.5
841	2944	ALL	2943.5
1003	3511		3510.5
1247	4365		4364.5
1479	5177		5176.5
1849	6472		6471.5
2065	7228		7227.5
2537	8880		8879.5
3045	10568		10657.5
3481	12184		12183.5
4437	15530		15529.5
5133	17966		17965.5
6177	21620		21619.5
7569	26492		26491.5

Speed

Nomenclature

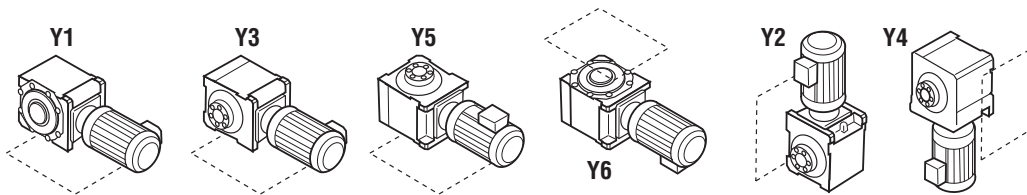

Mounting Positions

Nominal and Exact Ratio

Nomenclature Example:

LHYJ - 2B125Y - Y1 - 60

- L** - Cyclo Bevel Buddybox
- H** - Horizontal O/P
- Y** - Shaft Mount (Hollow Shaft)
- J** - C-Face Input
- 2B125** - Frame Size
- Y1** - Installation Position
- 60** - Ratio

AGMA Load Classifications

Speed Reducers
AGMA Tables

TYPE OF APPLICATION	TYPE OF LOAD	TYPE OF APPLICATION	TYPE OF LOAD	TYPE OF APPLICATION	TYPE OF LOAD
Agitators		Large (industrial)	M	Paper Mills	
Pure liquids	U	Light (small diameter)	U	Agitators (mixers)	M
Liquids and solids	M	Feeders		Barker, hydraulic	M
Variable-density liquids	M	Apron	M	Barker, mechanical	M
Blowers		Belt	M	Barking drum	H
Centrifugal	U	Disc	U	Beater and pulper	M
Lobe	M	Reciprocating	H	Bleacher	U
Vane	U	Screw	M	Calenders	M
Brewing and Distilling		Food Industry		Calenders, super	H
Bottling machinery	U	Beet slicer	M	Converting machine (except cutters, platers)	M
Brew kettles, cont. duty	U	Cereal cooker	U	Conveyors	U
Cookers, cont. duty	U	Dough mixer	M	Couch	M
Mash tubs, cont. duty	U	Meat grinders	M	Cutters, platers	H
Scale hopper, frequent starts	M	Generators (Not Welding)	U	Cylinders	M
Can Filling Machines	U	Hammer Mills	H	Dryers	M
Cane Knives	M	Hoists		Felt stretcher	M
Car Dumpers	H	Heavy duty	H	Felt whipper	H
Car Pullers	M	Medium duty	M	Jordans	H
Clarifiers	U	Skip	M	Log haul	H
Classifiers	M	Laundry Washers — Reversing	M	Presses	U
Clay Working Machinery		Laundry Tumblers — Reversing	M	Pulp machine reel	M
Brick press	H	Line Shaft		Stock chest	M
Briquette machine	H	Drive processing equipment	M	Suction roll	U
Clay working machinery	M	Light	U	Washers and thickeners	M
Pug mill	M	Other line shafts	U	Winders	U
Compressors		Lumber Industry		Printing Presses	S
Centrifugal	U	Barkers — hydraulic and mechanical	S	Pullers, Barge Haul	H
Lobe	M	Burner conveyor	M	Pumps	
Reciprocating, multi-cylinder	M	Chain Saw and Drag Saw		Centrifugal	U
Reciprocating, single-cylinder	H	Chain transfer	H	Proportioning	M
Conveyors — Uniformly Loaded or Fed		Craneway transfer	H	Reciprocating	
Apron	U	De-barking drum	H	Single acting, 3 or more cylinders	M
Assembly	U	Edger feed	H	Double acting, 2 or more cylinders	M
Belt	U	Gang feed	M	Rotary-gear type	U
Bucket	U	Geen chain	M	Rubber and Plastics Industries	
Chain	U	Live rolls	H	Crackers	H
Flight	U	Log haul-lockline	H	Laboratory equipment	M
Oven	U	Log turning device	H	Mixing mills	H
Screw	U	Main log conveyor	M	Refiners	M
Conveyors — Heavy Duty, Not Uniformly Fed		Off bearing rolls	M	Rubber calenders	M
Apron	M	Planer feed chains	M	Rubber mill (2 on line)	M
Assembly	M	Planer floor chains	M	Rubber mill (3 on line)	U
Belt	M	Planer tilting hoist	M	Sheeter	M
Bucket	M	Re-saw merry-go-round conveyor	M	Tire building machines	S
Chain	M	Roll cases	H	Tire and tube press openers	S
Flight	M	Slab conveyor	H	Tubers and strainers	M
Live roll oven	M	Small waste-conveyor-belt	U	Warming mills	M
Reciprocating	H	Small waste-conveyor-chain	M	Sand Muller	M
Screw	M	Sorting table	M	Screens	
Shaker	H	Tipple hoist conveyor	M	Air washing	U
Cranes (Except for Dry Dock Cranes)		Tipple hoist drive	M	Rotary, stone or gravel	M
Main hoists	U	Transfer conveyors	M	Traveling water intake	U
Bridge travel	S	Transfer rolls	M	Sewage Disposal Equipment	
Trolley travel	S	Tray drive	M	Bar screens	U
Crusher		Trimmer feed	M	Chemical fenders	U
Ore	H	Waste conveyor	M	Collectors, circuline or straightline	U
Stone	H	Machine Tools		Dewatering screens	M
Sugar	M	Bending roll	M	Grit collectors	U
Dredges		Notching press, belt driven	S	Scum breakers	M
Cable reels	M	Plate planer	H	Slow or rapid mixers	M
Conveyors	M	Punch press, gear driven	H	Sludge collectors	U
Cutter head drives	H	Tapping machine	H	Thickeners	M
Jig drives	H	Other machine tools		Vacuum filters	M
Maneuvering winches	M	Main drives	M	Slab Pushers	M
Pumps	M	Auxiliary drives	U	Steering Gear	S
Screen drive	H	Metal Mills		Stokers	
Stackers	M	Draw bench carriage and main drive	M	U	
Utility winches	M	Forming machines	H	Sugar Industry	
Dry Dock Cranes	S	Pinch, dryer and scrubber rolls, reversing	S	Cane knives	M
Elevators		Slitters	M	Crushers	M
Bucket, uniform load	U	Table conveyors, nonreversing		Mills	H
Bucket, heavy load	M	Group drives	M	Textile Industry	
Bucket, cont.	U	Individual drives	H	Batchers	M
Centrifugal discharge	U	Table conveyors, reversing	S	Calenders	M
Escalators	U	Wire drawing and flattening machine	M	Cards	M
Freight	M	Wire winding machine	M	Dry cans	M
Gravity discharge	U	Mills, Rotary Type		Dryers	M
Man lifts	S	Ball	M	Dyeing machinery	M
Passenger	S	Cement kilns	M	Knitting machines	S
Extruders (Plastics)		Dryers and coolers	M	Looms	M
Blow molders	M	Kilns	M	Mangles	M
Coating	U	Pebble	M	Nappers	M
Film	U	Rod, plain and wedge bar	M	Pads	M
Pipe	U	Tumbling barrels	H	Range drives	S
Pre-plasticizers	M	Mixers		Slashers	M
Rods	U	Concrete mixers, cont.	M	Soapers	M
Sheet	U	Concrete mixers, intermittent	M	Spinners	M
Tubing	U	Constant density	U	Tenter frames	M
Fans		Variable density	M	Washers	M
Centrifugal	U	Oil Industry		Winders	M
Cooling towers	S	Chillers	M	Windlass	S
Forced draft	S	Oil well pumps	S		
Induced draft	M	Paraffin filter press	M		
Large (mine, etc.)	M	Rotary kilns	M		

U = Uniform Load H = Heavy Shock
M = Moderate Shock S = Contact Sumitomo

This page intentionally left blank.

Frame Size Selection Tables 60 Hz, 1750 RPM

Single Reduction Y1, Y3, Y5, Y6 Mounting Positions

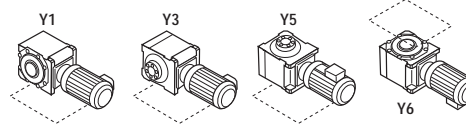

Dimensions on pages 2.22–2.23

Speed Reducers
Selection Tables

Output RPM	159	97.2	83.3	62.5	44.9	38.0	33.0	29.2	23.6	Frame Size
Ratio	11	18	21	28	39	46	53	60	74	
Input HP	3.15	3.15	3.15	3.15	3.15	3.15	3.15	2.67	2.59	2A100
Output Torque (in•lbs)	1149	1879	2193	2922	4068	4806	5535	5302	6363	
Hollow Shaft OHL (lbs)	1120	1120	1120	1120	1120	1120	1120	1120	1120	
Solid Shaft OHL (lbs)	990	990	990	990	990	990	990	990	990	
Input HP	4.26	4.26	4.26	4.26	4.26	4.26	4.26	3.30	3.14	2A105
Output Torque (in•lbs)	1554	2541	2965	3952	5501	6500	7485	6553	7715	
Hollow Shaft OHL (lbs)	1120	1120	1120	1120	1120	1120	1120	1120	1120	
Solid Shaft OHL (lbs)	990	990	990	990	990	990	990	990	990	
Input HP	-	-	4.76	4.76	4.76	4.76	4.76	4.26	3.65	2A110
Output Torque (in•lbs)	-	-	3313	4416	6147	7263	8364	8459	8968	
Hollow Shaft OHL (lbs)	-	-	1120	1120	1120	1120	1120	1120	1120	
Solid Shaft OHL (lbs)	-	-	990	990	990	990	990	990	990	
Input HP	-	-	5.26	5.26	5.26	5.23	5.23	4.79	3.88	2A115
Output Torque (in•lbs)	-	-	3661	4880	6793	7980	9189	9512	9533	
Hollow Shaft OHL (lbs)	-	-	1120	1120	1120	1120	1120	1120	1120	
Solid Shaft OHL (lbs)	-	-	990	990	990	990	990	990	990	
Input HP	6.80	6.80	6.80	6.80	6.80	-	-	-	-	2A120
Output Torque (in•lbs)	2480	4056	4733	6309	8781	-	-	-	-	
Hollow Shaft OHL (lbs)	1120	1120	1120	1120	1120	-	-	-	-	
Solid Shaft OHL (lbs)	990	990	990	990	990	-	-	-	-	
Input HP	7.79	7.79	7.79	9.32	7.40	6.26	5.43	-	-	2A125
Output Torque (in•lbs)	2841	4647	5422	8646	9556	9552	9541	-	-	
Hollow Shaft OHL (lbs)	1120	1120	1120	1120	1120	1120	1120	-	-	
Solid Shaft OHL (lbs)	990	990	990	990	990	990	990	-	-	
Input HP	17.4	-	-	-	-	-	-	-	-	2A140
Output Torque (in•lbs)	6345	-	-	-	-	-	-	-	-	
Hollow Shaft OHL (lbs)	1120	-	-	-	-	-	-	-	-	
Solid Shaft OHL (lbs)	990	-	-	-	-	-	-	-	-	
Input HP	20.2	14.8	12.3	10.1	-	-	-	-	-	2A145
Output Torque (in•lbs)	7366	8829	8562	9370	-	-	-	-	-	
Hollow Shaft OHL (lbs)	1120	1120	1120	1120	-	-	-	-	-	
Solid Shaft OHL (lbs)	990	990	990	990	-	-	-	-	-	
Input HP	-	-	-	-	-	6.80	6.80	6.80	5.31	2B120
Output Torque (in•lbs)	-	-	-	-	-	10376	11948	13503	13046	
Hollow Shaft OHL (lbs)	-	-	-	-	-	2070	2070	2070	2070	
Solid Shaft OHL (lbs)	-	-	-	-	-	1640	1640	1640	1640	
Input HP	-	-	-	-	7.94	7.94	7.94	7.59	6.54	2B125
Output Torque (in•lbs)	-	-	-	-	10254	12115	13951	15072	16068	
Hollow Shaft OHL (lbs)	-	-	-	-	2070	2070	2070	2070	2070	
Solid Shaft OHL (lbs)	-	-	-	-	1640	1640	1640	1640	1640	
Input HP	-	17.4	17.4	17.4	-	-	-	-	-	2B140
Output Torque (in•lbs)	-	10380	12112	16142	-	-	-	-	-	
Hollow Shaft OHL (lbs)	-	2070	2070	2070	-	-	-	-	-	
Solid Shaft OHL (lbs)	-	1640	1640	1640	-	-	-	-	-	
Input HP	-	20.2	20.2	20.1	14.7	12.5	10.8	9.5	7.72	2B145
Output Torque (in•lbs)	-	12050	14061	18647	18983	19073	18976	18864	18967	
Hollow Shaft OHL (lbs)	-	2070	2070	2070	2070	2070	2070	2070	2070	
Solid Shaft OHL (lbs)	-	1640	1640	1640	1640	1640	1640	1640	1640	
Input HP	27.2	27.2	-	-	-	-	-	-	-	2B160
Output Torque (in•lbs)	9919	16226	-	-	-	-	-	-	-	
Hollow Shaft OHL (lbs)	2070	2070	-	-	-	-	-	-	-	
Solid Shaft OHL (lbs)	1640	1640	-	-	-	-	-	-	-	

60 Hz, 1750 RPM Frame Size Selection Tables

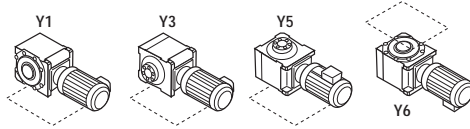

Single Reduction Y1, Y3, Y5, Y6 Mounting Positions

Dimensions on pages 2.22–2.23

Output RPM	19.9	17.2	14.2	11.6	9.8	8.45	7.03	5.74	Frame Size
Ratio	88	102	123	151	179	207	249	305	
Input HP	1.70	1.62	1.31	1.05	0.75	0.69	0.58	0.58	2A100
Output Torque (in•lbs)	4953	5461	5349	5248	4447	4735	4791	5859	
Hollow Shaft OHL (lbs)	1120	1120	1120	1120	1120	1120	1120	1120	
Solid Shaft OHL (lbs)	990	990	990	990	990	990	990	990	
Input HP	2.24	2.13	1.61	1.45	1.04	0.95	0.75	0.76	2A105
Output Torque (in•lbs)	6527	7180	6574	7248	6166	6519	6195	7677	
Hollow Shaft OHL (lbs)	1120	1120	1120	1120	1120	1120	1120	1120	
Solid Shaft OHL (lbs)	990	990	990	990	990	990	990	990	
Input HP	2.56	2.55	2.01	1.74	1.27	1.15	0.90	0.89	2A110
Output Torque (in•lbs)	7459	8596	8207	8697	7529	7891	7434	8990	
Hollow Shaft OHL (lbs)	1120	1120	1120	1120	1120	1120	1120	1120	
Solid Shaft OHL (lbs)	990	990	990	990	990	990	990	990	
Input HP	2.98	2.81	2.33	1.89	1.49	1.35	1.02	0.94	2A115
Output Torque (in•lbs)	8683	9473	9514	9447	8834	9264	8425	9495	
Hollow Shaft OHL (lbs)	1120	1120	1120	1120	1120	1120	1120	1120	
Solid Shaft OHL (lbs)	990	990	990	990	990	990	990	990	
Input HP	-	-	-	-	-	-	-	-	2A120
Output Torque (in•lbs)	-	-	-	-	-	-	-	-	
Hollow Shaft OHL (lbs)	-	-	-	-	-	-	-	-	
Solid Shaft OHL (lbs)	-	-	-	-	-	-	-	-	
Input HP	3.26	-	-	-	1.60	1.38	1.15	-	2A125
Output Torque (in•lbs)	9499	-	-	-	9486	9469	9499	-	
Hollow Shaft OHL (lbs)	1120	-	-	-	1120	1120	1120	-	
Solid Shaft OHL (lbs)	990	-	-	-	990	990	990	-	
Input HP	-	-	-	-	-	-	-	-	2A140
Output Torque (in•lbs)	-	-	-	-	-	-	-	-	
Hollow Shaft OHL (lbs)	-	-	-	-	-	-	-	-	
Solid Shaft OHL (lbs)	-	-	-	-	-	-	-	-	
Input HP	-	-	-	-	-	-	-	-	2A145
Output Torque (in•lbs)	-	-	-	-	-	-	-	-	
Hollow Shaft OHL (lbs)	-	-	-	-	-	-	-	-	
Solid Shaft OHL (lbs)	-	-	-	-	-	-	-	-	
Input HP	4.14	4.01	3.34	2.56	2.31	1.74	1.28	1.27	2B120
Output Torque (in•lbs)	12063	13518	13638	12796	13695	11940	10572	12829	
Hollow Shaft OHL (lbs)	2070	2070	2070	2070	2070	2070	2070	2070	
Solid Shaft OHL (lbs)	1640	1640	1640	1640	1640	1640	1640	1640	
Input HP	5.31	5.06	4.26	3.19	3.06	2.17	1.61	1.52	2B125
Output Torque (in•lbs)	15472	17058	17395	15945	18142	14890	13298	15354	
Hollow Shaft OHL (lbs)	2070	2070	2070	2070	2070	2070	2070	2070	
Solid Shaft OHL (lbs)	1640	1640	1640	1640	1640	1640	1640	1640	
Input HP	-	-	-	-	-	-	-	-	2B140
Output Torque (in•lbs)	-	-	-	-	-	-	-	-	
Hollow Shaft OHL (lbs)	-	-	-	-	-	-	-	-	
Solid Shaft OHL (lbs)	-	-	-	-	-	-	-	-	
Input HP	6.49	5.59	4.63	3.77	3.18	2.75	2.28	1.86	2B145
Output Torque (in•lbs)	18910	18844	18906	18844	18853	18870	18832	18789	
Hollow Shaft OHL (lbs)	2070	2070	2070	2070	2070	2070	2070	2070	
Solid Shaft OHL (lbs)	1640	1640	1640	1640	1640	1640	1640	1640	
Input HP	-	-	-	-	-	-	-	-	2B160
Output Torque (in•lbs)	-	-	-	-	-	-	-	-	
Hollow Shaft OHL (lbs)	-	-	-	-	-	-	-	-	
Solid Shaft OHL (lbs)	-	-	-	-	-	-	-	-	

Speed Reducers

Selection Tables

Frame Size Selection Tables 60 Hz, 1750 RPM

Single Reduction Y1, Y3, Y5, Y6 Mounting Positions

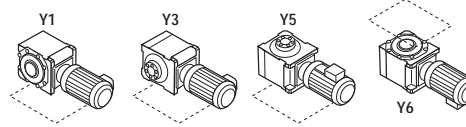

Dimensions on pages 2.22–2.23

Speed Reducers
Selection Tables

Output RPM	159	97.2	83.3	62.5	44.9	38.0	33.0	29.2	23.6	Frame Size
Ratio	11	18	21	28	39	46	53	60	74	
Input HP	29.4	29.5	24.8	-	-	-	-	-	-	2B165
Output Torque (in•lbs)	10721	17598	17263	-	-	-	-	-	-	
Hollow Shaft OHL (lbs)	2070	2070	2070	-	-	-	-	-	-	
Solid Shaft OHL (lbs)	1640	1640	1640	-	-	-	-	-	-	
Input HP	-	-	-	-	17.4	17.4	16.1	13.5	11.6	2C140
Output Torque (in•lbs)	-	-	-	-	22470	26550	28289	26807	28500	
Hollow Shaft OHL (lbs)	-	-	-	-	3480	3480	3480	3480	3480	
Solid Shaft OHL (lbs)	-	-	-	-	2850	2850	2850	2850	2850	
Input HP	-	-	-	20.2	20.2	20.2	19.6	16.1	14.8	2C145
Output Torque (in•lbs)	-	-	-	18740	26086	30823	34438	31970	36362	
Hollow Shaft OHL (lbs)	-	-	-	3480	3480	3480	3480	3480	3480	
Solid Shaft OHL (lbs)	-	-	-	2850	2850	2850	2850	2850	2850	
Input HP	-	-	27.2	26.4	26.4	-	-	17.6	-	2C160
Output Torque (in•lbs)	-	-	18933	24492	34092	-	-	34949	-	
Hollow Shaft OHL (lbs)	-	-	3480	3480	3480	-	-	3480	-	
Solid Shaft OHL (lbs)	-	-	2850	2850	2850	-	-	2850	-	
Input HP	-	-	32.3	32.3	29.5	24.9	21.6	19.1	15.4	2C165
Output Torque (in•lbs)	-	-	22483	29966	38096	37994	37953	37927	37836	
Hollow Shaft OHL (lbs)	-	-	3480	3480	3480	3480	3480	3480	3480	
Solid Shaft OHL (lbs)	-	-	2850	2850	2850	2850	2850	2850	2850	
Input HP	37.0	37.0	37.0	37.0	-	-	-	-	-	2C170
Output Torque (in•lbs)	13493	22072	25755	34326	-	-	-	-	-	
Hollow Shaft OHL (lbs)	3480	3480	3480	3480	-	-	-	-	-	
Solid Shaft OHL (lbs)	2850	2850	2850	2850	-	-	-	-	-	
Input HP	40.2	40.3	40.3	40.2	-	-	-	-	-	2C175
Output Torque (in•lbs)	14660	24040	28052	37295	-	-	-	-	-	
Hollow Shaft OHL (lbs)	3480	3480	3480	3480	-	-	-	-	-	
Solid Shaft OHL (lbs)	2850	2850	2850	2850	-	-	-	-	-	
Input HP	-	-	-	-	-	26.4	25.1	-	17.3	2D160
Output Torque (in•lbs)	-	-	-	-	-	40283	44102	-	42504	
Hollow Shaft OHL (lbs)	-	-	-	-	-	4810	4810	-	4810	
Solid Shaft OHL (lbs)	-	-	-	-	-	3930	3930	-	3930	
Input HP	-	-	-	-	32.3	30.3	30.1	25.2	21.6	2D165
Output Torque (in•lbs)	-	-	-	-	41712	46234	52888	50040	53069	
Hollow Shaft OHL (lbs)	-	-	-	-	4810	4810	4810	4810	4810	
Solid Shaft OHL (lbs)	-	-	-	-	3930	3930	3930	3930	3930	
Input HP	-	-	-	-	37.0	36.6	34.2	26.4	-	2D170
Output Torque (in•lbs)	-	-	-	-	47781	55847	60091	52423	-	
Hollow Shaft OHL (lbs)	-	-	-	-	4810	4810	4810	4810	-	
Solid Shaft OHL (lbs)	-	-	-	-	3930	3930	3930	3930	-	
Input HP	-	-	40.4	40.4	40.2	40.2	36.7	32.3	26.2	2D175
Output Torque (in•lbs)	-	-	28121	37480	51914	61340	64484	64139	64371	
Hollow Shaft OHL (lbs)	-	-	4810	4810	4810	4810	4810	4810	4810	
Solid Shaft OHL (lbs)	-	-	3930	3930	3930	3930	3930	3930	3930	
Input HP	-	-	-	-	-	-	-	-	-	2E170
Output Torque (in•lbs)	-	-	-	-	-	-	-	-	-	
Hollow Shaft OHL (lbs)	-	-	-	-	-	-	-	-	-	
Solid Shaft OHL (lbs)	-	-	-	-	-	-	-	-	-	
Input HP	-	-	-	-	40.4	40.4	40.2	32.3	29.5	2E175
Output Torque (in•lbs)	-	-	-	-	52172	61645	70634	64139	72479	
Hollow Shaft OHL (lbs)	-	-	-	-	5170	5170	5170	5170	5170	
Solid Shaft OHL (lbs)	-	-	-	-	4110	4110	4110	4110	4110	

60 Hz, 1750 RPM Frame Size Selection Tables

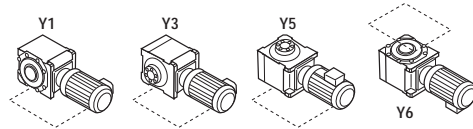

Single Reduction Y1, Y3, Y5, Y6 Mounting Positions

Dimensions on pages 2.22–2.23

Output RPM	19.9	17.2	14.2	11.6	9.8	8.45	7.03	5.74	Frame Size
Ratio	88	102	123	151	179	207	249	305	
Input HP	-	-	-	-	-	-	-	-	2B165
Output Torque (in•lbs)	-	-	-	-	-	-	-	-	
Hollow Shaft OHL (lbs)	-	-	-	-	-	-	-	-	
Solid Shaft OHL (lbs)	-	-	-	-	-	-	-	-	
Input HP	9.24	7.98	6.99	5.28	4.60	3.97	3.26	2.66	2C140
Output Torque (in•lbs)	26923	26901	28542	26392	27272	27242	26888	26870	
Hollow Shaft OHL (lbs)	3480	3480	3480	3480	3480	3480	3480	3480	
Solid Shaft OHL (lbs)	2850	2850	2850	2850	2850	2850	2850	2850	
Input HP	10.6	10.1	9.27	7.23	5.66	4.89	4.06	3.33	2C145
Output Torque (in•lbs)	30885	34048	37852	36139	33557	33555	33487	33638	
Hollow Shaft OHL (lbs)	3480	3480	3480	3480	3480	3480	3480	3480	
Solid Shaft OHL (lbs)	2850	2850	2850	2850	2850	2850	2850	2850	
Input HP	-	-	-	-	-	-	-	-	2C160
Output Torque (in•lbs)	-	-	-	-	-	-	-	-	
Hollow Shaft OHL (lbs)	-	-	-	-	-	-	-	-	
Solid Shaft OHL (lbs)	-	-	-	-	-	-	-	-	
Input HP	13.0	11.2	9.27	7.54	6.36	5.50	4.57	3.73	2C165
Output Torque (in•lbs)	37878	37756	37852	37689	37707	37740	37693	37679	
Hollow Shaft OHL (lbs)	3480	3480	3480	3480	3480	3480	3480	3480	
Solid Shaft OHL (lbs)	2850	2850	2850	2850	2850	2850	2850	2850	
Input HP	-	-	-	-	-	-	-	-	2C170
Output Torque (in•lbs)	-	-	-	-	-	-	-	-	
Hollow Shaft OHL (lbs)	-	-	-	-	-	-	-	-	
Solid Shaft OHL (lbs)	-	-	-	-	-	-	-	-	
Input HP	-	-	-	-	-	-	-	-	2C175
Output Torque (in•lbs)	-	-	-	-	-	-	-	-	
Hollow Shaft OHL (lbs)	-	-	-	-	-	-	-	-	
Solid Shaft OHL (lbs)	-	-	-	-	-	-	-	-	
Input HP	13.2	14.1	13.0	10.0	7.71	5.93	4.65	4.65	2D160
Output Torque (in•lbs)	38461	47533	53083	49985	45711	40691	38353	46972	
Hollow Shaft OHL (lbs)	4810	4810	4810	4810	4810	4810	4810	4810	
Solid Shaft OHL (lbs)	3930	3930	3930	3930	3930	3930	3930	3930	
Input HP	20.2	14.9	15.3	10.6	10.1	7.71	7.58	5.23	2D165
Output Torque (in•lbs)	58857	50229	62475	52984	59880	52905	62519	52831	
Hollow Shaft OHL (lbs)	4810	4810	4810	4810	4810	4810	4810	4810	
Solid Shaft OHL (lbs)	3930	3930	3930	3930	3930	3930	3930	3930	
Input HP	21.2	-	-	-	-	-	-	-	2D170
Output Torque (in•lbs)	61771	-	-	-	-	-	-	-	
Hollow Shaft OHL (lbs)	4810	-	-	-	-	-	-	-	
Solid Shaft OHL (lbs)	3930	-	-	-	-	-	-	-	
Input HP	22.0	19.0	15.7	12.8	10.8	9.33	7.75	6.32	2D175
Output Torque (in•lbs)	64102	64051	64108	63981	64030	64021	63922	63842	
Hollow Shaft OHL (lbs)	4810	4810	4810	4810	4810	4810	4810	4810	
Solid Shaft OHL (lbs)	3930	3930	3930	3930	3930	3930	3930	3930	
Input HP	-	19.2	16.1	13.1	11.3	9.59	7.94	6.45	2E170
Output Torque (in•lbs)	-	64725	65741	65481	66995	65806	65489	65155	
Hollow Shaft OHL (lbs)	-	5170	5170	5170	5170	5170	5170	5170	
Solid Shaft OHL (lbs)	-	4110	4110	4110	4110	4110	4110	4110	
Input HP	24.8	21.4	20.2	15.2	14.4	11.1	9.59	7.54	2E175
Output Torque (in•lbs)	72260	72142	82483	75978	85374	76167	79098	76166	
Hollow Shaft OHL (lbs)	5170	5170	5170	5170	5170	5170	5170	5170	
Solid Shaft OHL (lbs)	4110	4110	4110	4110	4110	4110	4110	4110	

Speed Reducers

Selection Tables

Frame Size Selection Tables 60 Hz, 1750 RPM

Single Reduction Y2, Y4 Mounting Positions

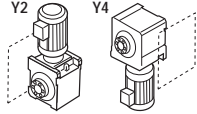

Dimensions on pages 2.22–2.23

Speed Reducers
Selection Tables

Output RPM	159	97.2	83.3	62.5	44.9	38.0	33.0	29.2	23.6	Frame Size
Ratio	11	18	21	28	39	46	53	60	74	
Input HP	3.15	3.15	3.15	3.15	3.15	3.15	3.15	2.67	2.59	2A100
Output Torque (in•lbs)	1149	1879	2193	2922	4068	4806	5535	5302	6363	
Hollow Shaft OHL (lbs)	1120	1120	1120	1120	1120	1120	1120	1120	1120	
Solid Shaft OHL (lbs)	990	990	990	990	990	990	990	990	990	
Input HP	4.26	4.26	4.26	4.26	4.26	4.26	4.26	3.30	3.14	2A105
Output Torque (in•lbs)	1554	2541	2965	3952	5501	6500	7485	6553	7715	
Hollow Shaft OHL (lbs)	1120	1120	1120	1120	1120	1120	1120	1120	1120	
Solid Shaft OHL (lbs)	990	990	990	990	990	990	990	990	990	
Input HP	-	-	4.76	4.76	4.76	4.76	4.76	4.26	3.65	2A110
Output Torque (in•lbs)	-	-	3313	4416	6147	7263	8364	8459	8968	
Hollow Shaft OHL (lbs)	-	-	1120	1120	1120	1120	1120	1120	1120	
Solid Shaft OHL (lbs)	-	-	990	990	990	990	990	990	990	
Input HP	-	-	5.26	5.26	5.26	5.23	5.23	4.79	3.88	2A115
Output Torque (in•lbs)	-	-	3661	4880	6793	7980	9189	9512	9533	
Hollow Shaft OHL (lbs)	-	-	1120	1120	1120	1120	1120	1120	1120	
Solid Shaft OHL (lbs)	-	-	990	990	990	990	990	990	990	
Input HP	6.80	6.80	6.80	6.80	6.80	-	-	-	-	2A120
Output Torque (in•lbs)	2480	4056	4733	6309	8781	-	-	-	-	
Hollow Shaft OHL (lbs)	1120	1120	1120	1120	1120	-	-	-	-	
Solid Shaft OHL (lbs)	990	990	990	990	990	-	-	-	-	
Input HP	7.79	7.79	7.79	9.32	7.40	6.26	5.43	-	-	2A125
Output Torque (in•lbs)	2841	4647	5422	8646	9556	9552	9541	-	-	
Hollow Shaft OHL (lbs)	1120	1120	1120	1120	1120	1120	1120	-	-	
Solid Shaft OHL (lbs)	990	990	990	990	990	990	990	-	-	
Input HP	12.7	12.7	-	-	-	-	-	-	-	2A140
Output Torque (in•lbs)	4631	7576	-	-	-	-	-	-	-	
Hollow Shaft OHL (lbs)	1120	1120	-	-	-	-	-	-	-	
Solid Shaft OHL (lbs)	990	990	-	-	-	-	-	-	-	
Input HP	14.8	14.8	12.3	10.1	-	-	-	-	-	2A145
Output Torque (in•lbs)	5397	8829	8562	9370	-	-	-	-	-	
Hollow Shaft OHL (lbs)	1120	1120	1120	1120	-	-	-	-	-	
Solid Shaft OHL (lbs)	990	990	990	990	-	-	-	-	-	
Input HP	-	-	-	-	-	6.80	6.80	6.80	5.31	2B120
Output Torque (in•lbs)	-	-	-	-	-	10376	11948	13503	13046	
Hollow Shaft OHL (lbs)	-	-	-	-	-	2070	2070	2070	2070	
Solid Shaft OHL (lbs)	-	-	-	-	-	1640	1640	1640	1640	
Input HP	-	-	-	-	7.94	7.94	7.94	7.59	6.54	2B125
Output Torque (in•lbs)	-	-	-	-	10254	12115	13951	15072	16068	
Hollow Shaft OHL (lbs)	-	-	-	-	2070	2070	2070	2070	2070	
Solid Shaft OHL (lbs)	-	-	-	-	1640	1640	1640	1640	1640	
Input HP	-	-	-	-	-	-	-	-	-	2B140
Output Torque (in•lbs)	-	-	-	-	-	-	-	-	-	
Hollow Shaft OHL (lbs)	-	-	-	-	-	-	-	-	-	
Solid Shaft OHL (lbs)	-	-	-	-	-	-	-	-	-	
Input HP	-	-	14.9	14.9	14.7	10.2	10.2	7.46	7.46	2B145
Output Torque (in•lbs)	-	-	10372	13823	18983	15564	17922	14813	18329	
Hollow Shaft OHL (lbs)	-	-	2070	2070	2070	2070	2070	2070	2070	
Solid Shaft OHL (lbs)	-	-	1640	1640	1640	1640	1640	1640	1640	
Input HP	16.9	16.9	-	-	-	-	-	-	-	2B160
Output Torque (in•lbs)	6163	10081	-	-	-	-	-	-	-	
Hollow Shaft OHL (lbs)	2070	2070	-	-	-	-	-	-	-	
Solid Shaft OHL (lbs)	1640	1640	-	-	-	-	-	-	-	

60 Hz, 1750 RPM Frame Size Selection Tables

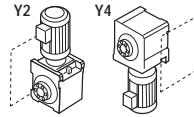

Single Reduction Y2, Y4 Mounting Positions

Dimensions on pages 2.22–2.23

Output RPM	19.9	17.2	14.2	11.6	9.8	8.45	7.03	5.74	Frame Size
Ratio	88	102	123	151	179	207	249	305	
Input HP	1.70	1.62	1.31	1.05	0.751	0.692	0.585	0.581	2A100
Output Torque (in•lbs)	4953	5461	5349	5248	4452	4748	4825	5866	
Hollow Shaft OHL (lbs)	1120	1120	1120	1120	1120	1120	1120	1120	
Solid Shaft OHL (lbs)	990	990	990	990	990	990	990	990	
Input HP	2.24	2.13	1.61	1.45	1.04	0.950	0.750	0.760	2A105
Output Torque (in•lbs)	6527	7180	6574	7248	6166	6519	6186	7673	
Hollow Shaft OHL (lbs)	1120	1120	1120	1120	1120	1120	1120	1120	
Solid Shaft OHL (lbs)	990	990	990	990	990	990	990	990	
Input HP	2.56	2.55	2.01	1.74	1.27	1.15	0.900	0.890	2A110
Output Torque (in•lbs)	7459	8596	8207	8697	7529	7891	7423	8986	
Hollow Shaft OHL (lbs)	1120	1120	1120	1120	1120	1120	1120	1120	
Solid Shaft OHL (lbs)	990	990	990	990	990	990	990	990	
Input HP	2.98	2.81	2.33	1.89	1.49	1.35	1.02	0.940	2A115
Output Torque (in•lbs)	8683	9473	9514	9447	8834	9264	8413	9491	
Hollow Shaft OHL (lbs)	1120	1120	1120	1120	1120	1120	1120	1120	
Solid Shaft OHL (lbs)	990	990	990	990	990	990	990	990	
Input HP	-	-	-	-	-	-	-	-	2A120
Output Torque (in•lbs)	-	-	-	-	-	-	-	-	
Hollow Shaft OHL (lbs)	-	-	-	-	-	-	-	-	
Solid Shaft OHL (lbs)	-	-	-	-	-	-	-	-	
Input HP	3.26	-	-	-	1.60	1.38	1.15	-	2A125
Output Torque (in•lbs)	9499	-	-	-	9486	9469	9485	-	
Hollow Shaft OHL (lbs)	1120	-	-	-	1120	1120	1120	-	
Solid Shaft OHL (lbs)	990	-	-	-	990	990	990	-	
Input HP	-	-	-	-	-	-	-	-	2A140
Output Torque (in•lbs)	-	-	-	-	-	-	-	-	
Hollow Shaft OHL (lbs)	-	-	-	-	-	-	-	-	
Solid Shaft OHL (lbs)	-	-	-	-	-	-	-	-	
Input HP	-	-	-	-	-	-	-	-	2A145
Output Torque (in•lbs)	-	-	-	-	-	-	-	-	
Hollow Shaft OHL (lbs)	-	-	-	-	-	-	-	-	
Solid Shaft OHL (lbs)	-	-	-	-	-	-	-	-	
Input HP	4.14	4.01	3.34	2.56	2.31	1.74	1.28	1.27	2B120
Output Torque (in•lbs)	12063	13518	13638	12796	13695	11940	10557	12822	
Hollow Shaft OHL (lbs)	2070	2070	2070	2070	2070	2070	2070	2070	
Solid Shaft OHL (lbs)	1640	1640	1640	1640	1640	1640	1640	1640	
Input HP	5.31	5.06	4.26	3.19	3.06	2.17	1.61	1.52	2B125
Output Torque (in•lbs)	15472	17058	17395	15945	18142	14890	13279	15346	
Hollow Shaft OHL (lbs)	2070	2070	2070	2070	2070	2070	2070	2070	
Solid Shaft OHL (lbs)	1640	1640	1640	1640	1640	1640	1640	1640	
Input HP	-	-	-	-	-	-	-	-	2B140
Output Torque (in•lbs)	-	-	-	-	-	-	-	-	
Hollow Shaft OHL (lbs)	-	-	-	-	-	-	-	-	
Solid Shaft OHL (lbs)	-	-	-	-	-	-	-	-	
Input HP	6.49	-	4.63	-	-	2.75	2.04	1.86	2B145
Output Torque (in•lbs)	18910	-	18910	-	-	18870	16826	18779	
Hollow Shaft OHL (lbs)	2070	-	2070	-	-	2070	2070	2070	
Solid Shaft OHL (lbs)	1640	-	1640	-	-	1640	1640	1640	
Input HP	-	-	-	-	-	-	-	-	2B160
Output Torque (in•lbs)	-	-	-	-	-	-	-	-	
Hollow Shaft OHL (lbs)	-	-	-	-	-	-	-	-	
Solid Shaft OHL (lbs)	-	-	-	-	-	-	-	-	

Speed Reducers

Selection Tables

Frame Size Selection Tables 60 Hz, 1750 RPM

Single Reduction Y2, Y4 Mounting Positions

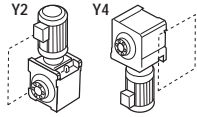

Dimensions on pages 2.22–2.23

Speed Reducers
Selection Tables

Output RPM	159	97.2	83.3	62.5	44.9	38.0	33.0	29.2	23.6	Frame Size
Ratio	11	18	21	28	39	46	53	60	74	
Input HP	20.1	20.1	-	20.1	-	12.5	10.8	9.54	7.72	2B165
Output Torque (in•lbs)	7330	11990	-	18647	-	19073	18976	18944	18967	
Hollow Shaft OHL (lbs)	2070	2070	-	2070	-	2070	2070	2070	2070	
Solid Shaft OHL (lbs)	1640	1640	-	1640	-	1640	1640	1640	1640	
Input HP	-	-	-	-	-	-	-	-	-	2C140
Output Torque (in•lbs)	-	-	-	-	-	-	-	-	-	
Hollow Shaft OHL (lbs)	-	-	-	-	-	-	-	-	-	
Solid Shaft OHL (lbs)	-	-	-	-	-	-	-	-	-	
Input HP	-	-	14.9	-	14.9	-	-	-	-	2C145
Output Torque (in•lbs)	-	-	10372	-	19242	-	-	-	-	
Hollow Shaft OHL (lbs)	-	-	3480	-	3480	-	-	-	-	
Solid Shaft OHL (lbs)	-	-	2850	-	2850	-	-	-	-	
Input HP	-	-	-	-	-	-	-	-	-	2C160
Output Torque (in•lbs)	-	-	-	-	-	-	-	-	-	
Hollow Shaft OHL (lbs)	-	-	-	-	-	-	-	-	-	
Solid Shaft OHL (lbs)	-	-	-	-	-	-	-	-	-	
Input HP	-	-	-	20.4	20.4	14.9	14.9	14.9	10.2	2C165
Output Torque (in•lbs)	-	-	-	18926	26344	22735	26180	29587	25060	
Hollow Shaft OHL (lbs)	-	-	-	3480	3480	3480	3480	3480	3480	
Solid Shaft OHL (lbs)	-	-	-	2850	2850	2850	2850	2850	2850	
Input HP	27.1	27.1	-	-	-	-	-	-	-	2C170
Output Torque (in•lbs)	9883	16166	-	-	-	-	-	-	-	
Hollow Shaft OHL (lbs)	3480	3480	-	-	-	-	-	-	-	
Solid Shaft OHL (lbs)	2850	2850	-	-	-	-	-	-	-	
Input HP	29.5	29.5	-	-	-	24.9	16.1	-	13.0	2C175
Output Torque (in•lbs)	10758	17598	-	-	-	37994	28289	-	31940	
Hollow Shaft OHL (lbs)	3480	3480	-	-	-	3480	3480	-	3480	
Solid Shaft OHL (lbs)	2850	2850	-	-	-	2850	2850	-	2850	
Input HP	-	-	-	-	-	-	-	-	-	2D160
Output Torque (in•lbs)	-	-	-	-	-	-	-	-	-	
Hollow Shaft OHL (lbs)	-	-	-	-	-	-	-	-	-	
Solid Shaft OHL (lbs)	-	-	-	-	-	-	-	-	-	
Input HP	-	-	-	-	-	-	-	-	-	2D165
Output Torque (in•lbs)	-	-	-	-	-	-	-	-	-	
Hollow Shaft OHL (lbs)	-	-	-	-	-	-	-	-	-	
Solid Shaft OHL (lbs)	-	-	-	-	-	-	-	-	-	
Input HP	-	-	-	-	-	-	-	-	-	2D170
Output Torque (in•lbs)	-	-	-	-	-	-	-	-	-	
Hollow Shaft OHL (lbs)	-	-	-	-	-	-	-	-	-	
Solid Shaft OHL (lbs)	-	-	-	-	-	-	-	-	-	
Input HP	-	-	-	-	-	-	-	-	-	2D175
Output Torque (in•lbs)	-	-	-	-	-	-	-	-	-	
Hollow Shaft OHL (lbs)	-	-	-	-	-	-	-	-	-	
Solid Shaft OHL (lbs)	-	-	-	-	-	-	-	-	-	
Input HP	-	-	-	-	-	-	-	-	-	2E170
Output Torque (in•lbs)	-	-	-	-	-	-	-	-	-	
Hollow Shaft OHL (lbs)	-	-	-	-	-	-	-	-	-	
Solid Shaft OHL (lbs)	-	-	-	-	-	-	-	-	-	
Input HP	-	-	-	-	-	-	-	-	-	2E175
Output Torque (in•lbs)	-	-	-	-	-	-	-	-	-	
Hollow Shaft OHL (lbs)	-	-	-	-	-	-	-	-	-	
Solid Shaft OHL (lbs)	-	-	-	-	-	-	-	-	-	

60 Hz, 1750 RPM Frame Size Selection Tables

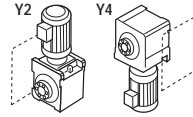
Single Reduction
Y2, Y4 Mounting Positions

Dimensions on pages 2.22–2.23

Output RPM	19.9	17.2	14.2	11.6	9.8	8.45	7.03	5.74	Frame Size
Ratio	88	102	123	151	179	207	249	305	
Input HP	-	5.59	-	3.77	3.18	-	2.28	-	2B165
Output Torque (in•lbs)	-	18844	-	18844	18853	-	18805	-	
Hollow Shaft OHL (lbs)	-	2070	-	2070	2070	-	2070	-	
Solid Shaft OHL (lbs)	-	1640	-	1640	1640	-	1640	-	
Input HP	-	-	-	-	-	-	-	-	2C140
Output Torque (in•lbs)	-	-	-	-	-	-	-	-	
Hollow Shaft OHL (lbs)	-	-	-	-	-	-	-	-	
Solid Shaft OHL (lbs)	-	-	-	-	-	-	-	-	
Input HP	7.46	-	5.02	-	-	2.98	-	2.04	2C145
Output Torque (in•lbs)	21736	-	20498	-	-	20448	-	20607	
Hollow Shaft OHL (lbs)	3480	-	3480	-	-	3480	-	3480	
Solid Shaft OHL (lbs)	2850	-	2850	-	-	2850	-	2850	
Input HP	-	-	-	-	-	-	-	-	2C160
Output Torque (in•lbs)	-	-	-	-	-	-	-	-	
Hollow Shaft OHL (lbs)	-	-	-	-	-	-	-	-	
Solid Shaft OHL (lbs)	-	-	-	-	-	-	-	-	
Input HP	10.2	10.2	9.27	5.02	5.02	5.02	2.98	2.98	2C165
Output Torque (in•lbs)	29720	34385	37852	25093	29762	34447	24579	30103	
Hollow Shaft OHL (lbs)	3480	3480	3480	3480	3480	3480	3480	3480	
Solid Shaft OHL (lbs)	2850	2850	2850	2850	2850	2850	2850	2850	
Input HP	-	-	-	-	-	-	-	-	2C170
Output Torque (in•lbs)	-	-	-	-	-	-	-	-	
Hollow Shaft OHL (lbs)	-	-	-	-	-	-	-	-	
Solid Shaft OHL (lbs)	-	-	-	-	-	-	-	-	
Input HP	13.0	11.2	-	7.54	6.36	5.50	4.57	3.73	2C175
Output Torque (in•lbs)	37878	37756	-	37689	37707	37740	37693	37679	
Hollow Shaft OHL (lbs)	3480	3480	-	3480	3480	3480	3480	3480	
Solid Shaft OHL (lbs)	2850	2850	-	2850	2850	2850	2850	2850	
Input HP	-	-	-	-	-	-	-	-	2D160
Output Torque (in•lbs)	-	-	-	-	-	-	-	-	
Hollow Shaft OHL (lbs)	-	-	-	-	-	-	-	-	
Solid Shaft OHL (lbs)	-	-	-	-	-	-	-	-	
Input HP	-	-	10.2	-	-	-	-	-	2D165
Output Torque (in•lbs)	-	-	41650	-	-	-	-	-	
Hollow Shaft OHL (lbs)	-	-	4810	-	-	-	-	-	
Solid Shaft OHL (lbs)	-	-	3930	-	-	-	-	-	
Input HP	-	-	-	-	-	-	-	-	2D170
Output Torque (in•lbs)	-	-	-	-	-	-	-	-	
Hollow Shaft OHL (lbs)	-	-	-	-	-	-	-	-	
Solid Shaft OHL (lbs)	-	-	-	-	-	-	-	-	
Input HP	14.9	14.9	-	10.2	7.46	7.46	5.02	5.02	2D175
Output Torque (in•lbs)	43414	50229	-	50985	44228	51190	41405	50710	
Hollow Shaft OHL (lbs)	4810	4810	-	4810	4810	4810	4810	4810	
Solid Shaft OHL (lbs)	3930	3930	-	3930	3930	3930	3930	3930	
Input HP	-	-	-	-	-	-	-	-	2E170
Output Torque (in•lbs)	-	-	-	-	-	-	-	-	
Hollow Shaft OHL (lbs)	-	-	-	-	-	-	-	-	
Solid Shaft OHL (lbs)	-	-	-	-	-	-	-	-	
Input HP	14.9	14.9	10.2	10.2	7.46	7.46	5.02	5.02	2E175
Output Torque (in•lbs)	43414	50229	41650	50985	44228	51190	41405	50710	
Hollow Shaft OHL (lbs)	5170	5170	5170	5170	5170	5170	5170	5170	
Solid Shaft OHL (lbs)	4110	4110	4110	4110	4110	4110	4110	4110	

Speed
ReducersSelection
Tables

Frame Size Selection Tables 60 Hz, 1750 RPM

Double Reduction Y1, Y2, Y3, Y4, Y5, Y6 Mounting Positions

Dimensions on pages 2.24–2.25

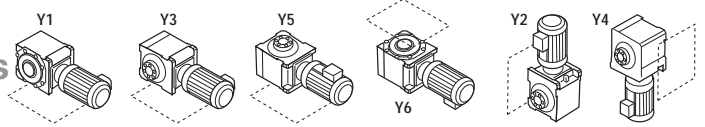

Speed Reducers
Selection Tables

Output RPM	4.81	4.13	3.50	3.03	2.56	2.16	1.83	1.57	1.33	1.06	0.894	0.770	0.684	Frame Size
Ratio	364	424	501	578	683	809	956	1117	1320	1656	1957	2272	2559	
Input HP	0.576	0.576	0.573	0.496	0.420	0.355	0.300	0.257	0.217	0.173	0.147	0.134	0.134	2A10DA
Output Torque (in•lbs)	6603	7682	9028	9028	9028	9028	9028	9028	9028	9028	9028	8939	9028	
Hollow Shaft OHL (lbs)	1120	1120	1120	1120	1120	1120	1120	1120	1120	1120	1120	1120	1120	
Solid Shaft OHL (lbs)	990	990	990	990	990	990	990	990	990	990	990	990	990	
Input HP	-	-	0.576	0.576	0.531	0.448	0.379	0.324	0.275	0.219	0.185	0.159	0.142	2A12DA
Output Torque (in•lbs)	-	-	9116	10444	11417	11417	11417	11417	11417	11417	11417	11417	11417	
Hollow Shaft OHL (lbs)	-	-	1120	1120	1120	1120	1120	1120	1120	1120	1120	1120	1120	
Solid Shaft OHL (lbs)	-	-	990	990	990	990	990	990	990	990	990	990	990	
Input HP	0.995	0.855	0.724	0.627	-	-	-	-	-	-	-	-	-	2A12DB
Output Torque (in•lbs)	11417	11417	11417	11417	-	-	-	-	-	-	-	-	-	
Hollow Shaft OHL (lbs)	1120	1120	1120	1120	-	-	-	-	-	-	-	-	-	
Solid Shaft OHL (lbs)	990	990	990	990	-	-	-	-	-	-	-	-	-	
Input HP	-	-	-	-	0.576	0.576	0.576	0.539	0.456	0.364	0.308	0.265	0.235	2B12DA
Output Torque (in•lbs)	-	-	-	-	12391	14692	17347	18940	18940	18940	18940	18940	18940	
Hollow Shaft OHL (lbs)	-	-	-	-	2060	2060	2060	2060	2060	2060	2060	2060	2060	
Solid Shaft OHL (lbs)	-	-	-	-	1640	1640	1640	1640	1640	1640	1640	1640	1640	
Input HP	1.65	1.40	1.20	1.04	0.88	0.74	0.63	-	-	-	-	-	-	2B12DB
Output Torque (in•lbs)	18940	18763	18940	18940	18940	18940	18940	-	-	-	-	-	-	
Hollow Shaft OHL (lbs)	2060	2060	2060	2060	2060	2060	2060	-	-	-	-	-	-	
Solid Shaft OHL (lbs)	1640	1640	1640	1640	1640	1640	1640	-	-	-	-	-	-	
Input HP	-	-	-	-	-	-	-	0.576	0.547	0.436	0.369	0.318	0.282	2B14DA
Output Torque (in•lbs)	-	-	-	-	-	-	-	20268	22746	22746	22746	22746	22746	
Hollow Shaft OHL (lbs)	-	-	-	-	-	-	-	2060	2060	2060	2060	2060	2060	
Solid Shaft OHL (lbs)	-	-	-	-	-	-	-	1640	1640	1640	1640	1640	1640	
Input HP	1.983	1.704	1.442	1.250	1.058	0.893	0.755	0.646	-	-	-	-	-	2B14DB
Output Torque (in•lbs)	22746	22746	22746	22746	22746	22746	22746	22746	-	-	-	-	-	
Hollow Shaft OHL (lbs)	2060	2060	2060	2060	2060	2060	2060	2060	-	-	-	-	-	
Solid Shaft OHL (lbs)	1640	1640	1640	1640	1640	1640	1640	1640	-	-	-	-	-	

NOTE: Motor HP in **GRAY** is to overcome breakaway torque requirements in cold temperatures or high inertia applications. A torque limiting device is recommended to protect the unit or driven machine.

60 Hz, 1750 RPM Frame Size Selection Tables

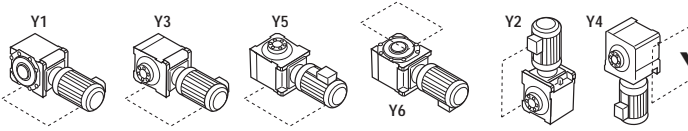

Double Reduction Y1, Y2, Y3, Y4, Y5, Y6 Mounting Positions

Dimensions on pages 2.24–2.25

Output RPM	0.595	0.499	0.401	0.338	0.270	0.242	0.197	0.164	0.144	0.113	0.0974	0.0809	0.0661	Frame Size
Ratio	2944	3511	4365	5177	6472	7228	8880	10658	12184	15530	17966	21620	26492	
Input HP	0.134	0.134	0.134	0.134	0.134	0.134	0.134	0.134	0.134	0.134	0.134	-	-	2A10DA
Output Torque (in•lbs)	9028	8939	9028	9028	9028	8939	8939	9028	8939	9028	9028	-	-	
Hollow Shaft OHL (lbs)	1120	120	1120	1120	1120	1120	1120	1120	1120	1120	1120	-	-	
Solid Shaft OHL (lbs)	990	990	990	990	990	990	990	990	990	990	-	-		
Input HP	0.134	0.134	0.134	0.134	0.134	0.134	0.134	0.134	0.134	0.134	0.134	-	-	2A12DA
Output Torque (in•lbs)	11417	11417	11417	11417	11417	11417	11417	11417	11417	11417	11417	-	-	
Hollow Shaft OHL (lbs)	1120	1120	1120	1120	1120	1120	1120	1120	1120	1120	1120	-	-	
Solid Shaft OHL (lbs)	990	990	990	990	990	990	990	990	990	990	990	-	-	
Input HP	-	-	-	-	-	-	-	-	-	-	-	0.134	0.134	2A12DB
Output Torque (in•lbs)	-	-	-	-	-	-	-	-	-	-	-	11417	11417	
Hollow Shaft OHL (lbs)	-	-	-	-	-	-	-	-	-	-	-	1120	1120	
Solid Shaft OHL (lbs)	-	-	-	-	-	-	-	-	-	-	-	990	990	
Input HP	0.205	0.171	0.138	0.134	0.134	0.134	0.134	0.134	0.134	0.134	0.134	-	-	2B12DA
Output Torque (in•lbs)	18940	18940	18940	18940	18940	18940	18940	18940	18940	18940	18940	-	-	
Hollow Shaft OHL (lbs)	2060	2060	2060	2060	2060	2060	2060	2060	2060	2060	2060	-	-	
Solid Shaft OHL (lbs)	1640	1640	1640	1640	1640	1640	1640	1640	1640	1640	1640	-	-	
Input HP	-	-	-	-	-	-	-	-	-	-	-	0.138	0.134	2B12DB
Output Torque (in•lbs)	-	-	-	-	-	-	-	-	-	-	-	18940	18940	
Hollow Shaft OHL (lbs)	-	-	-	-	-	-	-	-	-	-	-	2060	2060	
Solid Shaft OHL (lbs)	-	-	-	-	-	-	-	-	-	-	-	1640	1640	
Input HP	0.268	0.268	0.268	0.268	0.268	0.268	0.268	0.268	0.268	0.268	0.268	-	-	2B14DA
Output Torque (in•lbs)	22746	22746	22746	22746	22746	22746	22746	22746	22746	22746	22746	-	-	
Hollow Shaft OHL (lbs)	2060	2060	2060	2060	2060	2060	2060	2060	2060	2060	2060	-	-	
Solid Shaft OHL (lbs)	1640	1640	1640	1640	1640	1640	1640	1640	1640	1640	1640	-	-	
Input HP	-	-	-	-	-	-	-	-	-	-	-	0.268	0.268	2B14DB
Output Torque (in•lbs)	-	-	-	-	-	-	-	-	-	-	-	22746	22746	
Hollow Shaft OHL (lbs)	-	-	-	-	-	-	-	-	-	-	-	2060	2060	
Solid Shaft OHL (lbs)	-	-	-	-	-	-	-	-	-	-	-	1640	1640	

Speed Reducers
Selection Tables

NOTE: Motor HP in **GRAY** is to overcome breakaway torque requirements in cold temperatures or high inertia applications. A torque limiting device is recommended to protect the unit or driven machine.

Frame Size Selection Tables 60 Hz, 1750 RPM

Double Reduction Y1, Y2, Y3, Y4, Y5, Y6 Mounting Positions

Dimensions on pages 2.24–2.25

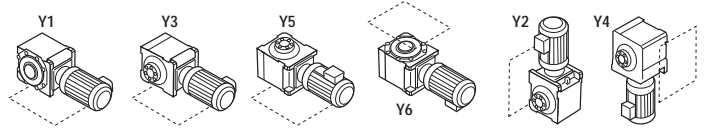

Speed Reducers
Selection Tables

Output RPM	4.81	4.13	3.50	3.03	2.56	2.16	1.83	1.57	1.33	1.06	0.894	0.770	0.684	Frame Size
Ratio	364	424	501	578	683	809	956	1117	1320	1656	1957	2272	2559	
Input HP	-	-	-	-	-	-	-	-	0.576	0.576	0.576	0.576	0.512	2C14DA
Output Torque (in•lbs)	-	-	-	-	-	-	-	-	23985	30004	35491	41244	41244	
Hollow Shaft OHL (lbs)	-	-	-	-	-	-	-	-	3480	3480	3480	3480	3480	
Solid Shaft OHL (lbs)	-	-	-	-	-	-	-	-	2850	2850	2850	2850	2850	
Input HP	2.14	2.14	2.14	2.14	1.90	1.58	1.34	1.17	0.992	0.791	0.669	-	-	2C14DB
Output Torque (in•lbs)	24605	28588	33810	39032	40890	40271	40271	41244	41244	41244	41244	-	-	
Hollow Shaft OHL (lbs)	3480	3480	3480	3480	3480	3480	3480	3480	3480	3480	3480	-	-	
Solid Shaft OHL (lbs)	2850	2850	2850	2850	2850	2850	2850	2850	2850	2850	2850	-	-	
Input HP	3.60	2.92	2.62	2.25	-	-	-	-	-	-	-	-	-	2C14DC
Output Torque (in•lbs)	41244	38943	41244	40890	-	-	-	-	-	-	-	-	-	
Hollow Shaft OHL (lbs)	3480	3480	3480	3480	-	-	-	-	-	-	-	-	-	
Solid Shaft OHL (lbs)	2850	2850	2850	2850	-	-	-	-	-	-	-	-	-	
Input HP	-	-	-	-	2.12	1.79	1.51	1.29	1.09	0.872	0.738	0.635	0.564	2C16DA
Output Torque (in•lbs)	-	-	-	-	45493	45493	45493	45493	45493	45493	45493	45493	45493	
Hollow Shaft OHL (lbs)	-	-	-	-	3480	3480	3480	3480	3480	3480	3480	3480	3480	
Solid Shaft OHL (lbs)	-	-	-	-	2850	2850	2850	2850	2850	2850	2850	2850	2850	
Input HP	3.97	3.41	2.88	2.50	-	-	-	-	-	-	-	-	-	2C16DB
Output Torque (in•lbs)	45493	45493	45493	45493	-	-	-	-	-	-	-	-	-	
Hollow Shaft OHL (lbs)	3480	3480	3480	3480	-	-	-	-	-	-	-	-	-	
Solid Shaft OHL (lbs)	2850	2850	2850	2850	-	-	-	-	-	-	-	-	-	
Input HP	-	-	-	-	2.14	2.14	2.10	1.80	1.52	1.21	1.03	0.883	0.784	2D16DA
Output Torque (in•lbs)	-	-	-	-	46112	54609	63283	63283	63283	63283	63283	63283	63283	
Hollow Shaft OHL (lbs)	-	-	-	-	4810	4810	4810	4810	4810	4810	4810	4810	4810	
Solid Shaft OHL (lbs)	-	-	-	-	3930	3930	3930	3930	3930	3930	3930	3930	3930	
Input HP	4.50	4.50	4.01	3.48	2.94	2.48	-	-	-	-	-	-	-	2D16DB
Output Torque (in•lbs)	51600	60096	63283	63283	63283	63283	-	-	-	-	-	-	-	
Hollow Shaft OHL (lbs)	4810	4810	4810	4810	4810	4810	-	-	-	-	-	-	-	
Solid Shaft OHL (lbs)	3930	3930	3930	3930	3930	3930	-	-	-	-	-	-	-	

NOTE: Motor HP in **GRAY** is to overcome breakaway torque requirements in cold temperatures or high inertia applications. A torque limiting device is recommended to protect the unit or driven machine.

60 Hz, 1750 RPM Frame Size Selection Tables

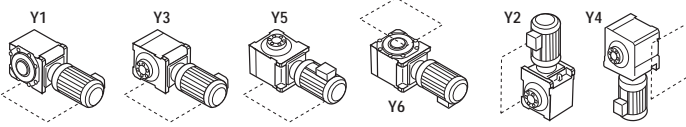

Double Reduction Y1, Y2, Y3, Y4, Y5, Y6 Mounting Positions

Dimensions on pages 2.24–2.25

Output RPM	0.595	0.499	0.401	0.338	0.270	0.242	0.197	0.164	0.144	0.113	0.0974	0.0809	0.0661	Frame Size
Ratio	2944	3511	4365	5177	6472	7228	8880	10658	12184	15530	17966	21620	26492	
Input HP	0.405	0.373	0.300	0.268	0.268	0.268	0.268	0.268	0.268	0.268	0.268	-	-	2C14DA
Output Torque (in•lbs)	37615	41244	41244	37615	41244	41244	41244	37615	41244	37615	37615	-	-	
Hollow Shaft OHL (lbs)	3480	3480	3480	3480	3480	3480	3480	3480	3480	3480	3480	-	-	
Solid Shaft OHL (lbs)	2850	2850	2850	2850	2850	2850	2850	2850	2850	2850	2850	-	-	
Input HP	0.445	0.445	-	-	-	-	-	-	-	-	-	0.268	0.268	2C14DB
Output Torque (in•lbs)	41244	41244	-	-	-	-	-	-	-	-	-	37615	37615	
Hollow Shaft OHL (lbs)	3480	3480	-	-	-	-	-	-	-	-	-	3480	3480	
Solid Shaft OHL (lbs)	2850	2850	-	-	-	-	-	-	-	-	-	2850	2850	
Input HP	-	-	-	-	-	-	-	-	-	-	-	-	-	2C14DC
Output Torque (in•lbs)	-	-	-	-	-	-	-	-	-	-	-	-	-	
Hollow Shaft OHL (lbs)	-	-	-	-	-	-	-	-	-	-	-	-	-	
Solid Shaft OHL (lbs)	-	-	-	-	-	-	-	-	-	-	-	-	-	
Input HP	0.536	0.536	0.536	0.536	0.536	0.536	0.268	0.268	0.268	0.268	0.268	0.268	0.268	2C16DA
Output Torque (in•lbs)	45493	45493	45493	45493	45493	45493	45493	45493	45493	45493	45493	45493	45493	
Hollow Shaft OHL (lbs)	3480	3480	3480	3480	3480	3480	3480	3480	3480	3480	3480	3480	3480	
Solid Shaft OHL (lbs)	2850	2850	2850	2850	2850	2850	2850	2850	2850	2850	2850	2850	2850	
Input HP	-	-	-	-	-	-	-	0.268	-	-	-	-	-	2C16DB
Output Torque (in•lbs)	-	-	-	-	-	-	-	45493	-	-	-	-	-	
Hollow Shaft OHL (lbs)	-	-	-	-	-	-	-	3480	-	-	-	-	-	
Solid Shaft OHL (lbs)	-	-	-	-	-	-	-	2850	-	-	-	-	-	
Input HP	0.682	0.572	0.536	0.536	0.536	0.536	0.268	0.268	0.268	0.268	0.268	0.268	0.268	2D16DA
Output Torque (in•lbs)	63283	63283	63283	61778	63283	63283	63283	61778	63283	61778	61778	61778	61778	
Hollow Shaft OHL (lbs)	4810	4810	4810	4810	4810	4810	4810	4810	4810	4810	4810	4810	4810	
Solid Shaft OHL (lbs)	3930	3930	3930	3930	3930	3930	3930	3930	3930	3930	3930	3930	3930	
Input HP	-	-	-	-	-	-	-	-	-	-	-	-	-	2D16DB
Output Torque (in•lbs)	-	-	-	-	-	-	-	-	-	-	-	-	-	
Hollow Shaft OHL (lbs)	-	-	-	-	-	-	-	-	-	-	-	-	-	
Solid Shaft OHL (lbs)	-	-	-	-	-	-	-	-	-	-	-	-	-	

Speed Reducers

Selection Tables

NOTE: Motor HP in **GRAY** is to overcome breakaway torque requirements in cold temperatures or high inertia applications. A torque limiting device is recommended to protect the unit or driven machine.

Frame Size Selection Tables 60 Hz, 1750 RPM

Double Reduction Y1, Y2, Y3, Y4, Y5, Y6 Mounting Positions

Dimensions on pages 2.24–2.25

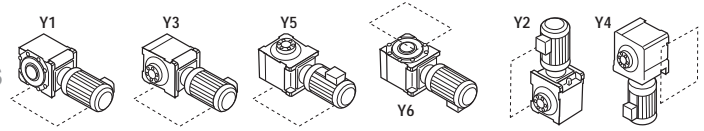

Speed Reducers
Selection Tables

Output RPM	4.81	4.13	3.50	3.03	2.56	2.16	1.83	1.57	1.33	1.06	0.894	0.770	0.684	Frame Size
Ratio	364	424	501	578	683	809	956	1117	1320	1656	1957	2272	2559	
Input HP	5.51	4.74	-	-	-	-	-	-	-	-	-	-	-	2D16DC
Output Torque (in•lbs)	63283	63283	-	-	-	-	-	-	-	-	-	-	-	
Hollow Shaft OHL (lbs)	4810	4810	-	-	-	-	-	-	-	-	-	-	-	
Solid Shaft OHL (lbs)	3930	3930	-	-	-	-	-	-	-	-	-	-	-	
Input HP	-	-	-	-	-	-	2.14	2.14	1.86	1.48	1.25	1.08	0.957	2D17DA
Output Torque (in•lbs)	-	-	-	-	-	-	64610	75496	77178	77178	77178	77178	77178	
Hollow Shaft OHL (lbs)	-	-	-	-	-	-	4810	4810	4810	4810	4810	4810	4810	
Solid Shaft OHL (lbs)	-	-	-	-	-	-	3930	3930	3930	3930	3930	3930	3930	
Input HP	-	-	4.50	4.24	3.59	3.03	2.56	2.19	-	-	-	-	-	2D17DB
Output Torque (in•lbs)	-	-	70983	77178	77178	77178	77178	77178	-	-	-	-	-	
Hollow Shaft OHL (lbs)	-	-	4810	4810	4810	4810	4810	4810	-	-	-	-	-	
Solid Shaft OHL (lbs)	-	-	3930	3930	3930	3930	3930	3930	-	-	-	-	-	
Input HP	6.73	5.78	-	-	-	-	-	-	-	-	-	-	-	2D17DC
Output Torque (in•lbs)	77178	77178	-	-	-	-	-	-	-	-	-	-	-	
Hollow Shaft OHL (lbs)	4810	4810	-	-	-	-	-	-	-	-	-	-	-	
Solid Shaft OHL (lbs)	3930	3930	-	-	-	-	-	-	-	-	-	-	-	
Input HP	-	-	-	-	-	-	-	-	2.14	1.82	1.54	1.33	1.18	2E17DA
Output Torque (in•lbs)	-	-	-	-	-	-	-	-	89392	94702	94702	94702	94702	
Hollow Shaft OHL (lbs)	-	-	-	-	-	-	-	-	5170	5170	5170	5170	5170	
Solid Shaft OHL (lbs)	-	-	-	-	-	-	-	-	4110	4110	4110	4110	4110	
Input HP	-	-	-	4.50	4.41	3.72	3.15	2.70	2.28	-	-	-	-	2E17DB
Output Torque (in•lbs)	-	-	-	81957	94702	94702	94702	94702	94702	-	-	-	-	
Hollow Shaft OHL (lbs)	-	-	-	5170	5170	5170	5170	5170	5170	-	-	-	-	
Solid Shaft OHL (lbs)	-	-	-	4110	4110	4110	4110	4110	4110	-	-	-	-	
Input HP	8.27	7.11	6.01	5.21	-	-	-	-	-	-	-	-	-	2E17DC
Output Torque (in•lbs)	94702	94702	94702	94702	-	-	-	-	-	-	-	-	-	
Hollow Shaft OHL (lbs)	5170	5170	5170	5170	-	-	-	-	-	-	-	-	-	
Solid Shaft OHL (lbs)	4110	4110	4110	4110	-	-	-	-	-	-	-	-	-	

NOTE: Motor HP in **GRAY** is to overcome breakaway torque requirements in cold temperatures or high inertia applications. A torque limiting device is recommended to protect the unit or driven machine.

60 Hz, 1750 RPM Frame Size Selection Tables

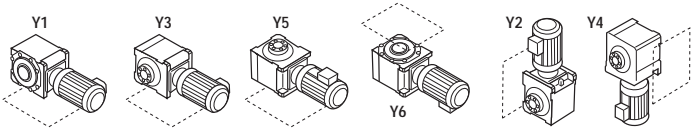

Double Reduction Y1, Y2, Y3, Y4, Y5, Y6 Mounting Positions

Dimensions on pages 2.24–2.25

Output RPM	0.595	0.499	0.401	0.338	0.270	0.242	0.197	0.164	0.144	0.113	0.0974	0.0809	0.0661	Frame Size
Ratio	2944	3511	4365	5177	6472	7228	8880	10658	12184	15530	17966	21620	26492	
Input HP	-	-	-	-	-	-	-	-	-	-	-	-	-	2D16DC
Output Torque (in•lbs)	-	-	-	-	-	-	-	-	-	-	-	-	-	
Hollow Shaft OHL (lbs)	-	-	-	-	-	-	-	-	-	-	-	-	-	
Solid Shaft OHL (lbs)	-	-	-	-	-	-	-	-	-	-	-	-	-	
Input HP	0.832	0.698	0.561	-	-	-	-	0.536	0.268	0.268	0.268	0.268	0.268	2D17DA
Output Torque (in•lbs)	77178	77178	77178	-	-	-	-	77178	77178	77178	77178	77178	77178	
Hollow Shaft OHL (lbs)	4810	4810	4810	-	-	-	-	4810	4810	4810	4810	4810	4810	
Solid Shaft OHL (lbs)	3930	3930	3930	-	-	-	-	3930	3930	3930	3930	3930	3930	
Input HP	-	-	-	-	-	-	-	-	-	-	-	-	-	2D17DB
Output Torque (in•lbs)	-	-	-	-	-	-	-	-	-	-	-	-	-	
Hollow Shaft OHL (lbs)	-	-	-	-	-	-	-	-	-	-	-	-	-	
Solid Shaft OHL (lbs)	-	-	-	-	-	-	-	-	-	-	-	-	-	
Input HP	-	-	-	-	-	-	-	-	-	-	-	-	-	2D17DC
Output Torque (in•lbs)	-	-	-	-	-	-	-	-	-	-	-	-	-	
Hollow Shaft OHL (lbs)	-	-	-	-	-	-	-	-	-	-	-	-	-	
Solid Shaft OHL (lbs)	-	-	-	-	-	-	-	-	-	-	-	-	-	
Input HP	1.02	0.857	0.690	0.582	0.536	0.536	0.536	0.536	0.268	0.268	0.268	0.268	0.268	2E17DA
Output Torque (in•lbs)	94702	94702	94702	94702	94702	94702	94702	94702	94702	94702	94702	94702	94702	
Hollow Shaft OHL (lbs)	5170	5170	5170	5170	5170	5170	5170	5170	5170	5170	5170	5170	5170	
Solid Shaft OHL (lbs)	4110	4110	4110	4110	4110	4110	4110	4110	4110	4110	4110	4110	4110	
Input HP	-	-	-	-	-	-	-	-	-	-	-	-	-	2E17DB
Output Torque (in•lbs)	-	-	-	-	-	-	-	-	-	-	-	-	-	
Hollow Shaft OHL (lbs)	-	-	-	-	-	-	-	-	-	-	-	-	-	
Solid Shaft OHL (lbs)	-	-	-	-	-	-	-	-	-	-	-	-	-	
Input HP	-	-	-	-	-	-	-	-	-	-	-	-	-	2E17DC
Output Torque (in•lbs)	-	-	-	-	-	-	-	-	-	-	-	-	-	
Hollow Shaft OHL (lbs)	-	-	-	-	-	-	-	-	-	-	-	-	-	
Solid Shaft OHL (lbs)	-	-	-	-	-	-	-	-	-	-	-	-	-	

Speed Reducers
Selection Tables

NOTE: Motor HP in **GRAY** is to overcome breakaway torque requirements in cold temperatures or high inertia applications. A torque limiting device is recommended to protect the unit or driven machine.

Dimensions

Single Reduction LHY(J)-2A100Y~2E175Y

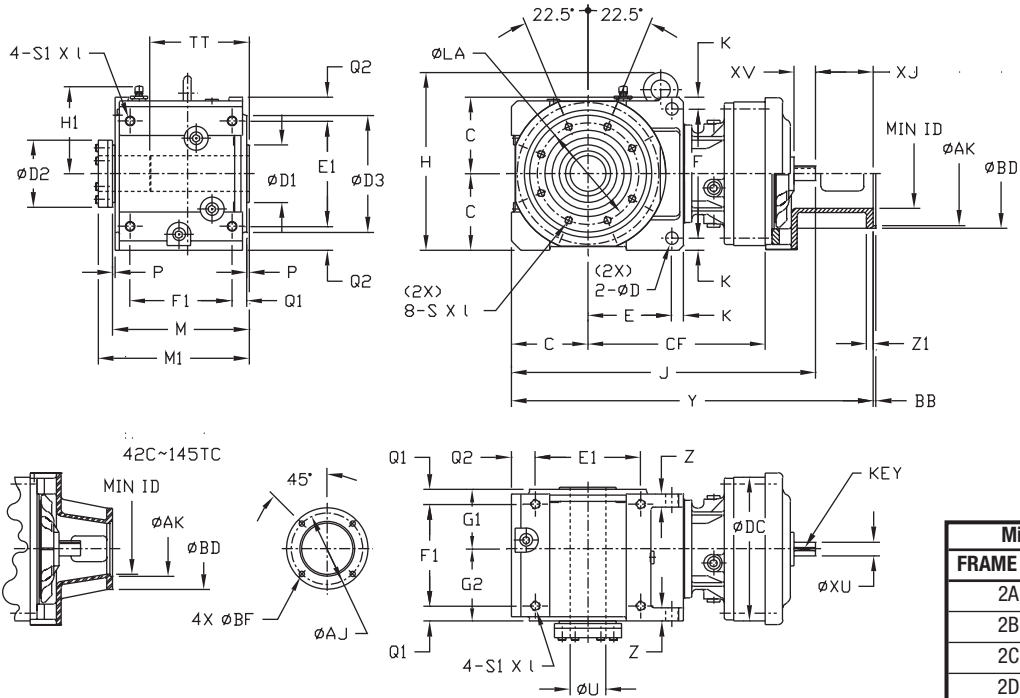

Min. Engagement	
FRAME SIZE	TT
2A	7.79
2B	9.33
2C	10.16
2D	11.82
2E	13.94

All dimensions are in inches.

Model	C	E	F	K	Z	ØD	E1	F1	Q1	Q2	S1 x l	M
2A100, 2A105 2A110, 2A115 2A120, 2A125 2A140, 2A145	4.33	4.61	7.48	0.59	0.87	0.71	5.91	6.30	0.91	1.38	M12x0.79	8.50
2B120, 2B125 2B140, 2B145 2B160, 2B165	5.12	5.71	8.66	0.79	1.02	0.87	7.48	7.68	1.06	1.38	M16x1.02	10.20
2C140, 2C145 2C160, 2C165 2C170, 2C175	6.30	6.89	10.63	0.98	1.18	1.02	8.66	8.39	1.22	1.97	M20x1.30	11.22
2D160, 2D165 2D170, 2D175	7.48	7.87	12.76	1.10	1.57	1.30	9.84	10.00	1.42	2.56	M24x1.57	13.39
2E170, 2E175	8.46	9.06	14.17	1.38	1.57	1.30	11.81	11.14	1.50	2.56	M24x1.57	14.69

Model	P	G1	G2	H	H1	ØLA	ØD3	S x l	M1	ØD1	ØD2	ØU	
												Std & Max	Min
2A100, 2A105 2A110, 2A115 2A120, 2A125 2A140, 2A145	0.20	3.78	4.33	10.87	5.16	6.10	6.89	M10x0.67	9.84	3.35	4.09	2-3/16	1-11/16
2B120, 2B125 2B140, 2B145 2B160, 2B165	0.20	4.80	5.00	12.13	5.94	6.89	7.83	M12x0.79	11.54	3.94	4.49	2-7/16	1-15/16
2C140, 2C145 2C160, 2C165 2C170, 2C175	0.20	4.88	5.94	14.33	7.20	8.35	9.61	M16x1.02	12.83	4.72	5.43	2-15/16	2-3/16
2D160, 2D165 2D170, 2D175	0.28	5.83	7.01	16.69	8.39	10.04	11.61	M20x1.30	15.00	5.51	5.98	3-7/16	2-7/16
2E170, 2E175	0.28	6.14	7.99	19.61	9.37	11.02	12.60	M20x1.38	16.30	6.30	6.69	3-15/16	2-15/16

Dimensions shown are for reference only and are subject to change without notice, unless certified.
Certified prints are available after receipt of an order; consult factory.

Single Reduction LHY(J)-2A100~2E175 Dimensions

With C-Face Adapter						
Model	NEMA C-Face	Y	Z1	Min. ID	XJ	Wt (lb)
2A100, 2A105	48C	17.87	0.47	2.44	2.16	111
	56C-145TC	18.33	0.47	4.21	2.63	113
	182TC-184TC	19.16	0.47	5.43	3.45	117
2A110, 2A115	56C	18.6	0.47	3.93	2.62	126
	143TC-145TC	18.6	0.47	3.93	2.62	126
	182TC-184TC	19.4	0.47	3.93	3.44	131
2A120, 2A125	143TC-145TC	19.40	0.47	4.21	2.63	133
	182TC-184TC	20.14	0.47	5.43	3.37	137
	213TC-215TC	21.14	1.47	5.43	4.37	147
2A140, 2A145	182TC-184TC	21.33	0.47	5.43	3.37	155
	213TC-215TC	21.95	1.10	5.43	4.00	161
	254TC-256TC	22.88	0.57	5.08	4.93	163
2B120, 2B125	56C-145TC	21.64	0.47	4.21	2.63	197
	182TC-184TC	22.39	0.47	5.43	3.37	201
	213TC-215TC	23.39	1.47	5.43	4.37	211
2B140, 2B145	143TC-145TC	22.63	0.47	4.21	2.63	217
	182TC-184TC	23.37	0.47	5.43	3.37	221
	213TC-215TC	24.00	1.10	5.43	4.00	227
2B160, 2B165	254TC-256TC	24.93	0.57	5.08	4.93	230
	182TC-184TC	25.46	0.57	5.71	3.37	304
	213TC-215TC	26.09	1.20	5.71	4.00	310
2B160, 2B165	254TC-256TC	26.84	0.57	5.71	4.75	306
	284TC-286TC	27.52	0.57	7.09	5.44	300
	324TC-326TC	28.59	0.57	7.87	6.50	311
2C140, 2C145	143TC-145TC	26.13	0.47	4.21	2.63	321
	182TC-184TC	26.88	0.47	5.43	3.37	325
	213TC-215TC	27.50	1.10	5.43	4.00	331
2C140, 2C145	254TC-256TC	28.43	0.57	5.08	4.93	333
	143TC-145TC	27.90	0.47	4.21	2.63	401
	182TC-184TC	28.65	0.57	5.71	3.37	405
2C160, 2C165	213TC-215TC	29.28	1.20	5.71	4.00	412
	254TC-256TC	30.03	0.57	5.71	4.75	408
	284TC-286TC	30.71	0.57	7.09	5.44	402
2C160, 2C165	324TC-326TC	31.78	0.57	7.87	6.50	412
	182TC-184TC	30.07	0.57	5.71	3.38	448
	213TC-215TC	30.70	1.20	5.71	4.00	454
2C170, 2C175	254TC-256TC	31.44	0.57	5.71	4.75	450
	284TC-286TC	32.13	0.57	7.87	5.44	461
	324TC-326TC	32.70	0.57	7.87	6.00	456
2D160, 2D165	143TC-145TC	31.92	0.47	4.21	2.63	549
	182TC-184TC	32.67	0.57	5.71	3.37	553
	213TC-215TC	33.29	1.20	5.71	4.00	559
2D160, 2D165	254TC-256TC	34.04	0.57	5.71	4.75	556
	284TC-286TC	34.73	0.57	7.09	5.44	549
	324TC-326TC	35.79	0.57	7.87	6.50	560
2D170, 2D175	182TC-184TC	33.22	0.57	5.71	3.38	587
	213TC-215TC	33.85	1.20	5.71	4.00	593
	254TC-256TC	34.59	0.57	5.71	4.75	589
2D170, 2D175	284TC-286TC	35.28	0.57	7.87	5.44	600
	324TC-326TC	35.85	0.57	7.87	6.00	594
	182TC-184TC	35.19	0.57	5.71	3.38	750
2E170, 2E175	213TC-215TC	35.81	1.20	5.71	4.00	756
	254TC-256TC	36.56	0.57	5.71	4.75	752
	284TC-286TC	37.25	0.57	7.87	5.44	763
2E170, 2E175	324TC-326TC	37.81	0.57	7.87	6.00	758

Free Shaft Input							
Model	ØXU	ØXV	Key	CF	ØDC	J	Wt (lb)
2A100, 2A105	0.625	0.98	3/16x3/16x0.75	9.33	5.91	15.71	106
2A110, 2A115	0.625	0.98	3/16x3/16x0.75	9.76	6.38	15.98	119
2A120, 2A125	0.750	1.38	3/16x3/16x1.02	9.57	8.03	16.77	123
2A140, 2A145	0.875	1.57	3/16x3/16x1.38	10.43	9.06	17.95	139
2B120, 2B125	0.750	1.38	3/16x3/16x1.02	11.02	8.03	19.02	187
2B140, 2B145	0.875	1.57	3/16x3/16x1.38	11.69	9.06	20.00	205
2B160, 2B165	1.125	1.77	1/4x1/4x1.77	12.83	11.81	22.09	258
2C140, 2C145	0.875	1.57	3/16x3/16x1.38	14.02	9.06	23.50	309
2C160, 2C165	1.125	1.77	1/4x1/4x1.77	14.84	11.81	25.28	359
2C170, 2C175	1.375	2.17	5/16x5/16x2.16	15.47	13.39	26.69	410
2D160, 2D165	1.125	1.77	1/4x1/4x1.77	17.68	11.81	29.29	507
2D170, 2D175	1.375	2.17	5/16x5/16x2.16	17.44	13.39	29.84	549
2E170, 2E175	1.375	2.17	5/16x5/16x2.16	18.43	13.39	31.81	712

NEMA C-Face Adapter	ØAJ	ØAK	ØBD	BB	ØBF
42C-48C	3.75	3.00	4.33	-	0.28
56C-145TC	5.87	4.50	6.69	-	0.43
182TC-256TC	7.25	8.50	8.98	0.22	0.55
284TC-286TC	9.00	10.50	11.10	0.22	0.55
324TC-326TC	11.00	12.50	14.17	0.22	0.71

All dimensions are in inches.

Dimensions shown are for reference only and are subject to change without notice, unless certified. Certified prints are available after receipt of an order; consult factory.

Speed Reducers

Dimensions

Dimensions

Double Reduction LHY(J)-2A10DAY~2E17DCY

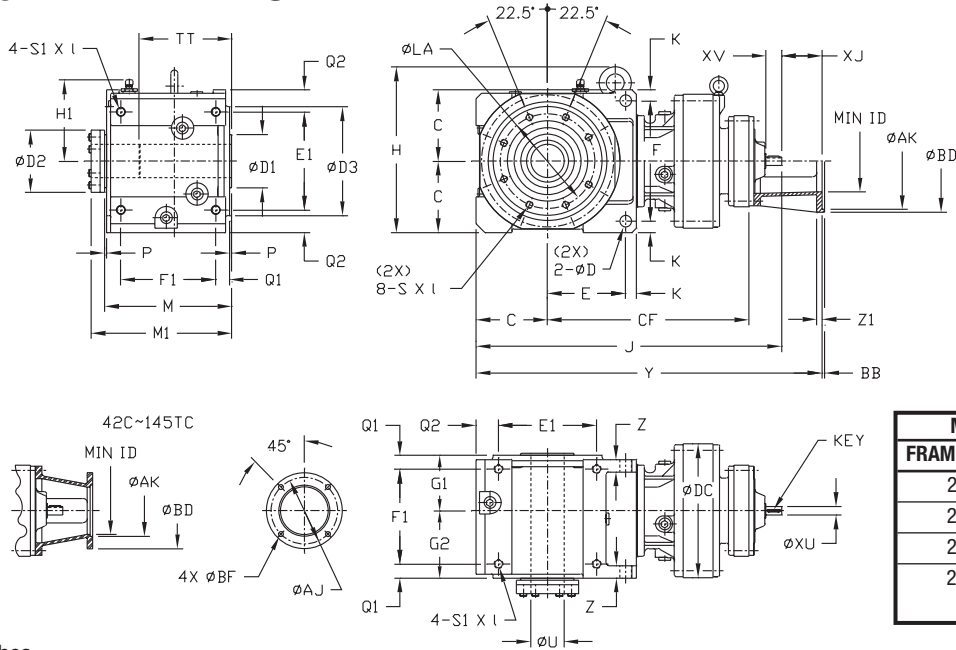

Dimensions shown are for reference only and are subject to change without notice, unless certified.

Certified prints are available after receipt of an order; consult factory.

Min. Engagement	
FRAME SIZE	TT
2A	7.79
2B	9.33
2C	10.16
2D	11.82

All dimensions are in inches.

Model	C	E	F	K	Z	ØD	E1	F1	Q1	Q2	S1 x l	M
2A10DA 2A12DA 2A12DB	4.33	4.61	7.48	0.59	0.87	0.71	5.91	6.30	0.91	1.38	M12x0.79	8.50
2B12DA 2B12DB 2B14DA 2B14DB	5.12	5.71	8.66	0.79	1.02	0.87	7.48	7.68	1.06	1.38	M16x1.02	10.20
2C14DA 2C14DB 2C14DC 2C16DA	6.30	6.89	10.63	0.98	1.18	1.02	8.66	8.39	1.22	1.97	M20x1.30	11.22
2D16DA 2D16DB 2D16DC 2D17DA 2D17DB 2D17DC	7.48	7.87	12.76	1.10	1.57	1.30	9.84	10.00	1.42	2.56	M24x1.57	13.39
2E17DA 2E17DB 2E17DC	8.46	9.06	14.17	1.38	1.57	1.30	11.81	11.14	1.50	2.56	M24x1.57	14.69

Model	P	G1	G2	H	H1	ØLA	ØD3	S x l	M1	ØD1	ØD2	ØU	
												Std & Max	Min
2A10DA 2A12DA 2A12DB	0.20	3.78	4.33	10.87	5.16	6.10	6.89	M10x0.67	9.84	3.35	4.09	2-3/16	1-11/16
2B12DA 2B12DB 2B14DA 2B14DB	0.20	4.80	5.00	12.13	5.94	6.89	7.83	M12x0.79	11.54	3.94	4.49	2-7/16	1-15/16
2C14DA 2C14DB 2C14DC 2C16DA	0.20	4.88	5.94	14.33	7.20	8.35	9.61	M16x1.02	12.83	4.72	5.43	2-15/16	2-3/16
2D16DA 2D16DB 2D16DC 2D17DA 2D17DB 2D17DC	0.28	5.83	7.01	16.69	8.39	10.04	11.61	M20x1.30	15.00	5.51	5.98	3-7/16	2-7/16
2E17DA 2E17DB 2E17DC	0.28	6.14	7.99	19.61	9.37	11.02	12.60	M20x1.38	16.30	6.30	6.69	3-15/16	2-15/16

Double Reduction LHY(J)-2C10DAY~2E17DCY Dimensions

All dimensions are in inches.

With C-Face Adapter						
Model	NEMA C-Face	Y	Z1	Min. ID	XJ	Wt (lb)
2A10DA	42C	19.42	0.47	2.44	1.78	113
	48C	19.80	0.47	2.44	2.16	113
	56C	20.20	0.47	3.15	2.56	116
2A12DA	42C	19.89	0.47	2.44	1.78	131
	48C	20.27	0.47	2.44	2.16	131
	56C	20.67	0.47	3.15	2.56	133
2A12DB	48C	21.02	0.47	2.44	2.16	139
	56C-145TC	21.48	0.47	4.21	2.63	142
2B12DA	42C	22.13	0.47	2.44	1.78	195
	48C	22.51	0.47	2.44	2.16	195
	56C	22.91	0.47	3.15	2.56	197
2B12DB	48C	23.26	0.47	2.44	2.16	203
	56C-145TC	23.73	0.47	4.21	2.63	206
2B14DA	48C	23.18	0.47	2.44	2.16	202
	56C	23.58	0.47	3.15	2.56	204
2B14DB	48C	23.81	0.47	2.44	2.16	212
	56C-145TC	24.28	0.47	4.21	2.63	215
2C14DA	48C	26.69	0.47	2.44	2.16	305
	56C	27.09	0.47	3.15	2.56	308
2C14DB	48C	27.31	0.47	2.44	2.16	316
	56C-145TC	27.78	0.47	4.21	2.63	318
2C14DC	143TC-145TC	28.02	0.47	4.21	2.63	320
	182TC-184TC	28.84	0.47	5.43	3.45	324
2C16DA	56C-145TC	28.69	0.47	4.21	2.63	369
2D16DA	48C	32.24	0.47	2.44	2.16	514
	56C-145TC	32.70	0.47	4.21	2.63	517
2D16DB	143TC-145TC	32.94	0.47	4.21	2.63	521
	182TC-184TC	33.76	0.47	5.43	3.45	525
2D16DC	182TC-184TC	34.16	0.47	5.43	3.37	542
	213TC-215TC	35.16	1.47	5.43	4.37	544
2D17DA	56C-145TC	32.51	0.47	4.21	2.63	548
2D17DB	143TC-145TC	32.74	0.47	4.21	2.63	552
	182TC-184TC	33.57	0.47	5.43	3.45	556
2D17DC	182TC-184TC	34.47	0.47	5.43	3.37	569
	213TC-215TC	35.47	1.47	5.43	4.37	579
2E17DA	48C	34.01	0.47	2.44	2.16	708
	56C-145TC	34.48	0.47	4.21	2.63	711
2E17DB	143TC-145TC	34.71	0.47	4.21	2.63	715
	182TC-184TC	35.54	0.47	5.43	3.45	719
2E17DC	182TC-184TC	36.44	0.47	5.43	3.37	732
	213TC-215TC	37.44	1.47	5.43	4.37	743

Free Shaft Input							
Model	ØXU	ØXV	Key	CF	ØDC	J	Wt (lb)
2A10DA	0.500	0.98	1/8x1/8x0.71	11.22	5.91	17.64	110
2A12DA	0.500	0.98	1/8x1/8x0.71	11.69	8.03	18.11	128
2A12DB	0.625	0.98	3/16x3/16x0.75	12.17	8.03	18.86	135
2B12DA	0.500	0.98	1/8x1/8x0.71	13.15	8.03	20.35	192
	0.625	0.98	3/16x3/16x0.75	13.62	8.03	21.10	198
	0.500	0.98	1/8x1/8x0.71	13.82	9.06	21.02	198
2B14DB	0.625	0.98	3/16x3/16x0.75	14.17	9.06	21.65	207
2C14DA	0.500	0.98	1/8x1/8x0.71	16.14	9.06	24.53	302
2C14DB	0.625	0.98	3/16x3/16x0.75	16.50	9.06	25.16	311
2C14DC	0.625	0.98	3/16x3/16x0.75	17.05	9.06	25.39	313
2C16DA	0.625	0.98	3/16x3/16x0.75	17.40	11.81	26.06	362
2D16DA	0.625	0.98	3/16x3/16x0.75	20.24	11.81	30.08	509
2D16DB	0.625	0.98	3/16x3/16x0.75	20.79	11.81	30.31	514
2D16DC	0.750	1.38	3/16x3/16x1.02	20.87	11.81	31.22	529
2D17DA	0.625	0.98	3/16x3/16x0.75	20.04	13.39	29.88	540
2D17DB	0.625	0.98	3/16x3/16x0.75	20.59	13.39	30.12	545
2D17DC	0.750	1.38	3/16x3/16x1.02	20.75	13.39	31.10	556
2E17DA	0.625	0.98	3/16x3/16x0.75	21.02	13.39	31.85	703
2E17DB	0.625	0.98	3/16x3/16x0.75	21.57	13.39	32.09	708
2E17DC	0.750	1.38	3/16x3/16x1.02	21.73	13.39	33.07	719

NEMA C-Face Adapter	ØAJ	ØAK	ØBD	BB	ØBF
42C-48C	3.75	3.00	4.33	-	0.28
56C-145TC	5.87	4.50	6.69	-	0.43
182TC-256TC	7.25	8.50	8.98	0.22	0.55

Speed Reducers

Dimensions

Dimensions shown are for reference only and are subject to change without notice, unless certified. Certified prints are available after receipt of an order; consult factory.

This page intentionally left blank.

Speed
Reducers



3

Gearmotors

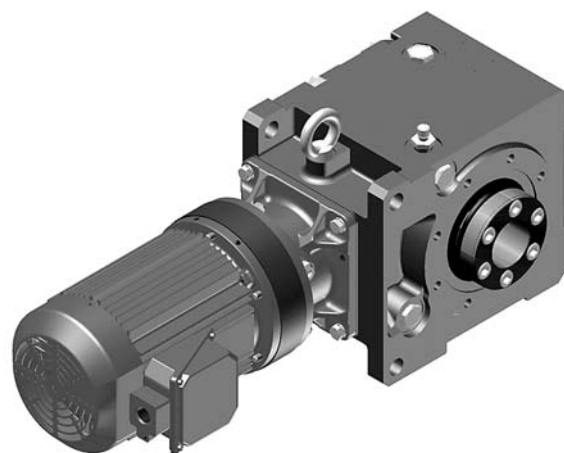

How to select a Gearmotor

Step 1: Collect data about your application

Before starting you need to know the:

- **Application** (e.g. Conveyor, Mixer, etc.)
- **Hours of Operation per day**
- **Motor Horsepower (HP) and Speed (RPM)**
- **Desired Output Speed**
- **Mounting Position and Style**
- **Overhung or Thrust Loads**
- **Bore Dimensions, inch or metric**
- **Electrical Specifications**

Step 2: Choose a Mounting Position

Find the correct Mounting Position from the *Mounting Positions Table* on the right.

Step 3: Select a Frame Size

3A: Find the **Load Classification** of your application in the *AGMA Load Classification Tables* on pages 3.6 and 3.7.

3B: Go to the *Gearmotor Selection Table* that corresponds to the desired **Mounting Position** and **Motor HP**. Find the **Output Speed** closest to the desired output speed.

3C: Locate the **Service Class** in the *Gearmotor Selection Table* for your application and select the **Frame Size SELECTION** that matches the HP, Output Speed, and Service Class.

Step 4: Verify Dimensions

Use the Dimensions information on pages 3.38–3.45 to verify that the selected Frame Size is appropriate.

Step 5: Choose a Bushing Bore Size

Choose a Taper Grip® Bushing Bore Size from the *Stock Bushing Bore Size Table*.

Step 6: Choose Options

The following options may apply:

- Brakemotor**
- Washdown Modifications**
- Breather**
- Bushing Cover**

Please see the *Cyclo BBB pricelist*, or visit our website at www.smcyclo.com for available modifications.

Step 7: Configure a Model Number

Go to page 3.4 to configure a model number.

Note: You will use the information you gather from the procedure on this page to Configure a Model Number.



Mounting Positions

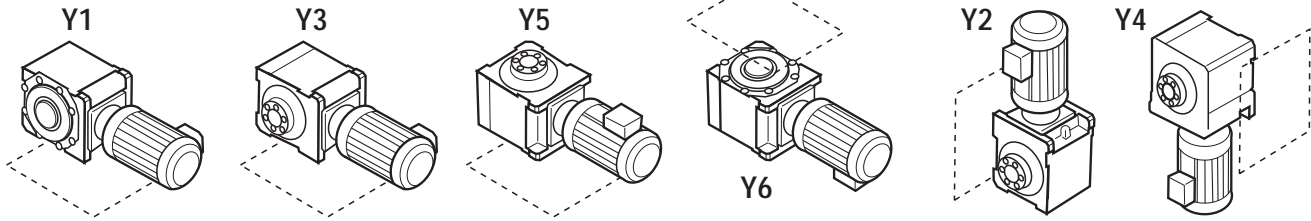

Select a Frame Size

Gearmotors

60 Hz, 1750 RPM Gearmotor Selection Tables

• Mounting Position

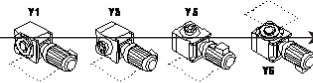

Horizontal Motor Shaft
Y1, Y3, Y5, Y6 Mounting Positions

• Motor HP

1/4 HP

• Output Speed

• Service Class

• SELECTION

Output Speed RPM	Output Torque in-lb	Service Factor		SELECTION			Overhung Load (lbs)		Dimension Page LHYM
		SF	AGMA Class	HP Symbol	Frame Size	Ratio	Hollow Shaft	Solid Shaft	
2.56	5350	1.57	II	02	2A10DA	683	1120	990	3.42-43
		1.64	II	02	2A12DA	683	1120	990	3.42-43
		2.15	III	02	2B12DA	683	2070	1640	3.42-43
2.56	5350	1.32	I	02	2A10DA	809	1120	990	3.42-43
		1.38	I	02	2A12DA	809	1120	990	3.42-43
		2.15	III	02	2B12DA	809	2070	1640	3.42-43
1.83	7450	1.12	I	02	2A10DA	956	1120	990	3.42-43
		1.17	I	02	2A12DA	956	1120	990	3.42-43
		2.15	III	02	2B12DA	956	2070	1640	3.42-43
1.57	8730	1.00	I	02	2A12DA	1117	1120	990	3.42-43
		2.00	III	02	2B12DA	1117	2070	1640	3.42-43
		2.00	III	02	2B14DA	1117	2070	1640	3.42-43
1.33	10300	0.85	-	02	2A12DA	1320	1120	990	3.42-43
		1.69	II	02	2B12DA	1320	2070	1640	3.42-43
		1.69	II	02	2B14DA	1320	2070	1640	3.42-43
1.06	12930	2.15	III	02	2C14DA	1320	3480	2850	3.42-43
		1.35	I	02	2B12DA	1656	2070	1640	3.42-43
		1.35	I	02	2B14DA	1656	2070	1640	3.42-43
		2.15	III	02	2C14DA	1656	3480	2850	3.42-43

Gearmotors

Selection Tables

Gearmotors

How to Select

STOCK BUSHING BORES

Size	Inch Sizes	Metric Sizes	Min. Bore
A	1 ¹⁵ / ₄₁₆ , 2 ³¹ / ₄₁₆	50, 55	1 ¹¹ / ₄₁₆
B	2 ³¹ / ₄₁₆ , 2 ⁷ / ₄₁₆	60, 65	1 ¹⁵ / ₄₁₆
C	2 ⁷ / ₄₁₆ , 2 ¹⁵ / ₄₁₆	65, 75	2 ³¹ / ₄₁₆
D	2 ¹⁵ / ₄₁₆ , 3 ⁷ / ₄₁₆	75, 85	2 ⁷ / ₄₁₆
E	3 ⁷ / ₄₁₆ , 3 ¹⁵ / ₄₁₆	90, 100	2 ¹⁵ / ₄₁₆

**Min. Bore is also stock but needs slitting.

For special circumstances in selecting a Frame Size such as:

- Overhung Load
- Thrust Loads
- Radial Loads
- Shock Loading

Consult Appendix, pages 5.2-5.6.

If Overhung Load is present, any Overhung Load must be checked against the capacity of the selection.



Configure a Model Number

Output Shaft Orientation

Type	Prefix
Horizontal	H
Vertical	V
Vertical Up (Solid Shaft)	W

Mounting Style

Type	Prefix
Shaft Mount (Hollow Shaft)	Y
Flange (Solid Shaft)	F
Foot (Solid Shaft)	H

Input Connection

Input Connection	Prefix	
	Reducer	Gearmotor
Integral Motor		M
Free input Shaft		
C-Face Adaptor		
Hollow Input Shaft (Size A Only)		

Modification

	Prefix
Special	S
Standard	

Gearmotor HP (applies only to 1750 RPM)

HP	Prefix
1/8	01
1/4	02
1/3	03
1/2	05
3/4	08
1	1
1 1/2	1H
2	2
3	3
5	5
7 1/2	8
10	10
15	15
20	20
25	25
30	30
40	40

Frame Size

Single Reduction				
2A100	2A140	2B145	2C160	2D165
2A105	2A145	2B160	2C165	2D170
2A110	2B120	2B165	2C170	2D175
2A115	2B125	2C140	2C175	2E170
2A120	2B140	2C145	2D160	2E175
2A125				
Double Reduction				
2A10DA	2B14DA	2C14DC	2D16DB	2D17DC
2A12DA	2B14DB	2C16DA	2D16DC	2E17DA
2A12DB	2C14DA	2C16DB	2D17DA	2E17DB
2B12DA	2C14DB	2D16DA	2D17DB	2E17DC
2B12DB				

When ordering, the following information should be included:

- Motor Specification (230/460 VAC 60 Hz is supplied, unless otherwise specified)
- NEMA frame size for C-face adaptor
- Bushing Bore size must be supplied

Optional conduit box positions must be specified, otherwise Y1 is supplied.

Gearmotors

Nomenclature

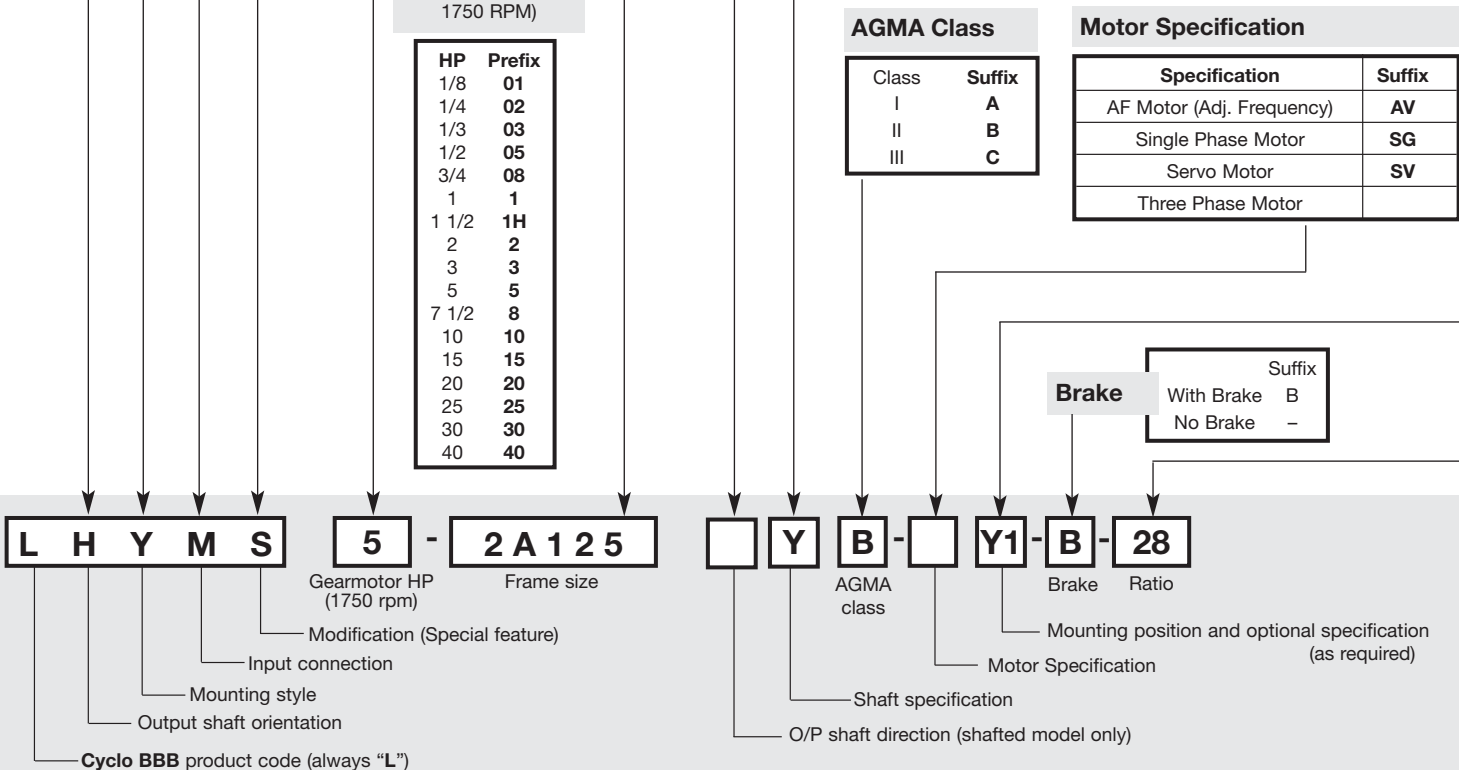

Nomenclature

Output Shaft Direction (Shafted Model Only)

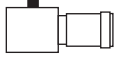
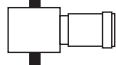
Projects to Left Side	L	
Projects to Right Side	R	
Projects to Both Left/Right Sides	T	

Note: When viewed from motor end.

Shaft Specifications

Input Shaft	OUTPUT SHAFT		Suffix
	Hollow	Solid	
mm	Key (mm)	mm	
DIN	Key (DIN)	DIN	E
Inch	Key (Inch)	Inch	K
mm	Taper Grip		M
DIN	Taper Grip		G
Inch	Taper Grip		Y

Nominal and Exact Ratio

BBB with Planetary Input				BBB with Cyclo Input Single Reduction			
Input Ratio	Nominal Ratio	BBB Frame Sz.	Exact Ratio	Input Ratio	Nominal Ratio	BBB Frame Sz.	Exact Ratio
3.00	11	2A10	10.500	6	21		21.0
N/A	N/A	2A11	N/A	8	28		28.0
3.00	11	2A12	10.500	11	39		38.5
3.11	11	2A14	10.885	13	46		45.5
3.00	11	2B12	10.500	15	53		52.5
3.11	11	2B14	10.885	17	60		59.5
3.10	11	2B16	10.850	21	74		73.5
3.11	11	2C14	10.885	25	88	ALL	87.5
3.10	11	2C16	10.850	29	102		101.5
3.10	11	2C17	10.850	35	123		122.5
3.10	11	2D16	10.850	43	151		150.5
3.10	11	2D17	10.850	51	179		178.5
4.80	18	2A10	16.800	59	207		206.5
N/A	N/A	2A11	N/A	71	249		248.5
4.89	18	2A12	17.115	87	305		304.5
5.00	18	2A14	17.500	Double Reduction			
4.89	18	2B12	17.115	Input Ratio	Nominal Ratio	BBB Frame Sz.	Exact Ratio
5.00	18	2B14	17.500	104	364		364.0
5.08	18	2B16	17.780	121	424		423.5
5.00	18	2C14	17.500	143	501		500.5
5.08	18	2C16	17.780	165	578		577.5
5.05	18	2C17	17.675	195	683		682.5
5.08	18	2D16	17.780	231	809		808.5
5.05	18	2D17	17.675	273	956		955.5
5.05	18	2E17	17.675	319	1117		1116.5
				377	1320		1319.5
				473	1656		1655.5
				559	1957		1956.5
				649	2272		2271.5
				731	2559		2558.5
				841	2944	ALL	2943.5
				1003	3511		3510.5
				1247	4365		4364.5
				1479	5177		5176.5
				1849	6472		6471.5
				2065	7228		7227.5
				2537	8880		8879.5
				3045	10568		10657.5
				3481	12184		12183.5
				4437	15530		15529.5
				5133	17966		17965.5
				6177	21620		21619.5
				7569	26492		26491.5

Gearmotors
Nomenclature

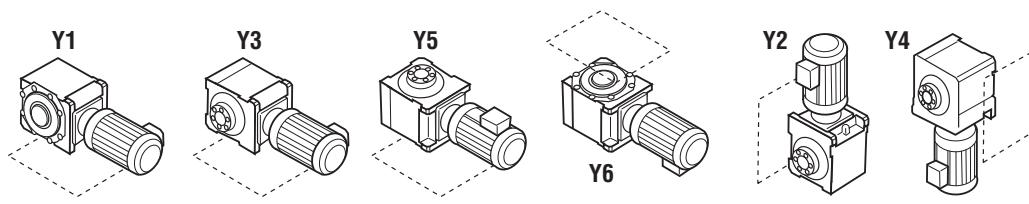

Mounting Positions

Nominal and Exact Ratio

Nomenclature Example:
LVYM – 2B125YB – AVY5 – 53

L – Cyclo Bevel Buddybox	2B125 – Frame Size
V – Vertical	B – AGMA Class II
Y – Shaft Mount (Hollow Shaft)	AV – Adj. Frequency Motor
M – Integral Motor	Y5 – Installation Position
5 – 5 HP, 1750 RPM	53 – Ratio

AGMA Load Classifications: Gearmotors

Gearmotor Classification

GEARMOTOR CLASS

DURATION OF SERVICE	UNIFORM LOAD	MODERATE SHOCK LOAD	HEAVY SHOCK LOAD
Intermittent 3 Hr. per day	Class I	Class I	Class II
Up to 10 Hr. per day	Class I	Class II	Class III
24 Hr. per day	Class II	Class III	—

Class I For steady loads not exceeding normal motor rating, 8 to 10 hours a day. Moderate shock loads where service is intermittent (AGMA Service Factor: 1.0).

Class II For steady loads not exceeding normal motor rating and 24 hours a day service. Moderate shock loads for 8 hours a day (AGMA Service Factor: 1.4).

Class III For moderate shock loads for 24 hours a day. Heavy shock loads for 8 hours a day (AGMA Service Factor: 2.0).

Gearmotors

AGMA Tables

Load Classification by INDUSTRY

Application	Class		Application	Class		Application	Class		Application	Class	
	Up to 10 Hr. per day	24 Hr. per day		Up to 10 Hr. per day	24 Hr. per day		Up to 10 Hr. per day	24 Hr. per day		Up to 10 Hr. per day	24 Hr. per day
Brewing & Distilling			Lumber Industry			Oil Well Pumping	Refer to Factory		Tire Building Machines	Refer to Factory	
Bottling Machinery	I	II	Barkers—			Paraffin Filter Press	II	II	Tire, Tube Press		
Brew Kettles, Cont. Duty	—	II	Spindle Feed	II	III	Rotary Kilns	II	II	Openers	II	II
Can Filling Machines	I	II	Barkers—			Paper Mills			Tubers & Stainers	II	II
Cookers—Cont. Duty	—	II	Main Drive	III	III	Agitators (Mixers)	II	II	Sewage Disposal		
Mash Tubs—Cont. Duty	—	II	Carriage Drive	Refer to Factory		Barker—Auxiliaries—			Aerators	Refer to Factory	
Scale Hoppers—			Conveyors			Hyd.	—	III	Bar Screens	I	II
Frequent Starts	II	II	Burner	II	III	Barker, Mechanical	—	III	Chemical Feeders	I	II
Clay Working Industry			Main or Heavy Duty	II	III	Barking Drum	—	III	Collectors	I	II
Brick Press	III	III	Main Log	III	III	Beater & Pulper	—	II	Dewatering Screens	II	II
Briquette Machines	III	III	Re-Saw			Bleacher	—	II	Grit Collectors	I	II
Clay Working Machinery	II	II	Merry-Go-Round	II	III	Calenders	—	II	Sludge Collectors	II	II
Pug Mills	II	II	Slab	III	III	Calenders—Super	—	II	Scum Breakers	II	II
Distilling (See Brewing)			Transfer	II	III	Converting Mach.—			Slow or Rapid Mixers	II	II
Dredges			Chains—Floor	II	III	Except Cutters—			Sludge Collectors	I	II
Cable Reels	II	—	Chains—Green	II	III	Platers	—	II	Thickeners	II	II
Conveyors	II	II	Cut-Off Saws—Chain	II	III	Conveyors	—	II	Vacuum Filters	II	II
Cutter Head Drives	III	III	Cut-Off Saws—Drag	II	III	Couch	—	II	Textile Industry		
Jig Drives	III	III	Debarking Drums	III	III	Cutters, Platers	—	II	Batchers	II	II
Maneuvering Winches	II	—	Feeds—Edger	II	III	Cylinders	—	II	Calenders	II	II
Pumps	II	II	Feeds—Gang	III	III	Dryers	—	II	Card Machines	II	II
Screen Drives	III	III	Feeds—Trimmer	II	III	Felt Stretchers	—	II	Cloth Finishing Machines		
Stackers	II	II	Log Deck	III	III	Felt Whippers	—	III	(Calenders, Dryers,		
Utility Winches	II	—	Log Hauls—Incline,			Jordans	—	II	Pads, Tenters,		
Food Industry			Well Type	III	III	Log Haul	—	III	Washers)	II	II
Beet Slicers	II	II	Log Turning Devices	III	III	Presses	—	II	Dry Cans	II	II
Bottlings, Can Filling Mach.	I	II	Planer Feed	II	III	Pulp Machine Reels	—	II	Dyeing Machinery	II	II
Cereal Cookers	I	II	Planer Tilting Hoists	II	III	Stock Chests	—	II	Knitting Machinery	II	II
Dough Mixers	II	II	Rolls—Live—Off			Suction Rolls	—	II	Looms, Mangles,	Refer to Factory	
Meat Grinders	II	II	Bearing—Roll Cases	III	III	Washers &			Nappers	II	II
			Sorting Table	II	III	Thickeners	—	II	Range Drives	Refer to Factory	
			Tipple Hoist	II	III	Winders	—	II	Soapers, Spinners	II	II
			Transfers—Chain	II	III	Rubber Industry			Tenter Frames	II	II
			Transfers—Craneway	II	III	Mixer	III	III	Winders	II	II
			Tray Drives	II	III	Rubber Calender	II	II	Yarn Preparatory		
			Oil Industry			Rubber Mill			Machinery (Cards,		
			Chillers	II	II	(2 or more)	II	II	Spinners,		
						Sheeter	II	II	Slashers)	II	II



Load Classification by APPLICATION

Application	Class		Application	Class		Application	Class		Application	Class	
	Up to 10 Hr. per day	24 Hr. per day		Up to 10 Hr. per day	24 Hr. per day		Up to 10 Hr. per day	24 Hr. per day		Up to 10 Hr. per day	24 Hr. per day
Agitators Pure Liquids Liquids and Solids Liquids – Variable Density Semi-liquids – Variable Density	I	II	Jig Drives Maneuvering Winches Pumps Screen Drive Stackers Utility Winches	III	III	Tray Drives Veneer Lathe Drives	II	III	Pullers Barge Haul	III	III
Blowers Centrifugal Lobe Vane	I	II	Elevators Bucket – Uniform Load Bucket – Heavy Load Bucket – Continuous Centrifugal Discharge Escalators Freight Gravity Discharge Man Lifts Passenger Service – Hand Lift	I	II	Machine Tools Bending Roll Notching Press – Belt Driven Plate Planer Punch Press – Gear Driven Tapping Machines Other Machine Tools Main Drives Auxiliary Drives	II	II	Pumps Centrifugal Proportioning Reciprocating Single Acting 3 or more Cylinders Double Acting 2 or more Cylinders Single Acting 1 or 2 Cylinders Double Acting Single Cylinder Rotary – Gear Type – Lobe, Vane	I	II
Brewing and Distilling Bottling Machinery Brew Kettles – Continuous Duty Cookers – Continuous Duty Mash Tubs – Continuous Duty Scale Hopper Frequent Starts	I	II	Fans Centrifugal Cooling Towers Induced Draft Forced Draft Induced Draft Large (Mine, etc.) Large Industrial Light (Small Diameter)	III	–	Metal Mills Bridle Roll Drives Draw Bench – Carriage Draw Bench – Main Drive Forming Machines Pinch Dryer & Scrubber Rolls, Reversing Slitters Table Conveyors Non-Reversing Reversing Winding Reels – Strip Wire Drawing & Flattening Machine Wire Winding Machine	III	III	Rubber Industry Mixer Rubber Calender Rubber Mill (2 or more) Sheeter Tire Building Machines Tire & Tube Press Openers Tubers & Strainers	II	II
Can Filling Machines	I	II	Feeders Apron Belt Disc Reciprocating Screw	II	II	Mills, Rotary Type Ball Cement Kilns Dryers & Coolers Kilns Pebble Rod Tumbling Barrels	III	III	Sewage Disposal Equipment Aerators Bar Screens Chemical Feeders Collectors, Circuline or Straightline Dewatering Screens Grit Collectors Scum Breakers Slow or Rapid Mixers Sludge Collectors Thickeners Vacuum Filters	II	II
Cane Knives	II	II	Food Industry Beet Slicer Cereal Cooker Dough Mixer Meat Grinders	II	II	Mixers Concrete Mixers, Continuous Concrete Mixers, Intermittent Constant Density Variable Density	II	II	Screens Air Washing Rotary – Stone or Gravel Traveling Water Intake	I	II
Car Dumpers	III	–	Generators – (Not Welding)	I	II	Oil Industry Chillers Oil Well Pumping Paraffin Filter Press Rotary Kilns	II	II	Slab Pushers Steering Gear Stokers	II	II
Car Pullers – Intermittent Duty	I	–	Hammer Mills	III	III	Paper Mills Aerators Agitators (Mixers) Barker Auxiliaries, Hydraulic Barker, Mechanical Barking Drum Beater & Pulper Bleacher Calenders Calenders – Super Converting Machines, except Cutters, Platers Conveyors Conveyors, Log Couch Cutters, Platers Cylinders Dryers Felt Stretcher Felt Whipper Jordans Presses Pulp Machines, Reel Stock Chests Suction Roll Washers and Thickeners Winders	II	II	Textile Industry Batches Calenders Card Machines Cloth Finishing Machines (Washers, Pads, Tenters) (Dryers, Calenders, etc.) Dry Cans Dryers Dyeing Machinery Knitting Machines (Looms, etc.) Looms Mangles Nappers Pads Range Drives Slashers Soapers Spinners Teneter Frames Washers Winders (Other than Batches) Yarn Preparatory Machines (Cards, Spinners, Slashers, etc.)	II	II
Clarifiers	I	II	Laundry Washers Reversing	II	II	Printing Presses	I	II	Windlass	II	II
Classifiers	II	II	Laundry Tumblers	II	II						
Clay Working Machinery Brick Press Briquette Machine Clay Working Machinery Pug Mill	III	III	Line Shafts Heavy Shock Load Moderate Shock Load Uniform Load	III	III						
Compressors Centrifugal Lobe Reciprocating Multi-Cylinder Single Cylinder	I	II	Lumber Industry Barkers – Spindle Feed Barkers – Main Drive Carriage Drive Conveyors – Burner Conveyors – Main or Heavy Duty Conveyors – Main Log Conveyors – Merry-Go-Round Conveyors – Slab Conveyors – Transfer Conveyors – Waste Chains – Floor Chains – Green Cut-Off Saws – Chain Cut-Off Saws – Drag Debarking Drums Feeds – Edger Feeds – Gang Feeds – Trimmer Log Deck Log Hauls – Incline Well Type Log Turning Devices Planer Feed Planer Tilting Hoists Rolls – Live – Off Brg. – Roll Cases Sorting Table Tipple Hoist Transfers – Chain Transfers – Craneway	II	II						
Conveyors – Uniformly Loaded or Fed Apron Assembly Belt Bucket Chain Flight Oven Screw	I	II		Refer to Factory	Refer to Factory						
Conveyors – Heavy Duty Not Uniformly Fed Apron Assembly Belt Bucket Chain Flight Live Roll (Package) Oven Reciprocating Screw Shaker	II	II		Refer to Factory	Refer to Factory						
Cranes and Hoists Main Hoists Heavy Duty Medium Duty Reversing Skip Hoists Trolley Drive Bridge Drive	III	III		Refer to Factory	Refer to Factory						
Crushers Ore Stone	III	III		Refer to Factory	Refer to Factory						
Dredges Cable Reels Conveyors Cutter Head Drives	II	–		Refer to Factory	Refer to Factory						

Gearmotors

AGMA Tables

Gearmotor Selection Tables 60 Hz, 1750 RPM

Horizontal Motor Shaft Y1, Y3, Y5, Y6 Mounting Positions

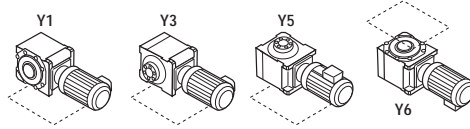

1/8 HP

Output Speed RPM	Output Torque in•lb	Service Factor		SELECTION			Overhung Load (lbs)		Dimension Page LHYM
		SF	AGMA Class	HP Symbol	Frame Size	Ratio	Hollow Shaft	Solid Shaft	
4.81	1425	4.29	III	01	2A10DA	364	1120	990	3.42-43
4.13	1660	4.29	III	01	2A10DA	424	1120	990	3.42-43
3.49	1960	4.27	III	01	2A10DA	501	1120	990	3.42-43
3.03	2260	3.70	III	01	2A10DA	578	1120	990	3.42-43
2.56	2670	3.13	III	01	2A10DA	683	1120	990	3.42-43
2.16	3170	2.64	III	01	2A10DA	809	1120	990	3.42-43
1.83	3745	2.24	III	01	2A10DA	956	1120	990	3.42-43
1.57	4365	1.91	II	01	2A10DA	1117	1120	990	3.42-43
		2.00	III	01	2A12DA	1117	1120	990	3.42-43
1.33	5150	1.62	II	01	2A10DA	1320	1120	990	3.42-43
		1.70	II	01	2A12DA	1320	1120	990	3.42-43
		3.38	III	01	2B12DA	1320	2070	1640	3.42-43
1.06	6465	1.29	I	01	2A10DA	1656	1120	990	3.42-43
		1.35	I	01	2A12DA	1656	1120	990	3.42-43
		2.69	III	01	2B12DA	1656	2070	1640	3.42-43
0.894	7665	1.09	I	01	2A10DA	1957	1120	990	3.42-43
		1.14	I	01	2A12DA	1957	1120	990	3.42-43
		2.28	III	01	2B12DA	1957	2070	1640	3.42-43
0.770	8900	0.99	-	01	2A12DA	2272	1120	990	3.42-43
		1.96	II	01	2B12DA	2272	2070	1640	3.42-43
0.684	10020	0.87	-	01	2A12DA	2559	1120	990	3.42-43
		1.74	II	01	2B12DA	2559	2070	1640	3.42-43
0.585	11715	1.52	II	01	2B12DA	2994	2070	1640	3.42-43
0.498	13760	1.27	I	01	2B12DA	3511	2070	1640	3.42-43
0.401	17090	1.02	I	01	2B12DA	4365	2070	1640	3.42-43

1/4 HP

Output Speed RPM	Output Torque in•lb	Service Factor		SELECTION			Overhung Load (lbs)		Dimension Page LHYM
		SF	AGMA Class	HP Symbol	Frame Size	Ratio	Hollow Shaft	Solid Shaft	
8.45	1715	3.54	III	02	2A105	207	1120	990	3.38-39
7.03	2061	2.81	III	02	2A105	249	1120	990	3.38-39
5.74	2525	2.83	III	02	2A105	305	1120	990	3.38-39
4.81	2850	2.15	III	02	2A10DA	364	1120	990	3.42-43
4.20	3451	1.05	I	02	2A100	417	1120	990	3.38-39
		1.43	II	02	2A105	417	1120	990	3.38-39
4.13	3319	2.15	III	02	2A10DA	424	1120	990	3.42-43
3.49	3925	2.14	III	02	2A10DA	501	1120	990	3.42-43
3.03	4525	1.85	II	02	2A10DA	578	1120	990	3.42-43
		1.94	II	02	2A12DA	578	1120	990	3.42-43

60 Hz, 1750 RPM Gearmotor Selection Tables

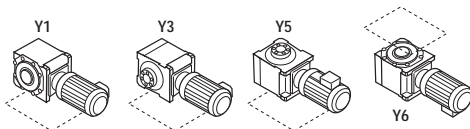

Horizontal Motor Shaft Y1, Y3, Y5, Y6 Mounting Positions

1/4 HP

Output Speed RPM	Output Torque in•lb	Service Factor		SELECTION			Overhung Load (lbs)		Dimension Page LHYM
		SF	AGMA Class	HP Symbol	Frame Size	Ratio	Hollow Shaft	Solid Shaft	
2.56	5350	1.57	II	02	2A10DA	683	1120	990	3.42-43
		1.64	II	02	2A12DA	683	1120	990	3.42-43
		2.15	III	02	2B12DA	683	2070	1640	3.42-43
2.56	5350	1.32	I	02	2A10DA	809	1120	990	3.42-43
		1.38	I	02	2A12DA	809	1120	990	3.42-43
		2.15	III	02	2B12DA	809	2070	1640	3.42-43
1.83	7490	1.12	I	02	2A10DA	956	1120	990	3.42-43
		1.17	I	02	2A12DA	956	1120	990	3.42-43
		2.15	III	02	2B12DA	956	2070	1640	3.42-43
1.57	8730	1.00	I	02	2A12DA	1117	1120	990	3.42-43
		2.00	III	02	2B12DA	1117	2070	1640	3.42-43
		2.00	III	02	2B14DA	1117	2070	1640	3.42-43
1.33	10300	0.85	-	02	2A12DA	1320	1120	990	3.42-43
		1.69	II	02	2B12DA	1320	2070	1640	3.42-43
		1.69	II	02	2B14DA	1320	2070	1640	3.42-43
		2.15	III	02	2C14DA	1320	3480	2850	3.42-43
1.06	12930	1.35	I	02	2B12DA	1656	2070	1640	3.42-43
		1.35	I	02	2B14DA	1656	2070	1640	3.42-43
		2.15	III	02	2C14DA	1656	3480	2850	3.42-43
0.894	15330	1.14	I	02	2B12DA	1957	2070	1640	3.42-43
		1.14	I	02	2B14DA	1957	2070	1640	3.42-43
		2.15	III	02	2C14DA	1957	3480	2850	3.42-43
0.770	17800	0.98	-	02	2B12DA	2272	2070	1640	3.42-43
		1.96	II	02	2C14DA	2272	3480	2850	3.42-43
0.684	20040	0.87	-	02	2B14DA	2559	2070	1640	3.42-43
		1.74	II	02	2C14DA	2559	3480	2850	3.42-43
0.594	23075	1.51	II	02	2C14DA	2944	3480	2850	3.42-43
0.498	27525	1.27	I	02	2C14DA	3511	3480	2850	3.42-43
0.401	34180	1.02	I	02	2C14DA	4365	3480	2850	3.42-43
0.242	56640	1.04	I	02	2D16DA	7228	4810	3930	3.44-45
0.164	83585	0.94	-	02	2E17DA	10658	5170	4110	3.44-45

Gearmotors

Selection
Tables

1/3 HP

Output Speed RPM	Output Torque in•lb	Service Factor		SELECTION			Overhung Load (lbs)		Dimension Page LHYM
		SF	AGMA Class	HP Symbol	Frame Size	Ratio	Hollow Shaft	Solid Shaft	
9.78	1956	3.10	III	03	2A105	179	1120	990	3.38-39
8.45	2264	2.72	III	03	2A105	207	1120	990	3.38-39
7.03	2721	1.74	II	03	2A100	249	1120	990	3.38-39
		2.18	III	03	2A105	249	1120	990	3.38-39
5.74	3333	1.73	II	03	2A100	305	1120	990	3.38-39
		2.26	III	03	2A105	305	1120	990	3.38-39

Gearmotor Selection Tables 60 Hz, 1750 RPM

Horizontal Motor Shaft Y1, Y3, Y5, Y6 Mounting Positions

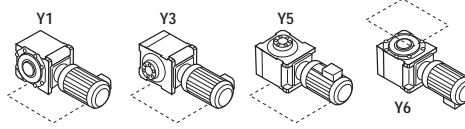

1/3 HP

Output Speed RPM	Output Torque in•lb	Service Factor		SELECTION			Overhung Load (lbs)		Dimension Page LHYM
		SF	AGMA Class	HP Symbol	Frame Size	Ratio	Hollow Shaft	Solid Shaft	
4.81	3760	1.72	II	03	2A10DA	364	1120	990	3.42-43
		2.46	III	03	2A12DB	364	1120	990	3.42-43
4.20	4555	0.84	-	03	2A100	417	1120	990	3.38-39
		1.14	I	03	2A105	417	1120	990	3.38-39
4.13	4380	1.72	II	03	2A10DA	424	1120	990	3.42-43
		2.11	III	03	2A12DB	424	1120	990	3.42-43
3.49	5180	1.71	II	03	2A10DA	501	1120	990	3.42-43
		1.72	II	03	2A12DA	501	1120	990	3.42-43
		1.79	II	03	2A12DB	501	1120	990	3.42-43
3.03	5970	1.48	II	03	2A10DA	578	1120	990	3.42-43
		1.55	II	03	2A12DA	578	1120	990	3.42-43
		1.72	II	03	2B12DA	578	2070	1640	3.42-43
		3.09	III	03	2B12DB	578	2070	1640	3.42-43
2.56	7070	1.25	I	03	2A10DA	683	1120	990	3.42-43
		1.31	I	03	2A12DA	683	1120	990	3.42-43
		1.72	II	03	2B12DA	683	2070	1640	3.42-43
		2.61	III	03	2B12DB	683	2070	1640	3.42-43
2.16	8375	1.06	I	03	2A10DA	809	1120	990	3.42-43
		1.11	I	03	2A12DA	809	1120	990	3.42-43
		1.72	II	03	2B12DA	809	2070	1640	3.42-43
		2.21	III	03	2B12DB	809	2070	1640	3.42-43
1.83	9885	0.94	-	03	2A12DA	956	1120	990	3.42-43
		1.72	II	03	2B12DA	956	2070	1640	3.42-43
		1.72	II	03	2B14DA	956	2070	1640	3.42-43
		1.87	II	03	2B14DB	956	2070	1640	3.42-43
1.57	11525	0.80	-	03	2A12DA	1117	1120	990	3.42-43
		1.60	II	03	2B12DA	1117	2070	1640	3.42-43
		1.60	II	03	2B14DA	1117	2070	1640	3.42-43
		3.20	III	03	2C14DB	1117	3480	2850	3.42-43
1.33	13600	1.35	I	03	2B12DA	1320	2070	1640	3.42-43
		1.35	I	03	2B14DA	1320	2070	1640	3.42-43
		1.72	II	03	2C14DA	1320	3480	2850	3.42-43
		2.70	III	03	2C14DB	1320	3480	2850	3.42-43
1.06	17070	1.08	I	03	2B12DA	1656	2070	1640	3.42-43
		1.08	I	03	2B14DA	1656	2070	1640	3.42-43
		1.72	II	03	2C14DA	1656	3480	2850	3.42-43
		2.16	III	03	2C14DB	1656	3480	2850	3.42-43
0.894	20240	1.1	I	03	2B14DA	1957	2070	1640	3.42-43
		1.72	II	03	2C14DA	1957	3480	2850	3.42-43
0.770	23500	1.57	II	03	2C14DA	2272	3480	2850	3.42-43
0.684	26450	1.39	I	03	2C14DA	2559	3480	2850	3.42-43
0.594	30460	1.21	I	03	2C14DA	2944	3480	2850	3.42-43
0.498	36330	1.02	I	03	2C14DA	3511	3480	2850	3.42-43

60 Hz, 1750 RPM Gearmotor Selection Tables

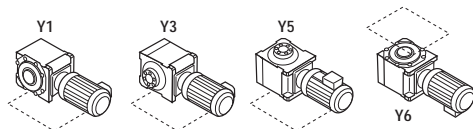

Horizontal Motor Shaft Y1, Y3, Y5, Y6 Mounting Positions

1/2 HP

Output Speed RPM	Output Torque in•lb	Service Factor		SELECTION			Overhung Load (lbs)		Dimension Page LHYM
		SF	AGMA Class	HP Symbol	Frame Size	Ratio	Hollow Shaft	Solid Shaft	
11.6	2500	2.70	III	05	2A105	151	1120	990	3.38-39
9.78	2964	1.40	II	05	2A100	179	1120	990	3.38-39
		2.08	III	05	2A105	179	1120	990	3.38-39
8.45	3430	1.38	I	05	2A100	207	1120	990	3.38-39
		1.90	II	05	2A105	207	1120	990	3.38-39
		2.30	III	05	2A110	207	1120	990	3.38-39
7.03	4123	1.16	I	05	2A100	249	1120	990	3.38-39
		1.50	II	05	2A105	249	1120	990	3.38-39
		2.04	III	05	2A115	249	1120	990	3.38-39
5.74	5050	1.16	I	05	2A100	305	1120	990	3.38-39
		1.52	II	05	2A105	305	1120	990	3.38-39
		2.54	III	05	2B120	305	2070	1640	3.38-39
4.81	5700	1.07	I	05	2A10DA	364	1120	990	3.42-43
		1.54	II	05	2A12DB	364	1120	990	3.42-43
		3.06	III	05	2B12DB	364	2070	1640	3.42-43
4.13	6635	1.07	I	05	2A10DA	424	1120	990	3.42-43
		1.32	I	05	2A12DB	424	1120	990	3.42-43
		2.62	III	05	2B12DB	424	2070	1640	3.42-43
3.49	7855	1.07	I	05	2A10DA	501	1120	990	3.42-43
		1.07	I	05	2A12DA	501	1120	990	3.42-43
		2.23	III	05	2B12DB	501	2070	1640	3.42-43
3.03	9050	1.07	I	05	2A12DA	578	2070	1640	3.42-43
		1.25	I	05	2A12DB	578	2070	1640	3.42-43
		2.08	III	05	2B12DB	578	2070	1640	3.42-43
2.56	10710	1.06	I	05	2A12DA	683	1120	990	3.42-43
		1.63	II	05	2B12DB	683	2070	1640	3.42-43
		2.11	III	05	2B14DB	683	2070	1640	3.42-43
		3.27	III	05	2C14DB	683	3480	2850	3.42-43
2.16	12690	1.07	I	05	2B12DA	809	2070	1640	3.42-43
		1.48	II	05	2B12DB	809	2070	1640	3.42-43
		2.76	III	05	2C14DB	809	3480	2850	3.42-43
1.83	14980	1.07	I	05	2B12DA	956	2070	1640	3.42-43
		1.51	II	05	2B14DB	956	2070	1640	3.42-43
		2.33	III	05	2C14DB	956	3480	2850	3.42-43
1.57	17460	1.00	I	05	2B12DA	1117	2070	1640	3.42-43
		1.29	I	05	2B14DB	1117	2070	1640	3.42-43
		2.00	III	05	2C14DB	1117	3480	2855	3.42-43
1.33	20610	1.07	I	05	2C14DA	1320	3480	2850	3.42-43
		1.69	II	05	2C14DB	1320	3480	2850	3.42-43
		2.18	III	05	2C16DA	1320	3480	2850	3.44-45
1.06	25860	1.07	I	05	2C14DA	1656	3480	2850	3.42-43
		1.74	II	05	2C16DA	1656	3480	2850	3.42-43
		2.26	III	05	2D16DA	1656	4810	3930	3.44-45

Gearmotors

Selection Tables

Gearmotor Selection Tables 60 Hz, 1750 RPM

Horizontal Motor Shaft Y1, Y3, Y5, Y6 Mounting Positions

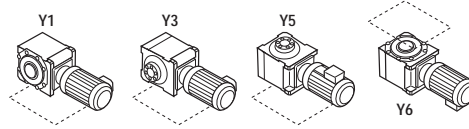

1/2 HP

Output Speed RPM	Output Torque in•lb	Service Factor		SELECTION			Overhung Load (lbs)		Dimension Page LHYM
		SF	AGMA Class	HP Symbol	Frame Size	Ratio	Hollow Shaft	Solid Shaft	
0.894	30660	1.07	I	05	2C14DA	1957	3480	2850	3.42-43
		1.91	II	05	2D16DA	1957	4810	3930	3.44-45
		1.93	II	05	2D17DA	1957	4810	3930	3.44-45
0.770	35600	1.65	II	05	2D16DA	2272	4810	3930	3.44-45
		1.67	II	05	2D17DA	2272	4810	3930	3.44-45
		2.22	III	05	2E17DA	2272	5170	4110	3.44-45
0.684	40080	1.46	II	05	2D16DA	2559	4810	3930	3.44-45
		1.48	II	05	2D17DA	2559	4810	3930	3.44-45
		1.97	II	05	2E17DB	2559	5170	4110	3.44-45
0.594	46150	1.27	I	05	2D16DA	2944	4810	3930	3.44-45
		1.71	II	05	2E17DA	2944	5170	4110	3.44-45
0.498	55050	1.07	I	05	2D16DB	3511	4810	3930	3.44-45
		1.08	I	05	2D17DA	3511	4810	3930	3.44-45
		1.43	II	05	2E17DA	3511	5170	4110	3.44-45
0.401	68370	1.15	I	05	2E17DA	4365	5170	4110	3.44-45
0.338	81100	0.97	-	05	2E17DA	5177	5170	4110	3.44-45

Gearmotors

Selection Tables

3/4 HP

Output Speed RPM	Output Torque in•lb	Service Factor		SELECTION			Overhung Load (lbs)		Dimension Page LHYM
		SF	AGMA Class	HP Symbol	Frame Size	Ratio	Hollow Shaft	Solid Shaft	
19.9	2185	2.26	III	08	2A105	88	1120	990	3.38-39
17.2	2528	2.16	III	08	2A105	102	1120	990	3.38-39
14.2	3062	2.14	III	08	2A105	123	1120	990	3.38-39
11.6	3748	1.40	II	08	2A100	151	1120	990	3.38-39
		2.32	III	08	2A110	151	1120	990	3.38-39
9.78	4446	1.00	I	08	2A100	179	1120	990	3.38-39
		1.38	I	08	2A105	179	1120	990	3.38-39
		1.67	II	08	2A110	179	1120	990	3.38-39
		2.13	III	08	2A125	179	1120	990	3.38-39
8.45	5146	1.29	I	08	2A105	207	1120	990	3.38-39
		1.53	II	08	2A110	207	1120	990	3.38-39
		2.32	III	08	2B120	207	2070	1640	3.38-39
7.03	6185	1.00	I	08	2A105	249	1120	990	3.38-39
		1.22	I	08	2A110	249	1120	990	3.38-39
		1.38	I	08	2A115	249	1120	990	3.38-39
		1.53	II	08	2A125	249	1120	990	3.38-39
		2.07	III	08	2B125	249	2070	1640	3.38-39
5.74	7576	1.01	I	08	2A105	305	1120	990	3.38-39
		1.27	I	08	2A115	305	1120	990	3.38-39
		1.69	II	08	2B120	305	2070	1640	3.38-39
		2.02	III	08	2B125	305	2070	1640	3.38-39

60 Hz, 1750 RPM Gearmotor Selection Tables

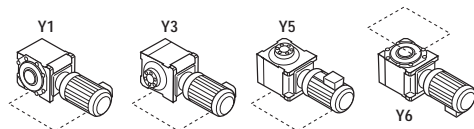

Horizontal Motor Shaft Y1, Y3, Y5, Y6 Mounting Positions

3/4 HP

Output Speed RPM	Output Torque in•lb	Service Factor		SELECTION			Overhung Load (lbs)		Dimension Page LHYM
		SF	AGMA Class	HP Symbol	Frame Size	Ratio	Hollow Shaft	Solid Shaft	
4.81	8550	1.12	I	08	2A12DB	364	1120	990	3.42-43
		2.23	III	08	2B12DB	364	2070	1640	3.42-43
4.13	9955	1.90	II	08	2B12DB	424	2070	1640	3.42-43
		1.91	II	08	2B14DB	424	2070	1640	3.42-43
3.49	11780	1.62	II	08	2B12DB	501	2070	1640	3.42-43
		1.62	II	08	2B14DB	501	2070	1640	3.42-43
		2.91	III	08	2C14DB	501	3480	2850	3.42-43
3.03	13570	1.40	II	08	2B12DB	578	2070	1640	3.42-43
		1.40	II	08	2B14DB	578	2070	1640	3.42-43
		2.81	III	08	2C14DB	578	3480	2850	3.42-43
2.56	16060	1.19	I	08	2B12DB	683	2070	1640	3.42-43
		1.19	I	08	2B14DB	683	2070	1640	3.42-43
		2.38	III	08	2C14DB	683	3480	2850	3.42-43
2.16	19040	1.00	I	08	2B12DB	809	2070	1640	3.42-43
		1.00	I	08	2B14DB	809	2070	1640	3.42-43
		2.01	III	08	2C14DB	809	3480	2850	3.42-43
1.83	22470	1.70	II	08	2C14DB	956	3480	2850	3.42-43
		1.70	II	08	2C16DA	956	3480	2850	3.42-43
		2.85	III	08	2D16DA	956	4810	3930	3.44-45
1.57	26190	1.45	II	08	2C14DB	1117	3480	2850	3.42-43
		2.44	III	08	2D16DA	1117	4810	3930	3.44-45
1.33	30920	1.23	I	08	2C14DB	1320	3480	2850	3.42-43
		2.06	III	08	2D16DA	1320	4810	3090	3.44-45
		2.08	III	08	2D17DA	1320	4810	3090	3.44-45
1.06	38795	1.64	II	08	2D16DA	1656	4810	3930	3.44-45
		1.66	II	08	2D17DA	1656	4810	3930	3.44-45
		2.21	III	08	2E17DA	1656	5170	4110	3.44-45
0.894	46000	1.39	I	08	2D16DA	1957	4810	3930	3.44-45
		1.41	II	08	2D17DA	1957	4810	3930	3.44-45
		1.87	II	08	2E17DA	1957	5170	4110	3.44-45
0.770	53400	1.20	I	08	2D16DA	2272	4810	3930	3.44-45
		1.21	I	08	2D17DA	2272	4810	3930	3.44-45
		1.61	II	08	2E17DA	2272	5170	4110	3.44-45
0.684	60120	1.06	I	08	2D16DA	2559	4810	3930	3.44-45
		1.08	I	08	2D17DA	2559	4810	3930	3.44-45
		1.43	II	08	2E17DA	2559	5170	4110	3.44-45
0.594	69230	1.24	I	08	2E17DA	2944	5170	4110	3.44-45
0.498	82580	1.04	I	08	2E17DA	3511	5170	4110	3.44-45

Gearmotors

Selection Tables

Gearmotor Selection Tables 60 Hz, 1750 RPM

Horizontal Motor Shaft Y1, Y3, Y5, Y6 Mounting Positions

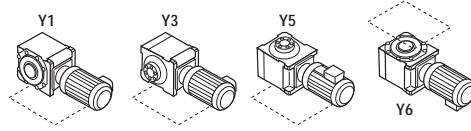

1 HP

Output Speed RPM	Output Torque in•lb	Service Factor		SELECTION			Overhung Load (lbs)		Dimension Page LHYM
		SF	AGMA Class	HP Symbol	Frame Size	Ratio	Hollow Shaft	Solid Shaft	
19.9	2913	1.69	II	1	2A100	88	1120	990	3.38-39
		2.23	III	1	2A105	88	1120	990	3.38-39
17.2	3371	1.61	II	1	2A100	102	1120	990	3.38-39
		2.12	III	1	2A105	102	1120	990	3.38-39
14.2	4083	1.30	I	1	2A100	123	1120	990	3.38-39
		1.60	II	1	2A105	123	1120	990	3.38-39
		2.01	III	1	2A110	123	1120	990	3.38-39
11.6	5000	1.04	I	1	2A100	151	1120	990	3.38-39
		1.44	II	1	2A105	151	1120	990	3.38-39
		2.56	III	1	2B120	151	2070	1640	3.38-39
9.78	5928	1.03	I	1	2A105	179	1120	990	3.38-39
		1.48	II	1	2A115	179	1120	990	3.38-39
		2.31	III	1	2B120	179	2070	1640	3.38-39
8.45	6861	1.15	I	1	2A110	207	1120	990	3.38-39
		1.73	II	1	2B120	207	2070	1640	3.38-39
		2.16	III	1	2B125	207	2070	1640	3.38-39
7.03	8243	1.01	I	1	2A115	249	1120	990	3.38-39
		1.60	II	1	2B125	249	2070	1640	3.38-39
		2.27	III	1	2B145	249	2070	1640	3.38-39
5.74	10101	1.26	I	1	2B120	305	2070	1640	3.38-39
		1.51	II	1	2B125	305	2070	1640	3.38-39
		1.85	II	1	2B145	305	2070	1640	3.38-39
4.81	11400	1.63	II	1	2B12DB	364	2070	1640	3.42-43
		1.63	II	1	2B14DB	364	2070	1640	3.42-43
		2.13	III	1	2C14DB	364	3480	2850	3.42-43
4.13	13275	1.40	II	1	2B12DB	424	2070	1640	3.42-43
		1.40	II	1	2B14DB	424	2070	1640	3.42-43
		2.13	III	1	2C14DB	424	3480	2850	3.42-43
3.49	15710	1.19	I	1	2B12DB	501	2070	1640	3.42-43
		1.19	I	1	2B14DB	501	2070	1640	3.42-43
		2.13	III	1	2C14DB	501	3480	2850	3.42-43
3.03	18100	1.03	I	1	2B12DB	578	2070	1640	3.42-43
		1.03	I	1	2B14DB	578	2070	1640	3.42-43
		2.06	III	1	2C14DB	578	3480	2850	3.42-43
2.56	21410	1.74	II	1	2C14DB	683	3480	2850	3.42-43
		1.74	II	1	2C16DA	683	3480	2850	3.42-43
		2.13	III	1	2D16DA	683	4810	3930	3.44-45
2.16	25380	1.47	II	1	2C14DB	809	3480	2850	3.42-43
		2.13	III	1	2D16DA	809	4810	3930	3.44-45
1.83	29960	1.24	I	1	2C14DB	956	3480	2850	3.42-43
		2.09	III	1	2D16DA	956	4810	3930	3.44-45
		2.13	III	1	2E17DA	956	5170	4110	3.44-45

Gearmotors
Selection Tables

60 Hz, 1750 RPM Gearmotor Selection Tables

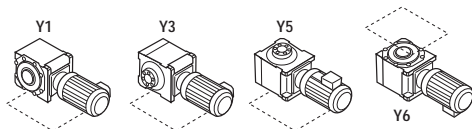

Horizontal Motor Shaft Y1, Y3, Y5, Y6 Mounting Positions

1 HP

Output Speed RPM	Output Torque in•lb	Service Factor		SELECTION			Overhung Load (lbs)		Dimension Page LHYM
		SF	AGMA Class	HP Symbol	Frame Size	Ratio	Hollow Shaft	Solid Shaft	
1.57	34925	1.07	I	1	2C14DB	1117	3480	2850	3.42-43
		1.07	I	1	2C16DA	1117	3480	2850	3.42-43
		1.79	II	1	2D16DA	1117	4810	3930	3.44-45
		1.81	II	1	2D17DA	1117	4810	3930	3.44-45
1.33	41225	1.51	II	1	2D16DA	1320	4810	3930	3.44-45
		1.53	II	1	2D17DA	1320	4810	3930	3.44-45
		2.03	III	1	2E17DA	1320	5170	4110	3.44-45
1.06	51725	1.21	I	1	2D16DA	1656	4810	3930	3.44-45
		1.62	II	1	2E17DA	1656	5170	4110	3.44-45
0.894	61330	1.02	I	1	2D16DA	1957	4810	3930	3.44-45
		1.03	I	1	2D17DA	1957	4810	3930	3.44-45
0.770	71210	1.18	I	1	2E17DA	2272	5170	4110	3.44-45
0.684	80160	1.05	I	1	2E17DA	2559	5170	4110	3.44-45

1.5 HP

Output Speed RPM	Output Torque in•lb	Service Factor		SELECTION			Overhung Load (lbs)		Dimension Page LHYM		
		SF	AGMA Class	HP Symbol	Frame Size	Ratio	Hollow Shaft	Solid Shaft			
159	547	2.10	III	1H	2A100	11	1120	990	3.38-39		
97.2	895	2.10	III	1H	2A100	18	1120	990	3.38-39		
83.3	1044	2.10	III	1H	2A100	21	1120	990	3.38-39		
62.5	1390	2.10	III	1H	2A100	28	1120	990	3.38-39		
44.9	1937	2.10	III	1H	2A100	39	1120	990	3.38-39		
		38.0	2290	2.10	III	1H	2A100	46	1120	990	3.38-39
		33.0	2635	2.10	III	1H	2A100	53	1120	990	3.38-39
29.2	2980	1.74	II	1H	2A100	60	1120	990	3.38-39		
		2.24	III	1H	2A105	60	1120	990	3.38-39		
23.6	3685	1.75	II	1H	2A100	74	1120	990	3.38-39		
		2.13	III	1H	2A105	74	1120	990	3.38-39		
19.9	4370	1.15	I	1H	2A100	88	1120	990	3.38-39		
		1.52	II	1H	2A105	88	1120	990	3.38-39		
		2.17	III	1H	2A125	88	1120	990	3.38-39		
17.2	5055	1.10	I	1H	2A100	102	1120	990	3.38-39		
		1.42	II	1H	2A105	102	1120	990	3.38-39		
		2.67	III	1H	2B120	102	2070	1640	3.38-39		
14.2	6125	1.09	I	1H	2A105	123	1120	990	3.38-39		
		1.57	II	1H	2A115	123	1120	990	3.38-39		
		2.22	III	1H	2B120	123	2070	1640	3.38-39		
11.6	7500	1.16	I	1H	2A110	151	1120	990	3.38-39		
		1.70	II	1H	2B120	151	2070	1640	3.38-39		
		2.13	III	1H	2B125	151	2070	1640	3.38-39		

Gearmotors

Selection Tables

Gearmotor Selection Tables 60 Hz, 1750 RPM

Horizontal Motor Shaft

Y1, Y3, Y5, Y6 Mounting Positions

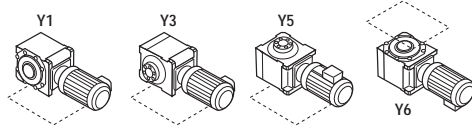

1.5 HP

Output Speed RPM	Output Torque in•lb	Service Factor		SELECTION			Overhung Load (lbs)		Dimension Page LHYM
		SF	AGMA Class	HP Symbol	Frame Size	Ratio	Hollow Shaft	Solid Shaft	
9.78	8890	1.06	I	1H	2A125	179	1120	990	3.38-39
		1.56	II	1H	2B120	179	2070	1640	3.38-39
		2.04	III	1H	2B125	179	2070	1640	3.38-39
8.45	10295	1.18	I	1H	2B120	207	2070	1640	3.38-39
		1.47	II	1H	2B125	207	2070	1640	3.38-39
		2.64	III	1H	2C140	207	3480	2850	3.40-41
7.03	12370	1.09	I	1H	2B125	249	2070	1640	3.38-39
		1.55	II	1H	2B145	249	2070	1640	3.38-39
		2.17	III	1H	2C140	249	3480	2850	3.40-41
5.74	15150	1.01	I	1H	2B125	305	2070	1640	3.38-39
		1.26	I	1H	2B145	305	2070	1640	3.38-39
		1.77	II	1H	2C140	305	3480	2850	3.40-41
		2.25	III	1H	2C145	305	3480	2850	3.40-41
4.81	17100	1.11	I	1H	2B12DB	364	2070	1640	3.42-43
		1.11	I	1H	2B14DB	364	2070	1640	3.42-43
		1.45	II	1H	2C14DB	364	3480	2850	3.42-43
		2.23	III	1H	2C14DC	364	3480	2850	3.42-43
4.13	19910	1.45	II	1H	2C14DB	424	3480	2850	3.42-43
		1.91	II	1H	2C14DC	424	3480	2850	3.42-43
		1.91	II	1H	2C16DB	424	3480	2850	3.42-43
3.49	23560	1.45	II	1H	2C14DB	501	3480	2850	3.42-43
		1.62	II	1H	2C16DB	501	3480	2850	3.42-43
		2.72	III	1H	2D16DB	501	4810	3930	3.44-45
3.03	27140	1.40	II	1H	2C14DB	578	3480	2850	3.42-43
		1.40	II	1H	2C16DA	578	3480	2850	3.42-43
		2.36	III	1H	2D16DB	578	4810	3930	3.44-45
2.56	32125	1.19	I	1H	2C14DB	683	3480	2850	3.42-43
		1.45	II	1H	2D16DA	683	4810	3930	3.44-45
		1.99	II	1H	2D16DB	683	4810	3930	3.44-45
		2.02	III	1H	2D17DB	683	4810	3930	3.44-45
2.16	38075	1.00	I	1H	2C14DB	809	3480	2850	3.42-43
		1.00	I	1H	2C16DA	809	3480	2850	3.42-43
		1.45	II	1H	2D16DA	809	4810	3930	3.44-45
		1.70	II	1H	2D17DB	809	4810	3930	3.44-45
		2.26	III	1H	2E17DB	809	5170	4110	3.44-45
1.83	44940	1.42	II	1H	2D16DA	956	4810	3930	3.44-45
		1.44	II	1H	2D17DA	956	4810	3930	3.44-45
		1.92	II	1H	2E17DB	956	5170	4110	3.44-45
1.57	52385	1.22	I	1H	2D16DA	1117	4810	3930	3.44-45
		1.45	II	1H	2E17DA	1117	5170	4110	3.44-45
1.33	61840	1.03	I	1H	2D16DA	1320	4810	3930	3.44-45
		1.04	I	1H	2D17DA	1320	4810	3930	3.44-45
1.06	77590	1.11	I	1H	2E17DA	1656	5170	4110	3.44-45
0.894	92000	0.94	-	1H	2E17DA	1957	5170	4110	3.44-45

Gearmotors Selection Tables

60 Hz, 1750 RPM Gearmotor Selection Tables

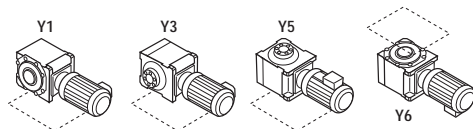

Horizontal Motor Shaft Y1, Y3, Y5, Y6 Mounting Positions

2 HP

Output Speed RPM	Output Torque in•lb	Service Factor		SELECTION			Overhung Load (lbs)		Dimension Page LHYM
		SF	AGMA Class	HP Symbol	Frame Size	Ratio	Hollow Shaft	Solid Shaft	
159	730	1.57	II	2	2A100	11	1120	990	3.38-39
		2.12	III	2	2A105	11	1120	990	3.38-39
97.2	1190	1.57	II	2	2A100	18	1120	990	3.38-39
		2.12	III	2	2A105	18	1120	990	3.38-39
83.3	1390	1.57	II	2	2A100	21	1120	990	3.38-39
		2.12	III	2	2A105	21	1120	990	3.38-39
62.5	1855	1.57	II	2	2A100	28	1120	990	3.38-39
		2.12	III	2	2A105	28	1120	990	3.38-39
45.0	2580	1.57	II	2	2A100	39	1120	990	3.38-39
		2.12	III	2	2A105	39	1120	990	3.38-39
38.0	3050	1.57	II	2	2A100	46	1120	990	3.38-39
		2.12	III	2	2A105	46	1120	990	3.38-39
33.0	3515	1.57	II	2	2A100	53	1120	990	3.38-39
		2.12	III	2	2A105	53	1120	990	3.38-39
29.2	3970	1.33	I	2	2A100	60	1120	990	3.38-39
		1.64	II	2	2A105	60	1120	990	3.38-39
		2.13	III	2	2A110	60	1120	990	3.38-39
23.6	4910	1.29	I	2	2A100	74	1120	990	3.38-39
		1.56	II	2	2A105	74	1120	990	3.38-39
		2.66	III	2	2B120	74	2070	1640	3.38-39
19.9	5830	1.11	I	2	2A105	88	1120	990	3.38-39
		1.48	II	2	2A115	88	1120	990	3.38-39
		2.07	III	2	2B120	88	2070	1640	3.38-39
17.2	6740	1.06	I	2	2A105	102	1120	990	3.38-39
		1.40	II	2	2A115	102	1120	990	3.38-39
		2.00	III	2	2B120	102	2070	1640	3.38-39
14.2	8165	1.00	I	2	2A110	123	1120	990	3.38-39
		1.66	II	2	2B120	123	2070	1640	3.38-39
		2.12	III	2	2B125	123	2070	1640	3.38-39
11.6	10000	1.27	I	2	2B120	151	2070	1640	3.38-39
		1.59	II	2	2B125	151	2070	1640	3.38-39
		2.64	III	2	2C140	151	3480	2850	3.38-39
9.78	11860	1.15	I	2	2B120	179	2070	1640	3.38-39
		1.53	II	2	2B125	179	2070	1640	3.38-39
		2.30	III	2	2C140	179	3480	2850	3.40-41
8.45	13725	1.08	I	2	2B125	207	2070	1640	3.38-39
		1.98	II	2	2C140	207	3480	2850	3.40-41
		2.43	III	2	2C145	207	3480	2850	3.40-41
7.03	16495	1.13	I	2	2B145	249	2070	1640	3.38-39
		1.62	II	2	2C140	249	3480	2850	3.40-41
		2.02	III	2	2C145	249	3480	2850	3.40-41
5.74	20200	1.33	I	2	2C140	305	3480	2850	3.40-41
		1.54	II	2	2C145	305	3480	2850	3.40-41
		2.33	III	2	2D160	305	4810	3930	3.40-41

Gearmotors

Selection Tables

Gearmotor Selection Tables 60 Hz, 1750 RPM

Horizontal Motor Shaft Y1, Y3, Y5, Y6 Mounting Positions

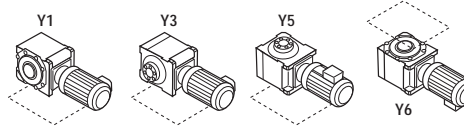

2 HP

Output Speed RPM	Output Torque in•lb	Service Factor		SELECTION			Overhung Load (lbs)		Dimension Page LHYM
		SF	AGMA Class	HP Symbol	Frame Size	Ratio	Hollow Shaft	Solid Shaft	
4.81	22800	1.07	I	2	2C14DB	364	3480	2850	3.42-43
		1.63	II	2	2C14DC	364	3480	2850	3.42-43
		1.63	II	2	2C16DB	364	3480	2850	3.42-43
		2.24	III	2	2D16DB	364	4810	3930	3.44-45
4.13	26550	1.07	I	2	2C14DB	424	3480	2850	3.42-43
		1.40	II	2	2C16DB	424	3480	2850	3.42-43
		2.24	III	2	2D16DB	424	4810	3930	3.44-45
3.49	31420	1.07	I	2	2C14DB	501	3480	2850	3.42-43
		1.99	II	2	2D16DB	501	4810	3930	3.44-45
		2.02	III	2	2D17DB	501	4810	3930	3.44-45
3.03	36190	1.03	I	2	2C14DB	578	3480	2850	3.42-43
		1.03	I	2	2C16DA	578	3480	2850	3.42-43
		1.73	II	2	2D16DB	578	4810	3930	3.44-45
		1.75	II	2	2D17DB	578	4810	3930	3.44-45
2.56	42835	1.07	I	2	2D16DA	683	4810	3930	3.44-45
		1.48	II	2	2D17DB	683	4810	3930	3.44-45
		1.97	II	2	2E17DB	683	5170	4110	3.44-45
2.16	50770	1.07	I	2	2D16DA	809	4810	3930	3.44-45
		1.66	II	2	2E17DB	809	5170	4110	3.44-45
1.83	59925	1.04	I	2	2D16DA	956	4810	3930	3.44-45
		1.06	I	2	2D17DA	956	4810	3930	3.44-45
		1.40	II	2	2E17DB	956	5170	4110	3.44-45
1.57	69850	1.07	I	2	2E17DA	1117	5170	4110	3.44-45
1.33	82450	1.02	I	2	2E17DA	1320	5170	4110	3.44-45

Gearmotors

Selection Tables

3 HP

Output Speed RPM	Output Torque in•lb	Service Factor		SELECTION			Overhung Load (lbs)		Dimension Page LHYM
		SF	AGMA Class	HP Symbol	Frame Size	Ratio	Hollow Shaft	Solid Shaft	
159	1095	1.07	I	3	2A100	11	1120	990	3.38-39
		1.42	II	3	2A105	11	1120	990	3.38-39
		2.27	III	3	2A120	11	1120	990	3.38-39
97.2	1790	1.07	I	3	2A100	18	1120	990	3.38-39
		1.45	II	3	2A105	18	1120	990	3.38-39
		2.27	III	3	2A120	18	1120	990	3.38-39
83.3	2090	1.07	I	3	2A100	21	1120	990	3.38-39
		1.42	II	3	2A105	21	1120	990	3.38-39
		1.61	II	3	2A110	21	1120	990	3.38-39
		2.27	III	3	2A120	21	1120	990	3.38-39
62.5	2780	1.07	I	3	2A100	28	1120	990	3.38-39
		1.42	II	3	2A105	28	1120	990	3.38-39
		1.58	II	3	2A110	28	1120	990	3.38-39
		2.27	III	3	2A120	28	1120	990	3.38-39

60 Hz, 1750 RPM Gearmotor Selection Tables

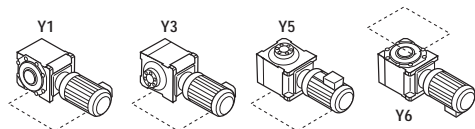

Horizontal Motor Shaft Y1, Y3, Y5, Y6 Mounting Positions

3 HP

Output Speed RPM	Output Torque in•lb	Service Factor		SELECTION			Overhung Load (lbs)		Dimension Page LHYM
		SF	AGMA Class	HP Symbol	Frame Size	Ratio	Hollow Shaft	Solid Shaft	
44.9	3875	1.07	I	3	2A100	39	1120	990	3.38-39
		1.42	II	3	2A105	39	1120	990	3.38-39
		1.58	II	3	2A110	39	1120	990	3.38-39
		2.27	III	3	2A120	39	1120	990	3.38-39
38.0	4575	1.07	I	3	2A100	46	1120	990	3.38-39
		1.42	II	3	2A105	46	1120	990	3.38-39
		1.58	II	3	2A110	46	1120	990	3.38-39
		2.09	III	3	2A125	46	1120	990	3.38-39
33.0	5270	1.07	I	3	2A100	53	1120	990	3.38-39
		1.42	II	3	2A105	53	1120	990	3.38-39
		1.58	II	3	2A110	53	1120	990	3.38-39
		2.27	III	3	2B120	53	2070	1640	3.38-39
29.2	5955	1.10	I	3	2A105	60	1120	990	3.38-39
		1.42	II	3	2A110	60	1120	990	3.38-39
		1.62	II	3	2A115	60	1120	990	3.38-39
		2.27	III	3	2B120	60	2070	1640	3.38-39
23.6	7370	1.05	I	3	2A105	74	1120	990	3.38-39
		1.77	II	3	2B120	74	2070	1640	3.38-39
		2.18	III	3	2B125	74	2070	1640	3.38-39
19.9	8740	1.08	I	3	2A125	88	1120	990	3.38-39
		1.77	II	3	2B125	88	2070	1640	3.38-39
		2.16	III	3	2B145	88	2070	1640	3.38-39
17.2	10110	1.33	I	3	2B120	102	2070	1640	3.38-39
		1.71	II	3	2B125	102	2070	1640	3.38-39
		2.66	III	3	2C140	102	3480	2850	3.40-41
14.2	12250	1.13	I	3	2B120	123	2070	1640	3.38-39
		1.42	II	3	2B125	123	2070	1640	3.38-39
		2.33	III	3	2C140	123	3480	2850	3.40-41
11.6	14995	1.08	I	3	2B125	151	2070	1640	3.38-39
		1.76	II	3	2C140	151	3480	2850	3.40-41
		2.45	III	3	2C145	151	3480	2850	3.40-41
9.78	17785	1.04	I	3	2B125	179	2070	1640	3.38-39
		1.08	I	3	2B145	179	2070	1640	3.38-39
		1.56	II	3	2C140	179	3480	2850	3.40-41
		1.92	II	3	2C145	179	3480	2850	3.40-41
		2.12	III	3	2C165	179	3480	2850	3.40-41
8.45	20585	1.32	I	3	2C140	207	3480	2850	3.40-41
		1.55	II	3	2C145	207	3480	2850	3.40-41
		2.57	III	3	2D165	207	4810	3930	3.40-41
7.03	24740	1.08	I	3	2C140	249	3480	2850	3.40-41
		1.55	II	3	2C165	249	3480	2850	3.40-41
		2.52	III	3	2D160	249	4810	3930	3.40-41

Gearmotors

Selection Tables

Gearmotor Selection Tables 60 Hz, 1750 RPM

Horizontal Motor Shaft Y1, Y3, Y5, Y6 Mounting Positions

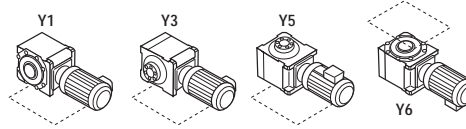

3 HP

Output Speed RPM	Output Torque in•lb	Service Factor		SELECTION			Overhung Load (lbs)		Dimension Page LHYM
		SF	AGMA Class	HP Symbol	Frame Size	Ratio	Hollow Shaft	Solid Shaft	
5.74	30300	1.11	I	3	2C145	305	3480	2850	3.40-41
		1.58	II	3	2D160	305	4810	3930	3.40-41
		1.77	II	3	2D165	305	4810	3930	3.40-41
4.81	34200	1.11	I	3	2C14DC	364	3480	2850	3.42-43
		1.53	II	3	2D16DB	364	4810	3930	3.44-45
		1.89	II	3	2D17DC	364	4810	3930	3.44-45
4.13	39830	0.96	-	3	2C14DC	424	3480	2850	3.42-43
		1.53	II	3	2D16DB	424	4810	3930	3.44-45
		1.62	II	3	2D17DC	424	4810	3930	3.44-45
		2.16	III	3	2E17DC	424	5170	4110	3.44-45
3.49	47130	0.81	-	3	2C16DB	501	3480	2850	3.42-43
		1.36	I	3	2D16DB	501	4810	3930	3.44-45
		1.37	I	3	2D17DB	501	4810	3930	3.44-45
		1.83	II	3	2E17DC	501	5170	4110	3.44-45
3.03	54285	1.18	I	3	2D16DB	578	4810	3930	3.44-45
		1.19	I	3	2D17DB	578	4810	3930	3.44-45
		1.53	II	3	2E17DB	578	5170	4110	3.44-45
2.56	64255	1.00	I	3	2D16DB	683	4810	3930	3.44-45
		1.01	I	3	2D17DB	683	4810	3930	3.44-45
2.16	76155	1.01	I	3	2D17DB	809	4810	3930	3.44-45
		1.24	I	3	2E17DB	809	5170	4110	3.44-45
1.83	89885	1.05	I	3	2E17DB	956	5170	4110	3.44-45

Gearmotors
Selection Tables

5 HP

Output Speed RPM	Output Torque in•lb	Service Factor		SELECTION			Overhung Load (lbs)		Dimension Page LHYM
		SF	AGMA Class	HP Symbol	Frame Size	Ratio	Hollow Shaft	Solid Shaft	
159	1820	1.37	I	5	2A120	11	1120	990	3.38-39
		1.56	II	5	2A125	11	1120	990	3.38-39
97.2	2980	1.37	I	5	2A120	18	1120	990	3.38-39
		1.56	II	5	2A125	18	1120	990	3.38-39
		2.96	III	5	2A145	18	1120	990	3.38-39
83.3	3480	1.06	I	5	2A115	21	1120	990	3.38-39
		1.56	II	5	2A125	21	1120	990	3.38-39
		2.46	III	5	2A145	21	1120	990	3.38-39
62.5	4635	1.06	I	5	2A115	28	1120	990	3.38-39
		1.86	II	5	2A125	28	1120	990	3.38-39
		2.02	III	5	2A145	28	1120	990	3.38-39
44.9	6455	1.06	I	5	2A115	39	1120	990	3.38-39
		1.37	I	5	2A120	39	1120	990	3.38-39
		1.48	II	5	2A125	39	1120	990	3.38-39
		2.96	III	5	2B145	39	2070	1640	3.38-39

60 Hz, 1750 RPM Gearmotor Selection Tables

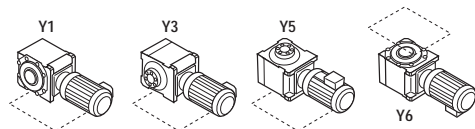
Horizontal Motor Shaft
Y1, Y3, Y5, Y6 Mounting Positions

5 HP

Output Speed RPM	Output Torque in•lb	Service Factor		SELECTION			Overhung Load (lbs)		Dimension Page LHYM
		SF	AGMA Class	HP Symbol	Frame Size	Ratio	Hollow Shaft	Solid Shaft	
38.0	7630	1.05	I	5	2A115	46	1120	990	3.38-39
		1.37	I	5	2B120	46	2070	1640	3.38-39
		1.60	II	5	2B125	46	2070	1640	3.38-39
		2.51	III	5	2B145	46	2070	1640	3.38-39
33.0	8785	1.05	I	5	2A115	53	1120	990	3.38-39
		1.58	II	5	2B125	53	2070	1640	3.38-39
		2.18	III	5	2B145	53	2070	1640	3.38-39
29.2	9930	1.36	I	5	2B120	60	2070	1640	3.38-39
		1.53	II	5	2B125	60	2070	1640	3.38-39
		2.70	III	5	2C140	60	3480	2850	3.40-41
23.6	12285	1.06	I	5	2B120	74	2070	1640	3.38-39
		1.56	II	5	2B145	74	2070	1640	3.38-39
		2.32	III	5	2C140	74	3480	2850	3.40-41
19.9	14570	1.07	I	5	2B125	88	2070	1640	3.38-39
		1.85	II	5	2C140	88	3480	2850	3.40-41
		2.14	III	5	2C145	88	3480	2850	3.40-41
17.2	16855	1.02	I	5	2B125	102	2070	1640	3.38-39
		1.13	I	5	2B145	102	2070	1640	3.38-39
		1.61	II	5	2C140	102	3480	2850	3.40-41
		2.04	III	5	2C145	102	3480	2850	3.40-41
14.2	20415	1.39	I	5	2C140	123	3480	2850	3.40-41
		1.85	II	5	2C145	123	3480	2850	3.40-41
		2.60	III	5	2D160	123	4810	3930	3.40-41
11.6	24990	1.05	I	5	2C140	151	3480	2850	3.40-41
		1.44	II	5	2C145	151	3480	2850	3.40-41
		2.00	III	5	2D160	151	4810	3930	3.40-41
9.78	29640	1.14	I	5	2C145	179	3480	2850	3.40-41
		1.55	II	5	2D160	179	4810	3930	3.40-41
		2.04	III	5	2D165	179	4810	3930	3.40-41
8.45	34310	1.11	I	5	2C165	207	3480	2850	3.40-41
		1.55	II	5	2D165	207	4810	3930	3.40-41
		2.22	III	5	2E175	207	5170	4110	3.40-41
7.03	41240	1.51	II	5	2D165	249	4810	3930	3.40-41
		1.93	II	5	2E175	249	5170	4110	3.40-41
5.74	50510	1.05	I	5	2D165	305	4810	3930	3.40-41
		1.52	II	5	2E175	305	5170	4110	3.40-41
4.81	57000	1.11	I	5	2D16DC	364	4810	3930	3.44-45
		1.12	I	5	2D17DC	364	4810	3930	3.44-45
		1.49	II	5	2E17DC	364	5170	4110	3.44-45
4.13	66380	0.97	-	5	2D17DC	424	4810	3930	3.44-45
		1.28	I	5	2E17DC	424	5170	4110	3.44-45
3.49	78550	0.82	-	5	2D17DC	501	4810	3930	3.44-45
		1.09	I	5	2E17DC	501	5170	4110	3.44-45
3.03	90480	0.94	-	5	2E17DC	578	5170	4110	3.44-45

Gearmotors

Selection
Tables

Gearmotor Selection Tables 60 Hz, 1750 RPM

Horizontal Motor Shaft Y1, Y3, Y5, Y6 Mounting Positions

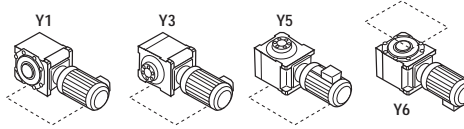

7.5 HP

Output Speed RPM	Output Torque in•lb	Service Factor		SELECTION			Overhung Load (lbs)		Dimension Page LHYM
		SF	AGMA Class	HP Symbol	Frame Size	Ratio	Hollow Shaft	Solid Shaft	
159	2735	1.06	I	8	2A125	11	1120	990	3.38-39
		2.32	III	8	2A140	11	1120	990	3.38-39
97.2	4475	1.06	I	8	2A125	18	1120	990	3.38-39
		1.97	II	8	2A145	18	1120	990	3.38-39
		2.32	III	8	2B140	18	2070	1640	3.38-39
83.3	5220	1.06	I	8	2A125	21	1120	990	3.38-39
		1.67	II	8	2A145	21	1120	990	3.38-39
		2.32	III	8	2B140	21	2070	1640	3.38-39
62.5	6960	1.26	I	8	2A125	28	1120	990	3.38-39
		1.36	I	8	2A145	28	1120	990	3.38-39
		2.32	III	8	2B140	28	2070	1640	3.38-39
44.9	9685	1.06	I	8	2B125	39	2070	1640	3.38-39
		1.97	II	8	2B145	39	2070	1640	3.38-39
		2.32	III	8	2C140	39	3480	2850	3.40-41
38.0	11445	1.08	I	8	2B125	46	2070	1640	3.38-39
		1.69	II	8	2B145	46	2070	1640	3.38-39
		2.32	III	8	2C140	46	3480	2850	3.40-41
33.0	13175	1.08	I	8	2B125	53	2070	1640	3.38-39
		1.44	II	8	2B145	53	2070	1640	3.38-39
		2.14	III	8	2C140	53	3480	2850	3.40-41
29.2	14890	1.03	I	8	2B125	60	2070	1640	3.38-39
		1.81	II	8	2C140	60	3480	2850	3.40-41
		2.18	III	8	2C145	60	3480	2850	3.40-41
23.6	18425	1.03	I	8	2B145	74	2070	1640	3.38-39
		1.57	II	8	2C140	74	3480	2850	3.40-41
		1.97	II	8	2C145	74	3480	2850	3.40-41
		2.05	III	8	2C165	74	3480	2850	3.40-41
19.9	21850	1.25	I	8	2C140	88	3480	2850	3.40-41
		1.41	II	8	2C145	88	3480	2850	3.40-41
		2.70	III	8	2D165	88	4810	3930	3.40-41
17.2	25280	1.08	I	8	2C140	102	3480	2850	3.40-41
		1.37	I	8	2C145	102	3480	2850	3.40-41
		1.49	II	8	2C165	102	3480	2850	3.40-41
		2.53	III	8	2D175	102	4810	3930	3.40-41
14.2	30625	1.23	I	8	2C145	123	3480	2850	3.40-41
		1.73	II	8	2D160	123	4810	3930	3.40-41
		2.04	III	8	2D165	123	4810	3930	3.40-41
11.6	37490	1.02	I	8	2C165	151	3480	2850	3.40-41
		1.41	II	8	2D165	151	4810	3930	3.40-41
		1.70	II	8	2D175	151	4810	3930	3.40-41
		2.02	III	8	2E175	151	5170	4110	3.40-41

Gearmotors

Selection Tables

60 Hz, 1750 RPM Gearmotor Selection Tables

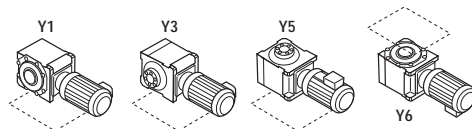

Horizontal Motor Shaft Y1, Y3, Y5, Y6 Mounting Positions

7.5 HP

Output Speed RPM	Output Torque in•lb	Service Factor		SELECTION			Overhung Load (lbs)		Dimension Page LHYM
		SF	AGMA Class	HP Symbol	Frame Size	Ratio	Hollow Shaft	Solid Shaft	
9.78	44465	1.02	I	8	2D160	179	4810	3930	3.40-41
		1.44	II	8	2D175	179	4810	3930	3.40-41
		1.92	II	8	2E175	179	5170	4110	3.40-41
8.45	51465	1.05	I	8	2D165	207	4810	3930	3.40-41
		1.48	II	8	2E175	207	5170	4110	3.40-41
7.03	61860	1.03	I	8	2D165	249	4810	3930	3.40-41
		1.27	I	8	2E175	249	5170	4110	3.40-41
5.74	75760	1.02	I	8	2E175	305	5170	4110	3.40-41
4.81	85500	1.01	I	8	2E17DC	364	5170	4110	3.44-45

10 HP

Output Speed RPM	Output Torque in•lb	Service Factor		SELECTION			Overhung Load (lbs)		Dimension Page LHYM
		SF	AGMA Class	HP Symbol	Frame Size	Ratio	Hollow Shaft	Solid Shaft	
159	3645	1.73	II	10	2A140	11	1120	990	3.38-39
		2.00	III	10	2A145	11	1120	990	3.38-39
97.2	5965	1.47	II	10	2A145	18	1120	990	3.38-39
		2.01	III	10	2B145	18	2070	1640	3.38-39
83.3	6960	1.22	I	10	2A145	21	1120	990	3.38-39
		1.73	II	10	2B140	21	2070	1640	3.38-39
		2.01	III	10	2B145	21	2070	1640	3.38-39
62.5	9275	1.00	I	10	2A145	28	1120	990	3.38-39
		1.73	II	10	2B140	28	2070	1640	3.38-39
		2.00	III	10	2B145	28	2070	1640	3.38-39
44.9	12910	1.47	II	10	2B145	39	2070	1640	3.38-39
		1.73	II	10	2C140	39	3480	2850	3.40-41
		2.01	III	10	2C145	39	3480	2850	3.40-41
38.0	15255	1.24	I	10	2B145	46	2070	1640	3.38-39
		1.73	II	10	2C140	46	3480	2850	3.40-41
		2.01	III	10	2C145	46	3480	2850	3.40-41
33.0	17570	1.07	I	10	2B145	53	2070	1640	3.38-39
		1.60	II	10	2C140	53	3480	2850	3.40-41
		2.16	III	10	2C165	53	3480	2850	3.40-41
29.2	19855	1.35	I	10	2C140	60	3480	2850	3.40-41
		1.60	II	10	2C145	60	3480	2850	3.40-41
		2.52	III	10	2D165	60	4810	3930	3.40-41
23.6	24570	1.16	I	10	2C140	74	3480	2820	3.40-41
		1.48	II	10	2C145	74	3480	2850	3.40-41
		2.15	III	10	2D165	74	4810	3930	3.40-41
19.9	29140	1.05	I	10	2C145	88	3480	2850	3.40-41
		2.01	III	10	2D165	88	4810	3930	3.40-41

Gearmotors

Selection Tables

Gearmotor Selection Tables 60 Hz, 1750 RPM

Horizontal Motor Shaft Y1, Y3, Y5, Y6 Mounting Positions

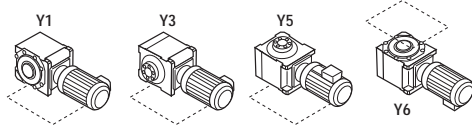

10 HP

Output Speed RPM	Output Torque in•lb	Service Factor		SELECTION			Overhung Load (lbs)		Dimension Page LHYM
		SF	AGMA Class	HP Symbol	Frame Size	Ratio	Hollow Shaft	Solid Shaft	
17.2	33710	1.00	I	10	2C145	102	3480	2850	3.40-41
		1.41	II	10	2D160	102	4810	3930	3.40-41
		2.14	III	10	2E175	102	5170	4110	3.40-41
14.2	40830	1.30	I	10	2D160	123	4810	3930	3.40-41
		1.53	II	10	2D165	123	4810	3930	3.40-41
		2.01	III	10	2E175	123	5170	4110	3.40-41
11.6	49985	1.00	I	10	2D160	151	4810	3930	3.40-41
		1.52	II	10	2E175	151	5170	4110	3.40-41
9.78	59285	1.00	I	10	2D165	179	4810	3930	3.40-41
		1.07	I	10	2D175	179	4810	3930	3.40-41
		1.44	II	10	2E175	179	5170	4110	3.40-41
8.45	68620	1.11	I	10	2E175	207	5170	4110	3.40-41

15 HP

Output Speed RPM	Output Torque in•lb	Service Factor		SELECTION			Overhung Load (lbs)		Dimension Page LHYM
		SF	AGMA Class	HP Symbol	Frame Size	Ratio	Hollow Shaft	Solid Shaft	
159	5470	1.18	I	15	2A140	11	1120	990	3.38-39
		1.36	I	15	2A145	11	1120	990	3.38-39
97.2	8950	1.16	I	15	2B140	18	2070	1640	3.38-39
		1.37	I	15	2B145	18	2070	1640	3.38-39
		1.81	II	15	2B160	18	2070	1640	3.38-39
		1.18	I	15	2B140	21	2070	1640	3.38-39
83.3	10440	1.37	I	15	2B145	21	2070	1640	3.38-39
		1.68	II	15	2B165	21	2070	1640	3.38-39
		2.15	III	15	2C165	21	3480	2850	3.40-41
62.5	13910	1.16	I	15	2B140	28	2070	1640	3.38-39
		1.76	II	15	2C160	28	3480	2850	3.40-41
		2.15	III	15	2C165	28	3480	2850	3.40-41
44.9	19370	1.16	I	15	2C140	39	3480	2850	3.40-41
		1.76	II	15	2C160	39	3480	2850	3.40-41
		2.15	III	15	2C165	39	3480	2850	3.40-41
38.0	22880	1.16	I	15	2C140	46	3480	2850	3.40-41
		1.37	I	15	2C145	46	3480	2850	3.40-41
		1.66	II	15	2C165	46	3480	2850	3.40-41
		2.02	III	15	2D165	46	4810	3930	3.40-41
33.0	26355	1.09	I	15	2C140	53	3480	2850	3.40-41
		1.33	I	15	2C145	53	3480	2850	3.40-41
		1.44	II	15	2C165	53	3480	2850	3.40-41
		2.00	III	15	2D165	53	4810	3930	3.40-41

60 Hz, 1750 RPM Gearmotor Selection Tables

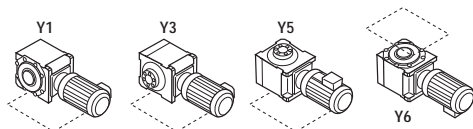

Horizontal Motor Shaft Y1, Y3, Y5, Y6 Mounting Positions

15 HP

Output Speed RPM	Output Torque in•lb	Service Factor		SELECTION			Overhung Load (lbs)		Dimension Page LHYM
		SF	AGMA Class	HP Symbol	Frame Size	Ratio	Hollow Shaft	Solid Shaft	
29.2	29785	1.09	I	15	2C145	60	3480	2850	3.40-41
		1.71	II	15	2D165	60	4810	3930	3.40-41
		2.15	III	15	2D175	60	4810	3930	3.40-41
23.6	36850	1.05	I	15	2C165	74	3480	2850	3.40-41
		1.46	II	15	2D165	74	4810	3930	3.40-41
		1.96	II	15	2D175	74	4810	3930	3.40-41
19.9	43700	1.34	I	15	2D165	88	4810	3930	3.40-41
		1.41	II	15	2D170	88	4810	3930	3.40-41
		1.68	II	15	2E175	88	5170	4110	3.40-41
17.2	50565	1.26	I	15	2D175	102	4810	3930	3.40-41
		1.42	II	15	2E175	102	5170	4110	3.40-41
14.2	61250	1.02	I	15	2D165	123	4810	3930	3.40-41
		1.06	I	15	2D175	123	4810	3930	3.40-41
		1.34	I	15	2E175	123	5170	4110	3.40-41
11.6	74975	1.03	I	15	2E175	151	5170	4110	3.40-41

Gearmotors

Selection Tables

20 HP

Output Speed RPM	Output Torque in•lb	Service Factor		SELECTION			Overhung Load (lbs)		Dimension Page LHYM
		SF	AGMA Class	HP Symbol	Frame Size	Ratio	Hollow Shaft	Solid Shaft	
159	7290	1.00	I	20	2A145	11	1120	990	3.38-39
		1.47	II	20	2B165	11	2070	1640	3.38-39
		2.01	III	20	2C175	11	3480	2850	3.40-41
97.2	11930	1.01	I	20	2B145	18	2070	1640	3.38-39
		1.47	II	20	2B165	18	2070	1640	3.38-39
		2.01	III	20	2C175	18	3480	2850	3.40-41
83.3	13920	1.01	I	20	2B145	21	2070	1640	3.38-39
		1.35	I	20	2C160	21	3480	2850	3.40-41
		1.60	II	20	2C165	21	3480	2850	3.40-41
		2.01	III	20	2C175	21	3480	2850	3.40-41
62.5	18555	1.00	I	20	2B145	28	2070	1640	3.38-39
		1.31	I	20	2C160	28	3480	2850	3.40-41
		1.61	II	20	2C165	28	3480	2850	3.40-41
		2.01	III	20	2C175	28	3480	2850	3.40-41
44.9	25825	1.01	I	20	2C145	39	3480	2850	3.40-41
		1.42	II	20	2C165	39	3480	2850	3.40-41
		1.61	II	20	2D165	39	4810	3930	3.40-41
		2.01	III	20	2D175	39	4810	3930	3.40-41
38.0	30515	1.01	I	20	2C145	46	3480	2850	3.40-41
		1.51	II	20	2D165	46	4810	3930	3.40-41
		2.00	III	20	2D175	46	4810	3930	3.40-41

Gearmotor Selection Tables 60 Hz, 1750 RPM

Horizontal Motor Shaft Y1, Y3, Y5, Y6 Mounting Positions

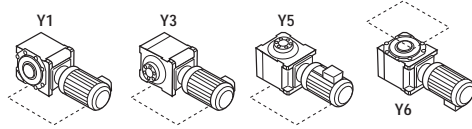

20 HP

Output Speed RPM	Output Torque in•lb	Service Factor		SELECTION			Overhung Load (lbs)		Dimension Page LHYM
		SF	AGMA Class	HP Symbol	Frame Size	Ratio	Hollow Shaft	Solid Shaft	
33.0	35140	1.07	I	20	2C165	53	3480	2850	3.40-41
		1.51	II	20	2D165	53	4810	3930	3.40-41
		1.70	II	20	2D170	53	4810	3930	3.40-41
		2.01	III	20	2E175	53	5170	4110	3.40-41
29.2	39700	1.25	I	20	2D165	60	4810	3930	3.40-41
		1.31	I	20	2D170	60	4810	3930	3.40-41
		1.61	II	20	2D175	60	4810	3930	3.40-41
23.6	49100	1.07	I	20	2D165	74	4810	3930	3.40-41
		1.47	II	20	2E175	74	5170	4110	3.40-41
19.9	58275	1.01	I	20	2D165	88	4810	3930	3.40-41
		1.24	I	20	2E175	88	5170	4110	3.40-41
17.2	67400	1.07	I	20	2E175	102	5170	4110	3.40-41

25 HP

Output Speed RPM	Output Torque in•lb	Service Factor		SELECTION			Overhung Load (lbs)		Dimension Page LHYM
		SF	AGMA Class	HP Symbol	Frame Size	Ratio	Hollow Shaft	Solid Shaft	
159	9100	1.08	I	25	2B160	11	2070	1640	3.38-39
		1.49	II	25	2C170	11	3480	2850	3.40-41
		1.61	II	25	2C175	11	3480	2850	3.40-41
97.2	14900	1.08	I	25	2B160	18	2070	1640	3.38-39
		1.48	II	25	2C170	18	3480	2850	3.40-41
83.3	17400	1.08	I	25	2C160	21	3480	2850	3.40-41
		1.48	II	25	2C170	21	3480	2850	3.40-41
62.5	23190	1.06	I	25	2C160	28	3480	2850	3.40-41
		1.30	I	25	2C165	28	3480	2850	3.40-41
		1.48	II	25	2C170	28	3480	2850	3.40-41
44.9	32285	1.05	I	25	2C160	39	3480	2850	3.40-41
		1.30	I	25	2D165	39	4810	3930	3.40-41
		1.48	II	25	2D170	39	4810	3930	3.40-41
38.0	38145	1.05	I	25	2D160	46	4810	3930	3.40-41
		1.46	II	25	2D170	46	4810	3930	3.40-41
33.0	43900	1.00	I	25	2D160	53	4810	3930	3.40-41
		1.48	II	25	2D175	53	4810	3930	3.40-41
		1.62	II	25	2E175	53	5170	4110	3.40-41
29.2	49600	1.02	I	25	2D165	60	4810	3930	3.40-41
		1.29	I	25	2D175	60	4810	3930	3.40-41
23.6	61400	1.05	I	25	2D175	74	4810	3930	3.40-41

60 Hz, 1750 RPM Gearmotor Selection Tables

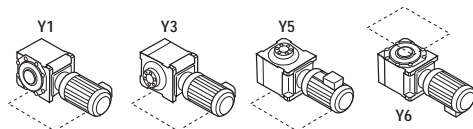

Horizontal Motor Shaft Y1, Y3, Y5, Y6 Mounting Positions

30 HP

Output Speed RPM	Output Torque in•lb	Service Factor		SELECTION			Overhung Load (lbs)		Dimension Page LHYM
		SF	AGMA Class	HP Symbol	Frame Size	Ratio	Hollow Shaft	Solid Shaft	
159	10900	1.34	I	30	2C175	11	3480	2850	3.40-41
97.2	17850	1.34	I	30	2C175	18	3480	2850	3.40-41
83.3	20880	1.10	I	30	2C165	21	3480	2850	3.40-41
		1.34	I	30	2C175	21	3480	2850	3.40-41
62.5	27800	1.10	I	30	2C165	28	3480	2850	3.40-41
		1.34	I	30	2C175	28	3480	2850	3.40-41
44.9	38700	1.08	I	30	2D165	39	4810	3930	3.40-41
		1.34	I	30	2D175	39	4810	3930	3.40-41
38.0	45700	1.01	I	30	2D165	46	4810	3930	3.40-41
		1.34	I	30	2D175	46	4810	3930	3.40-41
33.0	52700	1.00	I	30	2D165	53	4810	3930	3.40-41
		1.36	I	30	2E175	53	5170	4110	3.40-41
29.2	59500	1.10	I	30	2D175	60	4810	3930	3.40-41

Gearmotors

Selection Tables

40 HP

Output Speed RPM	Output Torque in•lb	Service Factor		SELECTION			Overhung Load (lbs)		Dimension Page LHYM
		SF	AGMA Class	HP Symbol	Frame Size	Ratio	Hollow Shaft	Solid Shaft	
159	14500	1.00	I	40	2C175	11	3480	2850	3.40-41
97.2	23800	1.00	I	40	2C175	18	3480	2850	3.40-41
83.3	27800	1.00	I	40	2C175	21	3480	2850	3.40-41
62.5	37100	1.00	I	40	2C175	28	3480	2850	3.40-41
44.9	51600	1.00	I	40	2D175	39	4810	3930	3.40-41
38.0	61000	1.00	I	40	2D175	46	4810	3930	3.40-41
33.0	70200	1.00	I	40	2E175	53	5170	4110	3.40-41

Gearmotor Selection Tables 60 Hz, 1750 RPM

Vertical Motor Shaft Y2, Y4 Mounting Positions

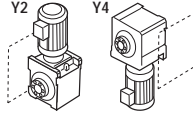

1/4 HP

Output Speed RPM	Output Torque in•lb	Service Factor		SELECTION			Overhung Load (lbs)		Dimension Page LHYM
		SF	AGMA Class	HP Symbol	Frame Size	Ratio	Hollow Shaft	Solid Shaft	
8.45	1714	2.76	III	02	2A100	207	1120	990	3.38–39
7.03	2062	2.32	III	02	2A100	249	1120	990	3.38–39
5.74	2525	2.32	III	02	2A100	305	1120	990	3.38–39

1/3 HP

Output Speed RPM	Output Torque in•lb	Service Factor		SELECTION			Overhung Load (lbs)		Dimension Page LHYM
		SF	AGMA Class	HP Symbol	Frame Size	Ratio	Hollow Shaft	Solid Shaft	
9.78	1956	2.27	III	03	2A100	179	1120	990	3.38–39
8.45	2264	2.09	III	03	2A100	207	1120	990	3.38–39
7.03	2722	1.75	II	03	2A100	249	1120	990	3.38–39
		2.27	III	03	2A105	249	1120	990	3.38–39
5.74	3334	1.75	II	03	2A100	305	1120	990	3.38–39
		2.30	III	03	2A105	305	1120	990	3.38–39

1/2 HP

Output Speed RPM	Output Torque in•lb	Service Factor		SELECTION			Overhung Load (lbs)		Dimension Page LHYM
		SF	AGMA Class	HP Symbol	Frame Size	Ratio	Hollow Shaft	Solid Shaft	
11.6	2499	2.10	III	05	2A100	151	1120	990	3.38–39
9.78	2964	1.50	II	05	2A100	179	1120	990	3.38–39
		2.10	III	05	2A105	179	1120	990	3.38–39
8.45	3431	1.38	I	05	2A100	207	1120	990	3.38–39
		1.90	II	05	2A105	207	1120	990	3.38–39
		2.30	III	05	2A110	207	1120	990	3.38–39
7.03	4124	1.16	I	05	2A100	249	1120	990	3.38–39
		1.50	II	05	2A105	249	1120	990	3.38–39
		2.04	III	05	2A115	249	1120	990	3.38–39
5.74	5051	1.16	I	05	2A100	305	1120	990	3.38–39
		1.52	II	05	2A105	305	1120	990	3.38–39
		2.54	III	05	2B120	305	2070	1640	3.38–39

60 Hz, 1750 RPM Gearmotor Selection Tables

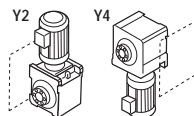

Vertical Motor Shaft Y2, Y4 Mounting Positions

3/4 HP

Output Speed RPM	Output Torque in•lb	Service Factor		SELECTION			Overhung Load (lbs)		Dimension Page LHYM
		SF	AGMA Class	HP Symbol	Frame Size	Ratio	Hollow Shaft	Solid Shaft	
19.9	2185	2.26	III	08	2A100	88	1120	990	3.38-39
17.2	2528	2.16	III	08	2A100	102	1120	990	3.38-39
14.3	3041	1.75	II	08	2A100	123	1120	990	3.38-39
		2.14	III	08	2A105	123	1120	990	3.38-39
11.6	3749	1.40	II	08	2A100	151	1120	990	3.38-39
		2.32	III	08	2A110	151	1120	990	3.38-39
9.78	4447	1.00	I	08	2A100	179	1120	990	3.38-39
		1.69	II	08	2A110	179	1120	990	3.38-39
		2.13	III	08	2A125	179	1120	990	3.38-39
8.45	5146	1.27	I	08	2A105	207	1120	990	3.38-39
		1.53	II	08	2A110	207	1120	990	3.38-39
		2.32	III	08	2B120	207	2070	1640	3.38-39
7.03	6186	1.00	I	08	2A105	249	1120	990	3.38-39
		1.53	II	08	2A125	249	1120	990	3.38-39
		2.14	III	08	2B125	249	2070	1640	3.38-39
5.74	7576	1.01	I	08	2A105	305	1120	990	3.38-39
		1.69	II	08	2B120	305	2070	1640	3.38-39
		2.02	III	08	2B125	305	2070	1640	3.38-39

1 HP

Output Speed RPM	Output Torque in•lb	Service Factor		SELECTION			Overhung Load (lbs)		Dimension Page LHYM
		SF	AGMA Class	HP Symbol	Frame Size	Ratio	Hollow Shaft	Solid Shaft	
19.9	2914	1.70	II	1	2A100	88	1120	990	3.38-39
		2.24	III	1	2A105	88	1120	990	3.38-39
17.2	3371	1.62	II	1	2A100	102	1120	990	3.38-39
		2.13	III	1	2A105	102	1120	990	3.38-39
14.2	4083	1.31	I	1	2A100	123	1120	990	3.38-39
		1.61	II	1	2A105	123	1120	990	3.38-39
11.6	4999	2.01	III	1	2A110	123	1120	990	3.38-39
		1.05	I	1	2A100	151	1120	990	3.38-39
9.78	5929	1.45	II	1	2A105	151	1120	990	3.38-39
		2.56	III	1	2B120	151	1120	990	3.38-39
		1.04	I	1	2A105	179	1120	990	3.38-39
8.45	6862	1.49	II	1	2A115	179	1120	990	3.38-39
		2.31	III	1	2B120	179	2070	1640	3.38-39
		1.15	I	1	2A110	207	1120	990	3.38-39
7.03	8248	1.74	II	1	2B120	207	2070	1640	3.38-39
		2.17	III	1	2B125	207	2070	1640	3.38-39
		1.02	I	1	2A115	249	1120	990	3.38-39
5.74	10102	1.61	II	1	2B125	249	2070	1640	3.38-39
		2.04	III	1	2B145	249	2070	1640	3.38-39
		1.27	I	1	2B120	305	2070	1640	3.38-39
		1.52	II	1	2B125	305	2070	1640	3.38-39
		1.86	II	1	2B145	305	2070	1640	3.38-39

Gearmotors

Selection Tables

Gearmotor Selection Tables 60 Hz, 1750 RPM

Vertical Motor Shaft Y2, Y4 Mounting Positions

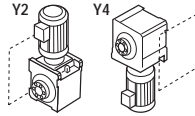

1.5 HP

Output Speed RPM	Output Torque in•lb	Service Factor		SELECTION			Overhung Load (lbs)		Dimension Page LHYM
		SF	AGMA Class	HP Symbol	Frame Size	Ratio	Hollow Shaft	Solid Shaft	
159	547	2.10	III	1H*	2A100	11	1120	990	3.38-39
97.2	895	2.10	III	1H*	2A100	18	1120	990	3.38-39
83.3	1044	2.10	III	1H	2A100	21	1120	990	3.38-39
62.5	1392	2.10	III	1H	2A100	28	1120	990	3.38-39
44.9	1937	2.10	III	1H	2A100	39	1120	990	3.38-39
38.0	2289	2.10	III	1H	2A100	46	1120	990	3.38-39
33.0	2636	2.10	III	1H	2A100	53	1120	990	3.38-39
29.2	2979	1.78	II	1H	2A100	60	1120	990	3.38-39
		2.20	III	1H	2A105	60	1120	990	3.38-39
23.6	3685	1.72	II	1H	2A100	74	1120	990	3.38-39
		2.09	III	1H	2A105	74	1120	990	3.38-39
19.9	4371	1.13	I	1H	2A100	88	1120	990	3.38-39
		1.49	II	1H	2A105	88	1120	990	3.38-39
		2.17	III	1H	2A125	88	1120	990	3.38-39
17.2	5057	1.08	I	1H	2A100	102	1120	990	3.38-39
		1.42	II	1H	2A105	102	1120	990	3.38-39
		2.67	III	1H	2B120	102	2070	1640	3.38-39
14.2	6125	1.07	I	1H	2A105	123	1120	990	3.38-39
		1.55	II	1H	2A115	123	1120	990	3.38-39
		2.22	III	1H	2B120	123	2070	1640	3.38-39
11.6	7498	1.16	I	1H	2A110	151	1120	990	3.38-39
		1.70	II	1H	2B120	151	2070	1640	3.38-39
		2.13	III	1H	2B125	151	2070	1640	3.38-39
9.78	8893	1.06	I	1H	2A125	179	1120	990	3.38-39
		1.54	II	1H	2B120	179	2070	1640	3.38-39
		2.04	III	1H	2B125	179	2070	1640	3.38-39
8.45	10293	1.16	I	1H	2B120	207	2070	1640	3.38-39
		1.44	II	1H	2B125	207	2070	1640	3.38-39
		1.83	II	1H	2B145	207	2070	1640	3.38-39
7.03	12372	1.07	I	1H	2B125	249	2070	1640	3.38-39
		1.52	II	1H	2B165	249	2070	1640	3.38-39
		1.98	II	1H	2C165	249	3480	2850	3.40-41
5.74	15152	1.01	I	1H	2B125	305	2070	1640	3.38-39
		1.24	I	1H	2B145	305	2070	1640	3.38-39
		1.36	I	1H	2C145	305	3480	2850	3.40-41

* These Models are not available for Y4 Mounting Position

60 Hz, 1750 RPM Gearmotor Selection Tables

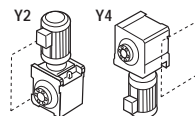
Vertical Motor Shaft
Y2, Y4 Mounting Positions

2 HP

Output Speed RPM	Output Torque in•lb	Service Factor		SELECTION			Overhung Load (lbs)		Dimension Page LHYM
		SF	AGMA Class	HP Symbol	Frame Size	Ratio	Hollow Shaft	Solid Shaft	
159	729	1.57	II	2*	2A100	11	1120	990	3.38-39
		2.13	III	2*	2A105	11	1120	990	3.38-39
97.2	1193	1.57	II	2*	2A100	18	1120	990	3.38-39
		2.13	III	2*	2A105	18	1120	990	3.38-39
83.3	1392	1.57	II	2	2A100	21	1120	990	3.38-39
		2.13	III	2	2A105	21	1120	990	3.38-39
62.5	1855	1.57	II	2	2A100	28	1120	990	3.38-39
		2.13	III	2	2A105	28	1120	990	3.38-39
44.9	2583	1.57	II	2	2A100	39	1120	990	3.38-39
		2.13	III	2	2A105	39	1120	990	3.38-39
38.0	3052	1.57	II	2	2A100	46	1120	990	3.38-39
		2.13	III	2	2A105	46	1120	990	3.38-39
33.0	3514	1.57	II	2	2A100	53	1120	990	3.38-39
		2.13	III	2	2A105	53	1120	990	3.38-39
29.2	3971	1.33	I	2	2A100	60	1120	990	3.38-39
		1.65	II	2	2A105	60	1120	990	3.38-39
		2.13	III	2	2A110	60	1120	990	3.38-39
23.6	4914	1.29	I	2	2A100	74	1120	990	3.38-39
		1.57	II	2	2A105	74	1120	990	3.38-39
		2.65	III	2	2B120	74	2070	1640	3.38-39
19.9	5827	1.12	I	2	2A105	88	1120	990	3.38-39
		1.49	II	2	2A115	88	1120	990	3.38-39
		2.07	III	2	2B120	88	2070	1640	3.38-39
17.2	6742	1.06	I	2	2A105	102	1120	990	3.38-39
		1.40	II	2	2A115	102	1120	990	3.38-39
		2.00	III	2	2B120	102	2070	1640	3.38-39
14.2	8167	1.00	I	2	2A110	123	1120	990	3.38-39
		1.67	II	2	2B120	123	2070	1640	3.38-39
		2.13	III	2	2B125	123	2070	1640	3.38-39
11.6	9997	1.28	I	2	2B120	151	2070	1640	3.38-39
		1.59	II	2	2B125	151	2070	1640	3.38-39
		2.51	III	2	2C165	151	3480	2850	3.40-41
9.78	11857	1.15	I	2	2B120	179	2070	1640	3.38-39
		1.53	II	2	2B125	179	2070	1640	3.38-39
		2.51	III	2	2C165	179	3480	2850	3.40-41
8.45	13724	1.08	I	2	2B125	207	2070	1640	3.38-39
		1.49	II	2	2C145	207	3480	2850	3.40-41
		2.51	III	2	2C165	207	3480	2850	3.40-41
7.03	16496	1.02	I	2	2B145	249	2070	1640	3.38-39
		1.49	II	2	2C165	249	3480	2850	3.40-41
5.74	20203	1.02	I	2	2C145	305	3480	2850	3.40-41
		1.49	II	2	2C165	305	3480	2850	3.40-41

* These Models are not available for Y4 Mounting Position

Gearmotor Selection Tables 60 Hz, 1750 RPM

Vertical Motor Shaft Y2, Y4 Mounting Positions

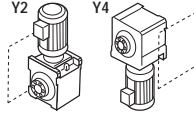

3 HP

Output Speed RPM	Output Torque in•lb	Service Factor		SELECTION			Overhung Load (lbs)		Dimension Page LHYM
		SF	AGMA Class	HP Symbol	Frame Size	Ratio	Hollow Shaft	Solid Shaft	
159	1094	1.05	I	3*	2A100	11	1120	990	3.38-39
		1.42	II	3*	2A105	11	1120	990	3.38-39
		2.26	III	3*	2A120	11	1120	990	3.38-39
97.2	1790	1.05	I	3*	2A100	18	1120	990	3.38-39
		1.42	II	3*	2A105	18	1120	990	3.38-39
		2.26	III	3*	2A120	18	1120	990	3.38-39
83.3	2088	1.05	I	3	2A100	21	1120	990	3.38-39
		1.42	II	3	2A105	21	1120	990	3.38-39
		2.26	III	3	2A120	21	1120	990	3.38-39
62.5	2783	1.05	I	3	2A100	28	1120	990	3.38-39
		1.42	II	3	2A105	28	1120	990	3.38-39
		2.26	III	3	2A120	28	1120	990	3.38-39
44.9	3874	1.05	I	3	2A100	39	1120	990	3.38-39
		1.42	II	3	2A105	39	1120	990	3.38-39
		2.26	III	3	2A120	39	1120	990	3.38-39
38.0	4578	1.05	I	3	2A100	46	1120	990	3.38-39
		1.42	II	3	2A105	46	1120	990	3.38-39
		2.08	III	3	2A125	46	1120	990	3.38-39
33.0	5271	1.05	I	3	2A100	53	1120	990	3.38-39
		1.42	II	3	2A105	53	1120	990	3.38-39
		2.26	III	3	2B120	53	2070	1640	3.38-39
29.2	5957	1.10	I	3	2A105	60	1120	990	3.38-39
		1.42	II	3	2A110	60	1120	990	3.38-39
		2.26	III	3	2B120	60	2070	1640	3.38-39
23.6	7371	1.04	I	3	2A105	74	1120	990	3.38-39
		1.77	II	3	2B120	74	2070	1640	3.38-39
		2.18	III	3	2B125	74	2070	1640	3.38-39
19.9	8741	1.08	I	3	2A125	88	1120	990	3.38-39
		1.77	II	3	2B125	88	2070	1640	3.38-39
		2.16	III	3	2B145	88	2070	1640	3.38-39
17.2	10113	1.33	I	3	2B120	102	2070	1640	3.38-39
		1.68	II	3	2B125	102	2070	1640	3.38-39
		1.86	II	3	2B165	102	2070	1640	3.38-39
14.2	12250	1.11	I	3	2B120	123	2070	1640	3.38-39
		1.42	II	3	2B125	123	2070	1640	3.38-39
		1.67	II	3	2C145	123	3480	2850	3.40-41
11.6	14996	1.06	I	3	2B125	151	2070	1640	3.38-39
		1.67	II	3	2C165	151	3480	2850	3.40-41
9.78	17786	1.02	I	3	2B125	179	2070	1640	3.38-39
		1.67	II	3	2C165	179	3480	2850	3.40-41
8.45	20586	1.67	II	3	2C165	207	3480	2850	3.40-41

* These Models are not available for Y4 Mounting Position

60 Hz, 1750 RPM Gearmotor Selection Tables

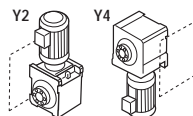
Vertical Motor Shaft
Y2, Y4 Mounting Positions

5 HP

Output Speed RPM	Output Torque in•lb	Service Factor		SELECTION			Overhung Load (lbs)		Dimension Page LHYM
		SF	AGMA Class	HP Symbol	Frame Size	Ratio	Hollow Shaft	Solid Shaft	
159	1823	1.36	I	5*	2A120	11	1120	990	3.38-39
		1.55	II	5*	2A125	11	1120	990	3.38-39
		2.54	III	5*	2A140	11	1120	990	3.38-39
97.2	2983	1.36	I	5*	2A120	18	1120	990	3.38-39
		1.55	II	5*	2A125	18	1120	990	3.38-39
		2.54	III	5*	2A140	18	1120	990	3.38-39
83.3	3480	1.05	I	5	2A115	21	1120	990	3.38-39
		1.86	II	5	2A125	21	1120	990	3.38-39
		2.46	III	5	2A145	21	1120	990	3.38-39
62.5	4639	1.05	I	5	2A115	28	1120	990	3.38-39
		1.86	II	5	2A125	28	1120	990	3.38-39
		2.02	III	5	2A145	28	1120	990	3.38-39
44.9	6457	1.05	I	5	2A115	39	1120	990	3.38-39
		1.58	II	5	2A125	39	1120	990	3.38-39
		2.94	III	5	2B145	39	2070	1640	3.38-39
38.0	7629	1.04	I	5	2A115	46	1120	990	3.38-39
		1.58	II	5	2B125	46	2070	1640	3.38-39
		2.04	III	5	2B145	46	2070	1640	3.38-39
33.0	8785	1.05	I	5	2A115	53	1120	990	3.38-39
		1.58	II	5	2B125	53	2070	1640	3.38-39
		2.18	III	5	2B145	53	2070	1640	3.38-39
29.2	9929	1.36	I	5	2B120	60	2070	1640	3.38-39
		1.51	II	5	2B125	60	2070	1640	3.38-39
		2.98	III	5	2C165	60	3480	2850	3.40-41
23.6	12285	1.06	I	5	2B120	74	2070	1640	3.38-39
		1.51	II	5	2B125	74	2070	1640	3.38-39
		2.04	III	5	2C165	74	3480	2850	3.40-41
19.9	14569	1.06	I	5	2B125	88	2070	1640	3.38-39
		1.49	II	5	2C145	88	3480	2850	3.40-41
		2.04	III	5	2C165	88	3480	2850	3.40-41
17.2	16856	1.01	I	5	2B125	102	2070	1640	3.38-39
		2.04	III	5	2C165	102	3480	2850	3.40-41
14.2	20417	1.00	I	5	2C145	123	3480	2850	3.40-41
		1.85	II	5	2C165	123	3480	2850	3.40-41
		2.04	III	5	2D165	123	4810	3930	3.40-41
11.6	24993	1.00	I	5	2C165	151	3480	2850	3.40-41
		1.50	II	5	2C175	151	3480	2850	3.40-41
		2.04	III	5	2D175	151	4810	3930	3.40-41
9.78	29644	1.00	I	5	2C165	179	3480	2850	3.40-41
		1.49	II	5	2D175	179	4810	3930	3.40-41
8.45	34309	1.00	I	5	2C165	207	3480	2850	3.40-41
		1.49	II	5	2D175	207	4810	3930	3.40-41
7.03	41240	1.00	I	5	2D175	249	4810	3930	3.40-41
5.74	50508	1.00	I	5	2D175	305	4810	3930	3.40-41

* These Models are not available for Y4 Mounting Position

Gearmotor Selection Tables 60 Hz, 1750 RPM

Vertical Motor Shaft Y2, Y4 Mounting Positions

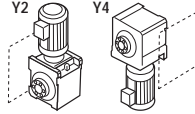

7.5 HP

Output Speed RPM	Output Torque in•lb	Service Factor		SELECTION			Overhung Load (lbs)		Dimension Page LHYM
		SF	AGMA Class	HP Symbol	Frame Size	Ratio	Hollow Shaft	Solid Shaft	
159	2735	1.03	I	8*	2A125	11	1120	990	3.38-39
		1.69	II	8*	2A140	11	1120	990	3.38-39
		2.25	III	8*	2B160	11	2070	1640	3.38-39
97.2	4474	1.03	I	8*	2A125	18	1120	990	3.38-39
		1.69	II	8*	2A140	18	1120	990	3.38-39
		2.25	III	8*	2B160	18	2070	1640	3.38-39
83.3	5221	1.03	I	8	2A125	21	1120	990	3.38-39
		1.64	II	8	2A145	21	1120	990	3.38-39
62.5	6958	1.24	I	8	2A125	28	1120	990	3.38-39
		1.98	II	8	2B145	28	2070	1640	3.38-39
		2.68	III	8	2B165	28	2070	1640	3.38-39
44.9	9685	1.05	I	8	2B125	39	2070	1640	3.38-39
		1.96	II	8	2B145	39	2070	1640	3.38-39
		2.72	III	8	2C165	39	3480	2850	3.40-41
38.0	11444	1.05	I	8	2B125	46	2070	1640	3.38-39
		1.66	II	8	2B165	46	2070	1640	3.38-39
33.0	13178	1.05	I	8	2B125	53	2070	1640	3.38-39
		1.44	II	8	2B165	53	2070	1640	3.38-39
		2.14	III	8	2C175	53	3480	2850	3.40-41
29.2	14893	1.01	I	8	2B125	60	2070	1640	3.38-39
		1.98	II	8	2C165	60	3480	2850	3.40-41
23.6	18427	1.02	I	8	2B165	74	2070	1640	3.38-39
		1.73	II	8	2C175	74	3480	2850	3.40-41
19.9	21853	1.36	I	8	2C165	88	3480	2850	3.40-41
		1.73	II	8	2C175	88	3480	2850	3.40-41
17.2	25283	1.36	I	8	2C165	102	3480	2850	3.40-41
		1.49	II	8	2C175	102	3480	2850	3.40-41
		1.98	II	8	2D175	102	4810	3930	3.40-41
14.2	30625	1.23	I	8	2C165	123	3480	2850	3.40-41
		1.36	I	8	2D165	123	4810	3930	3.40-41
11.6	37489	1.00	I	8	2C175	151	3480	2850	3.40-41
		1.36	I	8	2D175	151	4810	3930	3.40-41

* These Models are not available for Y4 Mounting Position

60 Hz, 1750 RPM Gearmotor Selection Tables

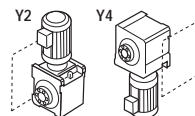

Vertical Motor Shaft Y2, Y4 Mounting Positions

10 HP

Output Speed RPM	Output Torque in•lb	Service Factor		SELECTION			Overhung Load (lbs)		Dimension Page LHYM
		SF	AGMA Class	HP Symbol	Frame Size	Ratio	Hollow Shaft	Solid Shaft	
159	3647	1.27	I	10*	2A140	11	1120	990	3.38-39
		1.48	II	10*	2A145	11	1120	990	3.38-39
		2.01	III	10*	2B165	11	2070	1640	3.38-39
97.2	5965	1.27	I	10*	2A140	18	1120	990	3.38-39
		1.48	II	10*	2A145	18	1120	990	3.38-39
		2.01	III	10*	2B165	18	2070	1640	3.38-39
83.3	6961	1.23	I	10	2A145	21	1120	990	3.38-39
		1.49	II	10	2B145	21	2070	1640	3.38-39
62.5	9277	1.01	I	10	2A145	28	1120	990	3.38-39
		1.49	II	10	2B145	28	2070	1640	3.38-39
		2.01	III	10	2B165	28	2070	1640	3.38-39
44.9	12914	1.47	II	10	2B145	39	2070	1640	3.38-39
		2.04	III	10	2C165	39	3480	2850	3.40-41
38.0	15259	1.02	I	10	2B145	46	2070	1640	3.38-39
		1.49	II	10	2C165	46	3480	2850	3.40-41
		2.49	III	10	2C175	46	3480	2850	3.40-41
33.0	17571	1.02	I	10	2B145	53	2070	1640	3.38-39
		1.49	II	10	2C165	53	3480	2850	3.40-41
29.2	19857	1.49	II	10	2C165	60	3480	2850	3.40-41
23.6	24569	1.02	I	10	2C165	74	3480	2850	3.40-41
19.9	29137	1.02	I	10	2C165	88	3480	2850	3.40-41
		1.49	II	10	2D175	88	4810	3930	3.40-41
17.2	33711	1.02	I	10	2C165	102	3480	2850	3.40-41
		1.49	II	10	2D175	102	4810	3930	3.40-41
14.2	40833	1.02	I	10	2D165	123	4810	3930	3.40-41
11.6	49985	1.02	I	10	2D175	151	4810	3930	3.40-41

Gearmotors

Selection Tables

15 HP

Output Speed RPM	Output Torque in•lb	Service Factor		SELECTION			Overhung Load (lbs)		Dimension Page LHYM
		SF	AGMA Class	HP Symbol	Frame Size	Ratio	Hollow Shaft	Solid Shaft	
159	5470	1.12	I	15*	2B160	11	2070	1640	3.38-39
		1.80	II	15*	2C170	11	3480	2850	3.40-41
97.2	8948	1.12	I	15*	2B160	18	2070	1640	3.38-39
		1.80	II	15*	2C170	18	3480	2850	3.40-41
62.5	13916	1.34	I	15	2B165	28	2070	1640	3.38-39
44.9	19371	1.36	I	15	2C165	39	3480	2850	3.40-41
38.0	22888	1.66	II	15	2C175	46	3480	2850	3.40-41
33.0	26356	1.07	I	15	2C175	53	3480	2850	3.40-41

* These Models are not available for Y4 Mounting Position

Gearmotor Selection Tables 60 Hz, 1750 RPM

Vertical Motor Shaft Y2, Y4 Mounting Positions

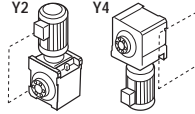

20 HP

Output Speed RPM	Output Torque in•lb	Service Factor		SELECTION			Overhung Load (lbs)		Dimension Page LHYM
		SF	AGMA Class	HP Symbol	Frame Size	Ratio	Hollow Shaft	Solid Shaft	
159	7293	1.00	I	20*	2B165	11	2070	1640	3.38–39
		1.47	II	20*	2C175	11	3480	2850	3.40–41
97.2	11931	1.00	I	20*	2B165	18	2070	1640	3.38–39
		1.47	II	20*	2C175	18	3480	2850	3.40–41
62.5	18555	1.00	I	20	2B165	28	2070	1640	3.38–39
44.9	25828	1.02	I	20	2C165	39	3480	2850	3.40–41
38.0	30517	1.24	I	20	2C175	46	3480	2850	3.40–41

25 HP

Output Speed RPM	Output Torque in•lb	Service Factor		SELECTION			Overhung Load (lbs)		Dimension Page LHYM
		SF	AGMA Class	HP Symbol	Frame Size	Ratio	Hollow Shaft	Solid Shaft	
159	9117	1.08	I	25*	2C170	11	3480	2850	3.40–41
97.2	14913	1.08	I	25*	2C170	18	3480	2850	3.40–41

* These Models are not available for Y4 Mounting Position

This page intentionally left blank.

Dimensions Gearmotors

Single Reduction LHYM-2A100~2B165

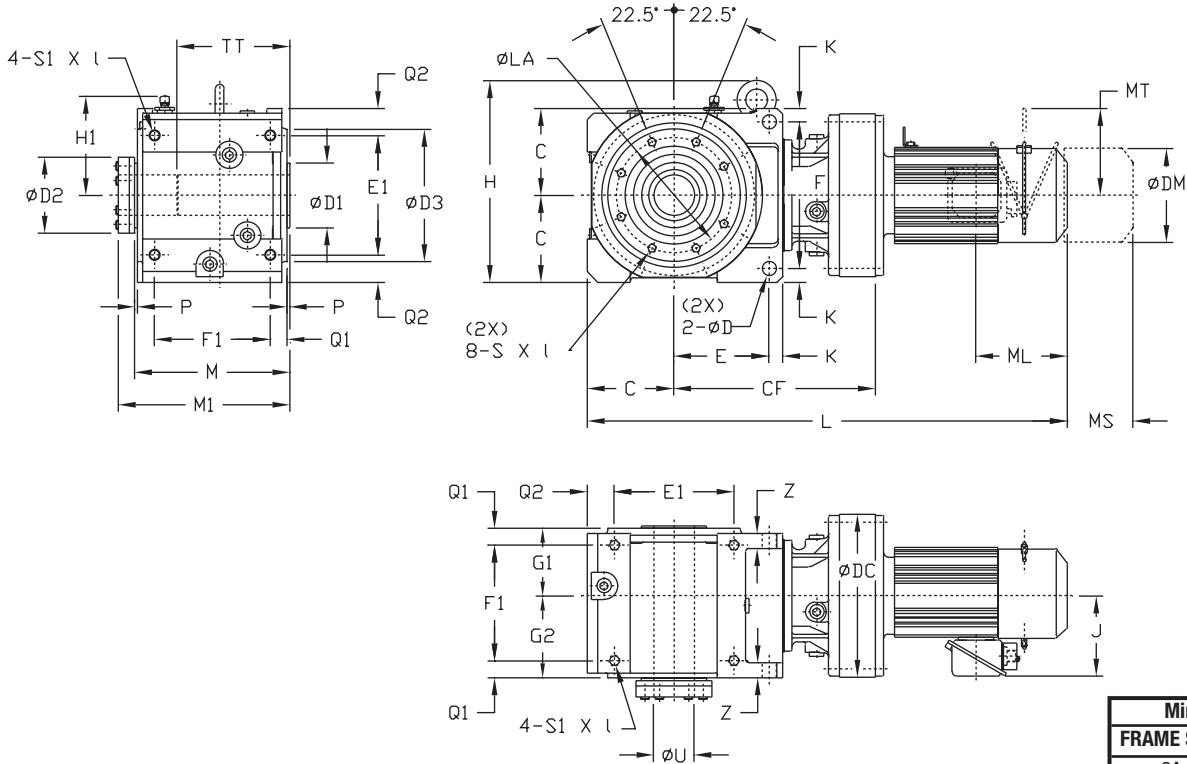

Gearmotors

Dimensions

Min. Engagement	
FRAME SIZE	TT
2A	7.79
2B	9.33
2C	10.16
2D	11.82
2E	13.94

All dimensions are in inches.

Model	CF	ϕDC	C	E	F	K	Z	ϕD	E1	F1	Q1	Q2	S1 x l
2A100, 2A105	9.33	5.91											
2A110, 2A115	9.76	6.38	4.33	4.61	7.48	0.59	0.87	0.71	5.91	6.30	0.91	1.38	M12 x 0.79
2A120, 2A125	9.57	8.03											
2A140, 2A145	10.43	9.06											
2B120, 2B125	11.02	8.03											
2B140, 2B145	11.69	9.06	5.12	5.71	8.66	0.79	1.02	0.87	7.48	7.68	1.06	1.38	M16 x 1.02
2B160, 2B165	12.83	11.81											

Model	M	P	G1	G2	H	H1	ϕLA	$\phi D3$	S x l	M1	$\phi D1$	$\phi D2$	ϕU	
													Std & Max	Min
2A100, 2A105														
2A110, 2A115	8.50	0.20	3.78	4.33	10.87	5.16	6.10	6.89	M10 x 0.67	9.84	3.35	4.09	2-3/16	1-11/16
2A120, 2A125														
2A140, 2A145														
2B120, 2B125														
2B140, 2B145	10.20	0.20	4.80	5.00	12.13	5.94	6.89	7.83	M12 x 0.79	11.54	3.94	4.49	2-7/16	1-15/16
2B160, 2B165														

Dimensions shown are for reference only and are subject to change without notice, unless certified. Certified prints are available after receipt of an order; consult factory.

Single Reduction LHYM-2A100~2B165 Dimensions

All dimensions are in inches.

Model	4 Pole Motor HP	Without Brake					With Brake						
		L	ØDM	J	ML	W (lb)	L	ØDM	J	ML	MS	MT	W (lb)
2A100, 2A105	1/4	20.61	4.88	5.04	2.32	115	21.85	4.88	5.04	3.58	2.40	-	117
	1/3	20.61	4.88	5.04	2.32	115	21.85	4.88	5.04	3.58	2.40	-	117
	1/2	21.39	4.88	5.04	2.32	117	22.64	4.88	5.04	3.58	2.40	-	121
	3/4	23.01	5.83	5.43	3.82	126	24.69	5.83	5.43	5.51	3.66	4.17	132
	1	23.01	5.83	5.43	3.82	126	24.69	5.83	5.43	5.51	3.66	4.17	132
	1.5	24.31	6.30	5.63	3.94	135	26.73	6.30	5.63	6.38	4.53	4.49	146
	2	24.31	6.30	5.63	3.94	135	26.73	6.30	5.63	6.38	4.53	4.49	146
	3	25.09	6.81	5.91	4.13	143	27.56	6.81	5.91	6.61	4.76	4.88	159
2A110, 2A115	1/2	21.70	4.88	5.04	2.32	126	22.91	4.88	5.04	3.58	2.40	-	130
	3/4	23.28	5.83	5.43	3.82	132	25.20	5.83	5.43	5.51	3.66	4.17	139
	1	23.28	5.83	5.43	3.82	132	25.20	5.83	5.43	5.51	3.66	4.17	139
	1.5	24.58	6.30	5.63	3.94	141	26.81	6.30	5.63	6.38	4.53	4.49	152
	2	24.58	6.30	5.63	3.94	141	26.81	6.30	5.63	6.38	4.53	4.49	152
	3	25.37	6.81	5.91	4.13	150	27.83	6.81	5.91	6.61	4.76	4.88	165
	5	26.74	8.35	6.54	5.00	170	29.57	8.35	6.54	7.83	5.20	6.18	192
2A120, 2A125	1.5	24.53	6.30	5.63	3.94	150	26.97	6.30	5.63	6.38	4.53	4.49	161
	2	24.53	6.30	5.63	3.94	150	26.97	6.30	5.63	6.38	4.53	4.49	161
	3	25.31	6.81	5.91	4.13	159	27.80	6.81	5.91	6.61	4.76	4.88	174
	5	26.22	8.35	6.54	5.00	181	29.06	8.35	6.54	7.83	5.20	6.18	203
	7.5	27.95	8.35	6.54	5.00	196	30.79	8.35	6.54	7.83	5.20	6.18	218
2A140, 2A145	7.5	28.81	8.35	6.54	5.00	212	31.65	8.35	6.54	7.83	5.20	6.18	234
	10	29.73	9.49	8.31	5.63	243	33.46	9.49	8.31	9.37	6.69	7.17	282
	15	32.09	9.88	8.31	5.63	273	35.83	9.88	8.31	9.37	6.69	7.17	313
	20	35.63	12.76	9.13	11.61	395	39.76	12.76	9.13	15.16	8.66	-	467
2B120, 2B125	3/4	25.49	5.83	5.43	3.82	203	27.17	5.83	5.43	5.51	3.66	4.17	209
	1	25.49	5.83	5.43	3.82	203	27.17	5.83	5.43	5.51	3.66	4.17	209
	1.5	26.79	6.30	5.63	3.94	212	29.21	6.30	5.63	6.38	4.53	4.49	223
	2	26.79	6.30	5.63	3.94	212	29.21	6.30	5.63	6.38	4.53	4.49	223
	3	27.57	6.81	5.91	4.13	221	30.04	6.81	5.91	6.61	4.76	4.88	236
	5	28.48	8.35	6.54	5.00	243	31.30	8.35	6.54	7.83	5.20	6.18	265
	7.5	30.21	8.35	6.54	5.00	258	33.03	8.35	6.54	7.83	5.20	6.18	280
2B140, 2B145	1	26.14	5.83	5.43	3.82	221	27.83	5.83	5.43	5.51	3.66	4.17	227
	1.5	27.44	6.30	5.63	3.94	229	29.88	6.30	5.63	6.38	4.53	4.49	240
	2	27.44	6.30	5.63	3.94	229	29.88	6.30	5.63	6.38	4.53	4.49	240
	3	28.23	6.81	5.91	4.13	236	30.71	6.81	5.91	6.61	4.76	4.88	251
	5	29.13	8.35	6.54	5.00	258	31.97	8.35	6.54	7.83	5.20	6.18	280
	7.5	30.87	8.35	6.54	5.00	273	33.70	8.35	6.54	7.83	5.20	6.18	295
	10	31.77	9.49	8.31	5.63	304	35.51	9.49	8.31	9.37	6.69	7.17	344
	15	34.13	9.88	8.31	5.63	335	37.87	9.88	8.31	9.37	6.69	7.17	375
	20	37.68	12.76	9.13	11.61	456	41.81	12.76	9.13	15.16	8.66	-	529
2B160, 2B165	5	30.29	8.35	6.54	5.00	304	33.11	8.35	6.54	7.83	5.20	6.18	326
	7.5	32.02	8.35	6.54	5.00	320	34.84	8.35	6.54	7.83	5.20	6.18	342
	10	33.12	9.49	8.31	5.63	353	36.85	9.49	8.31	9.37	6.69	7.17	392
	15	35.48	9.88	8.31	5.63	384	39.21	9.88	8.31	9.37	6.69	7.17	421
	20	38.83	12.76	9.13	11.61	503	42.95	12.76	9.13	15.16	8.66	-	576
	25	42.56	15.51	11.69	13.39	657	49.06	15.51	11.69	21.65	14.45	-	770
	30	42.56	15.51	11.69	13.39	657	49.06	15.51	11.69	21.65	14.45	-	770

Gearmotors

Dimensions

Dimensions shown are for reference only and are subject to change without notice, unless certified. Certified prints are available after receipt of an order; consult factory.

Dimensions

Single Reduction LHYM-2C140~2E175

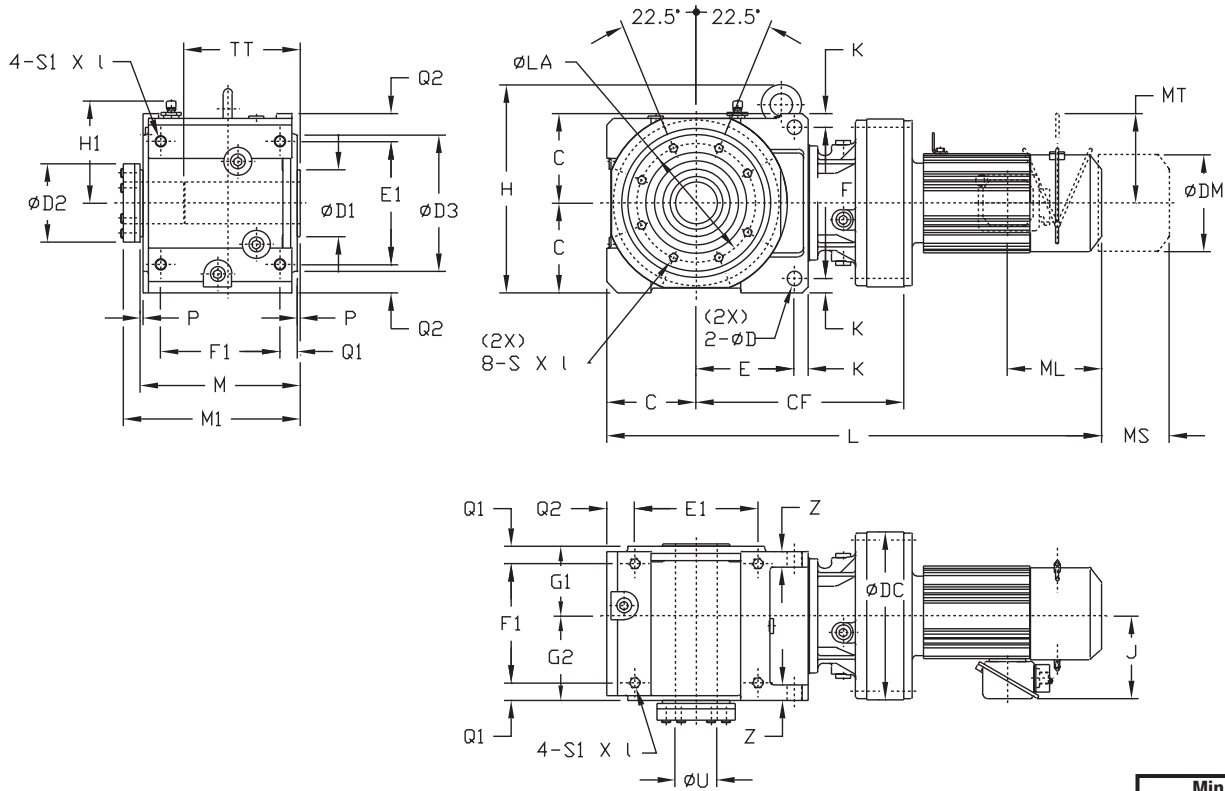

Gearmotors

Dimensions

Min. Engagement	
FRAME SIZE	TT
2A	7.79
2B	9.33
2C	10.16
2D	11.82
2E	13.94

All dimensions are in inches.

Model	CF	ϕDC	C	E	F	K	Z	ϕD	E1	F1	Q1	Q2	S1 x l
2C140, 2C145	14.02	9.06											
2C160, 2C165	14.84	11.81	6.30	6.89	10.63	0.98	1.18	1.02	8.66	8.39	1.22	1.97	M20 x 1.30
2C170, 2C175	15.47	13.39											
2D160, 2D165	17.68	11.81	7.48	7.87	12.76	1.10	1.57	1.30	9.84	10.00	1.42	2.56	M24 x 1.57
2D170, 2D175	17.44	13.39											
2E170, 2E175	18.43	13.39	8.46	9.06	14.17	1.38	1.57	1.30	11.81	11.14	1.50	2.56	M24 x 1.57

Model	M	P	G1	G2	H	H1	ϕLA	$\phi D3$	S x l	M1	$\phi D1$	$\phi D2$	ϕU	
													Std & Max	Min
2C140, 2C145														
2C160, 2C165	11.22	0.20	4.88	5.94	14.33	7.20	8.35	9.61	M16 x 1.02	12.83	4.72	5.43	2-15/16	2-3/16
2C170, 2C175														
2D160, 2D165	13.39	0.28	5.83	7.01	16.69	8.39	10.04	11.61	M20 x 1.30	15.00	5.51	5.98	3-7/16	2-7/16
2D170, 2D175														
2E170, 2E175	14.69	0.28	6.14	7.99	19.61	9.37	11.02	12.60	M20 x 1.38	16.30	6.30	6.69	3-15/16	2-15/16

Dimensions shown are for reference only and are subject to change without notice, unless certified. Certified prints are available after receipt of an order; consult factory.

Single Reduction LHYM-2C140~2E175 Dimensions

All dimensions are in inches.

Model	4 Pole Motor HP	Without Brake					With Brake						
		L	ØDM	J	ML	W (lb)	L	ØDM	J	ML	MS	MT	W (lb)
2C140, 2C145	1.5	30.94	6.30	5.63	3.94	333	33.39	6.30	5.63	6.38	4.53	4.49	344
	2	30.94	6.30	5.63	3.94	333	33.39	6.30	5.63	6.38	4.53	4.49	344
	3	31.73	6.81	5.91	4.13	340	34.21	6.81	5.91	6.61	4.76	4.88	355
	5	32.64	8.35	6.54	5.00	362	35.47	8.35	6.54	7.83	5.20	6.18	384
	7.5	34.37	8.35	6.54	5.00	377	37.20	8.35	6.54	7.83	5.20	6.18	399
	10	35.28	9.88	8.31	5.63	408	39.02	9.88	8.31	9.37	6.69	7.17	448
	15	37.64	9.88	8.31	5.63	439	41.38	9.88	8.31	9.37	6.69	7.17	478
	20	41.18	12.76	9.13	11.61	560	45.31	12.76	9.13	15.16	8.66	-	635
2C160, 2C165	2	31.97	6.30	5.63	3.94	379	34.41	6.30	5.63	6.38	4.53	4.49	390
	3	32.56	6.81	5.91	4.13	386	35.04	6.81	5.91	6.61	4.76	4.88	401
	5	33.46	8.35	6.54	5.00	406	36.30	8.35	6.54	7.83	5.20	6.18	428
	7.5	35.20	8.35	6.54	5.00	421	38.03	8.35	6.54	7.83	5.20	6.18	443
	10	36.30	9.88	8.31	5.63	454	40.04	9.88	8.31	9.37	6.69	7.17	494
	15	38.66	9.88	8.31	5.63	485	42.40	9.88	8.31	9.37	6.69	7.17	523
	20	42.01	12.76	9.13	11.61	604	46.14	12.76	9.13	15.16	8.66	-	679
	25	45.75	15.51	11.69	13.39	759	52.24	15.51	11.69	21.65	14.45	-	871
2C170, 2C175	5	34.69	8.35	6.54	5.00	456	37.52	8.35	6.54	7.83	5.20	6.18	478
	7.5	36.42	8.35	6.54	5.00	472	39.25	8.35	6.54	7.83	5.20	6.18	494
	10	37.13	9.88	8.31	5.63	505	40.87	9.88	8.31	9.37	6.69	7.17	545
	15	39.49	9.88	8.31	5.63	536	43.23	9.88	8.31	9.37	6.69	7.17	576
	20	42.64	12.76	9.13	11.61	655	46.77	12.76	9.13	15.16	8.66	-	730
	25	46.38	15.51	11.69	13.39	584	52.87	15.51	11.69	21.65	14.45	-	917
	30	46.38	15.51	11.69	13.39	584	52.87	15.51	11.69	21.65	14.45	-	917
	40	46.38	15.51	11.69	13.39	856	52.87	15.51	11.69	21.65	14.57	-	950
2D160, 2D165	3	36.57	6.81	5.91	4.13	534	39.06	6.81	5.91	6.61	4.76	4.88	549
	5	37.48	8.35	6.54	5.00	553	40.31	8.35	6.54	7.83	5.20	6.18	576
	7.5	39.21	8.35	6.54	5.00	569	42.05	8.35	6.54	7.83	5.20	6.18	591
	10	40.31	9.88	8.31	5.63	602	44.06	9.88	8.31	9.37	6.69	7.17	642
	15	42.68	9.88	8.31	5.63	633	46.42	9.88	8.31	9.37	6.69	7.17	670
	20	46.02	12.76	9.13	11.61	752	50.16	12.76	9.13	15.16	8.66	-	827
	25	49.76	15.51	11.69	13.39	906	56.26	15.51	11.69	21.65	14.45	-	1019
	30	49.76	15.51	11.69	13.39	906	56.26	15.51	11.69	21.65	14.45	-	1019
2D170, 2D175	5	37.83	8.35	6.54	5.00	595	40.67	8.35	6.54	7.83	5.20	6.18	617
	7.5	39.57	8.35	6.54	5.00	611	42.40	8.35	6.54	7.83	5.20	6.18	633
	10	40.28	9.88	8.31	5.63	644	44.02	9.88	8.31	9.37	6.69	7.17	684
	15	42.64	9.88	8.31	5.63	675	46.38	9.88	8.31	9.37	6.69	7.17	714
	20	45.79	12.76	9.13	11.61	794	49.92	12.76	9.13	15.16	8.66	-	869
	25	49.53	15.51	11.69	13.39	944	56.02	15.51	11.69	21.65	14.45	-	1056
	30	49.53	15.51	11.69	13.39	944	56.02	15.51	11.69	21.65	14.45	-	1056
	40	49.53	15.51	11.69	13.39	994	56.02	15.51	11.69	21.65	14.57	-	1089
2E170, 2E175	5	39.80	8.35	6.54	5.00	759	42.64	8.35	6.54	7.83	5.20	6.18	781
	7.5	41.54	8.35	6.54	5.00	774	44.37	8.35	6.54	7.83	5.20	6.18	796
	10	42.24	9.88	8.31	5.63	807	45.98	9.88	8.31	9.37	6.69	7.17	847
	15	44.61	9.88	8.31	5.63	838	48.35	9.88	8.31	9.37	6.69	7.17	878
	20	47.76	12.76	9.13	11.61	957	51.89	12.76	9.13	15.16	8.66	-	1032
	25	51.50	15.51	11.69	13.39	1107	57.99	15.51	11.69	21.65	14.45	-	1219
	30	51.50	15.51	11.69	13.39	1107	57.99	15.51	11.69	21.65	14.45	-	1219
	40	51.50	15.51	11.69	13.39	1158	57.99	15.51	11.69	21.65	14.57	-	1252

Dimensions shown are for reference only and are subject to change without notice, unless certified.
Certified prints are available after receipt of an order; consult factory.

Dimensions

Double Reduction LHYM-2A10DA~2C16DB

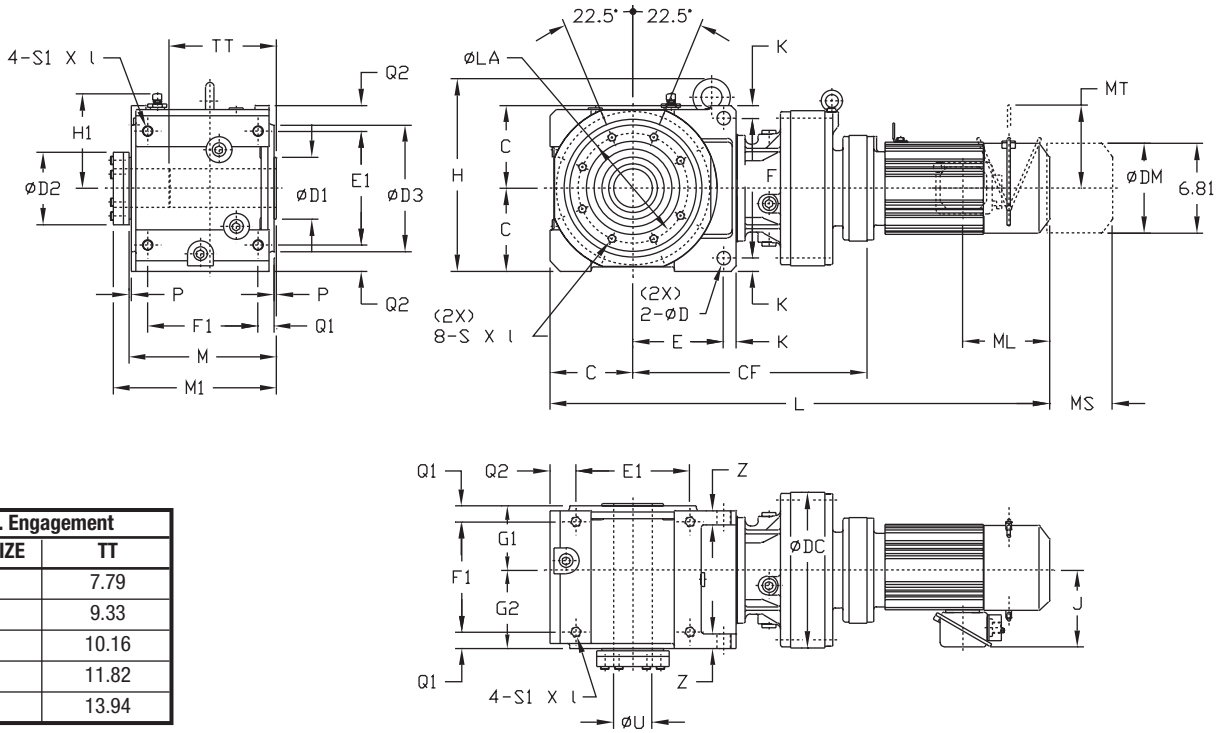

Min. Engagement	
FRAME SIZE	TT
2A	7.79
2B	9.33
2C	10.16
2D	11.82
2E	13.94

All dimensions are in inches.

Model	CF	ϕDC	C	E	F	K	Z	ϕD	E1	F1	Q1	Q2	S1 x l	M
2A10DA	11.22	5.91												
2A12DA	11.69	8.03	4.33	4.61	7.48	0.59	0.87	0.71	5.91	6.30	0.91	1.38	M12x0.79	8.50
2A12DB	12.17	8.03												
2B12DA	13.15	8.03												
2B12DB	13.62	8.03	5.12	5.71	8.66	0.79	1.02	0.87	7.48	7.68	1.06	1.38	M16x1.02	10.20
2B14DA	13.82	9.06												
2B14DB	14.17	9.06												
2C14DA	16.14	9.06												
2C14DB	16.50	9.06	6.30	6.89	10.63	0.98	1.18	1.02	8.66	8.39	1.22	1.97	M20x1.30	11.22
2C14DC	17.05	9.06												
2C16DA	17.40	11.81												
2C16DB	17.95	11.81												

Model	P	G1	G2	H	H1	ϕLA	$\phi D3$	S1 x l	M1	$\phi D1$	$\phi D2$	ϕU	
												Std & Max	Min
2A10DA													
2A12DA	0.20	3.78	4.33	10.87	5.16	6.10	6.89	M10 x 0.67	9.84	3.35	4.09	2-3/16	1-11/16
2A12DB													
2B12DA													
2B12DB	0.20	4.80	5.00	12.13	5.94	6.89	7.83	M12 x 0.79	11.54	3.94	4.49	2-7/16	1-15/16
2B14DA													
2B14DB													
2C14DA													
2C14DB	0.20	4.88	5.94	14.33	7.20	8.35	9.61	M16 x 1.02	12.83	4.72	5.43	2-15/16	2-3/16
2C14DC													
2C16DA													
2C16DB													

Dimensions shown are for reference only and are subject to change without notice, unless certified. Certified prints are available after receipt of an order; consult factory.

Double Reduction LHYM-2A10DA~2C16DB Dimensions

All dimensions are in inches.

Model	4 Pole Motor HP	Without Brake					With Brake						
		L	ØDM	J	ML	W (lb)	L	ØDM	J	ML	MS	MT	W (lb)
2A10DA	1/8	20.83	4.88	5.04	1.38	117	22.20	4.88	5.04	2.76	2.40	-	119
	1/4	22.48	4.88	5.04	2.32	119	23.74	4.88	5.04	3.58	2.40	-	121
	1/3	22.48	4.88	5.04	2.32	119	23.74	4.88	5.04	3.58	2.40	-	121
	1/2	23.27	4.88	5.04	2.32	121	24.53	4.88	5.04	3.58	2.40	-	123
2A12DA	1/8	21.30	4.88	5.04	1.38	135	22.68	4.88	5.04	2.76	2.40	-	137
	1/4	22.95	4.88	5.04	2.32	137	24.21	4.88	5.04	3.58	2.40	-	139
	1/3	22.95	4.88	5.04	2.32	137	24.21	4.88	5.04	3.58	2.40	-	139
	1/2	23.74	4.88	5.04	2.32	139	25.00	4.88	5.04	3.58	2.40	-	141
2A12DB	1/3	23.43	4.88	5.04	2.32	143	24.69	4.88	5.04	3.58	2.40	-	148
	1/2	24.21	4.88	5.04	2.32	146	25.47	4.88	5.04	3.58	2.40	-	150
	3/4	25.83	5.83	5.43	3.82	154	27.52	5.83	5.43	5.51	3.66	4.17	161
	1	25.83	5.83	5.43	3.82	154	27.52	5.83	5.43	5.51	3.66	4.17	161
2B12DA	1/8	23.54	4.88	5.04	1.38	198	24.92	4.88	5.04	2.76	2.40	-	201
	1/4	25.20	4.88	5.04	2.32	201	26.46	4.88	5.04	3.58	2.40	-	203
	1/3	25.20	4.88	5.04	2.32	201	26.46	4.88	5.04	3.58	2.40	-	203
	1/2	25.98	4.88	5.04	2.32	203	27.24	4.88	5.04	3.58	2.40	-	205
2B12DB	1/3	25.67	4.88	5.04	2.32	207	26.93	4.88	5.04	3.58	2.40	-	212
	1/2	26.46	4.88	5.04	2.32	209	27.72	4.88	5.04	3.58	2.40	-	214
	3/4	28.07	5.83	5.43	3.82	218	29.76	5.83	5.43	5.51	3.66	4.17	225
	1	28.07	5.83	5.43	3.82	218	29.76	5.83	5.43	5.51	3.66	4.17	225
	1.5	29.37	6.30	5.63	3.94	225	31.81	6.30	5.63	6.38	4.53	4.49	236
2B14DA	1/4	25.87	4.88	5.04	2.32	209	27.13	4.88	5.04	3.58	2.40	-	212
	1/3	25.87	4.88	5.04	2.32	209	27.13	4.88	5.04	3.58	2.40	-	212
	1/2	26.65	4.88	5.04	2.32	212	27.91	4.88	5.04	3.58	2.40	-	214
2B14DB	1/4	26.22	4.88	5.04	2.32	214	27.48	4.88	5.04	3.58	2.40	-	218
	1/2	27.01	4.88	5.04	2.32	216	28.27	4.88	5.04	3.58	2.40	-	221
	3/4	28.62	5.83	5.43	3.82	225	30.31	5.83	5.43	5.51	3.66	4.17	232
	1	28.62	5.83	5.43	3.82	225	30.31	5.83	5.43	5.51	3.66	4.17	232
	1.5	29.92	6.30	5.63	3.94	232	32.36	6.30	5.63	6.38	4.53	4.49	243
	2	29.92	6.30	5.63	3.94	232	32.36	6.30	5.63	6.38	4.53	4.49	243
2C14DA	1/4	29.37	4.88	5.04	2.32	313	30.63	4.88	5.04	3.58	2.40	-	315
	1/3	29.37	4.88	5.04	2.32	313	30.63	4.88	5.04	3.58	2.40	-	315
	1/2	30.16	4.88	5.04	2.32	315	31.42	4.88	5.04	3.58	2.40	-	318
2C14DB	1/4	29.72	4.88	5.04	2.32	318	30.98	4.88	5.04	3.58	2.40	-	322
	1/3	29.72	4.88	5.04	2.32	318	30.98	4.88	5.04	3.58	2.40	-	322
	1/2	30.51	4.88	5.04	2.32	320	31.77	4.88	5.04	3.58	2.40	-	324
	3/4	32.13	5.83	5.43	3.82	329	33.82	5.83	5.43	5.51	3.66	4.17	335
	1	32.13	5.83	5.43	3.82	329	33.82	5.83	5.43	5.51	3.66	4.17	335
	1.5	33.43	6.30	5.63	3.94	335	35.87	6.30	5.63	6.38	4.53	4.49	346
	2	33.43	6.30	5.63	3.94	335	35.87	6.30	5.63	6.38	4.53	4.49	346
2C14DC	1.5	33.98	6.30	5.63	3.94	342	36.42	6.30	5.63	6.38	4.53	4.49	353
	2	33.98	6.30	5.63	3.94	342	36.42	6.30	5.63	6.38	4.53	4.49	353
	3	34.76	6.81	5.91	4.13	351	37.24	6.81	5.91	6.61	4.76	4.88	364
2C16DA	1/2	31.42	4.88	5.04	2.32	373	32.68	4.88	5.04	3.58	2.40	-	377
	3/4	33.03	5.83	5.43	3.82	381	34.72	5.83	5.43	5.51	3.66	4.17	388
	1	33.03	5.83	5.43	3.82	381	34.72	5.83	5.43	5.51	3.66	4.17	388
	1.5	34.33	6.30	5.63	3.94	390	32.83	6.30	5.63	6.38	4.53	4.49	401
	2	34.33	6.30	5.63	3.94	390	32.83	6.30	5.63	6.38	4.53	4.49	401
2C16DB	1.5	34.88	6.30	5.63	3.94	395	37.32	6.30	5.63	6.38	4.53	4.49	406
	2	34.88	6.30	5.63	3.94	395	37.32	6.30	5.63	6.38	4.53	4.49	406
	3	35.67	6.81	5.91	4.13	481	38.15	6.81	5.91	6.61	4.76	4.88	494

Gearmotors

Dimensions

Dimensions shown are for reference only and are subject to change without notice, unless certified.
 Certified prints are available after receipt of an order; consult factory.

Dimensions

Double Reduction LHYM-2D16DA~2E17DC

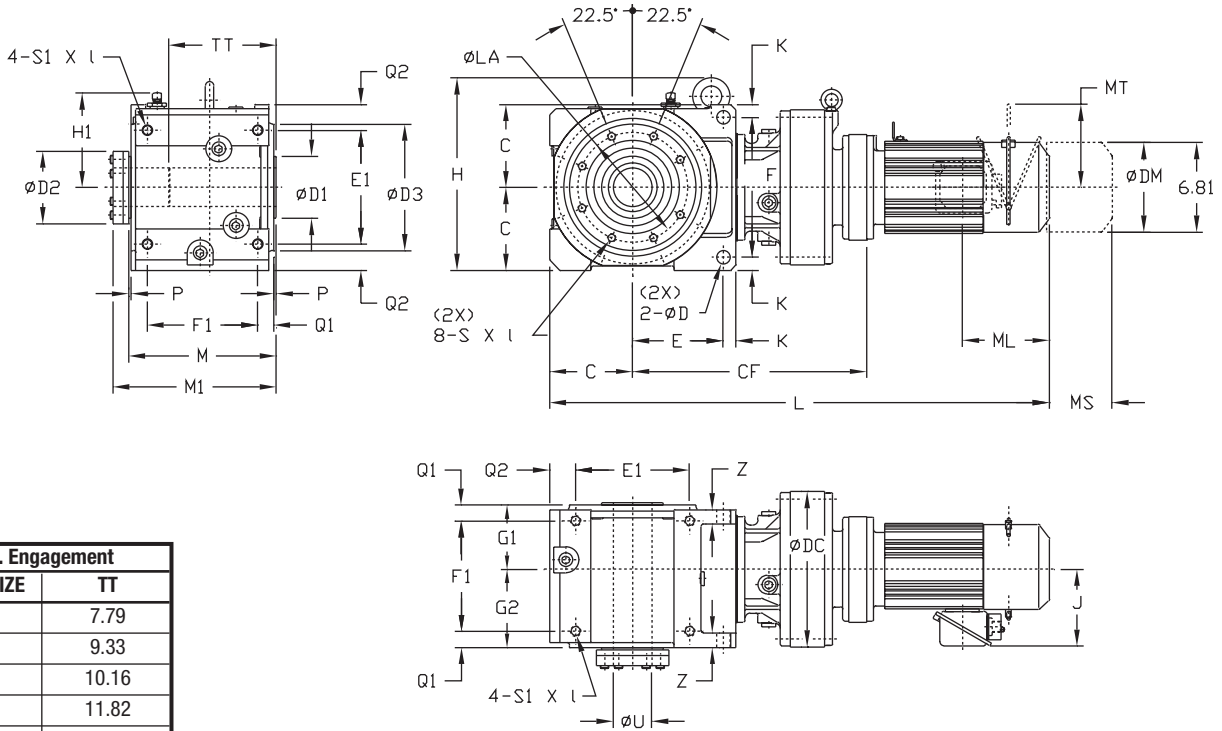

Min. Engagement	
FRAME SIZE	TT
2A	7.79
2B	9.33
2C	10.16
2D	11.82
2E	13.94

Dimensions

All dimensions are in inches.

Model	CF	ØDC	C	E	F	K	Z	ØD	E1	F1	Q1	Q2	S1 x l	M
2D16DA	20.24	11.81												
2D16DB	20.79	11.81												
2D16DC	20.87	11.81	7.48	7.87	12.76	1.10	1.57	1.30	9.84	10.00	1.42	2.56	M24x1.57	13.39
2D17DA	20.04	13.39												
2D17DB	20.59	13.39												
2D17DC	20.75	13.39												
2E17DA	21.02	13.39												
2E17DB	21.57	13.39	8.46	9.06	14.17	1.38	1.57	1.30	11.81	11.14	1.50	2.56	M24x1.57	14.69
2E17DC	21.73	13.39												

Model	P	G1	G2	H	H1	ØLA	ØD3	S1 x l	M1	ØD1	ØD2	ØU	
												Std & Max	Min
2D16DA													
2D16DB													
2D16DC	0.28	5.83	7.01	16.69	8.39	10.04	11.61	M20x1.30	15.00	5.51	5.98	3-7/16	2-7/16
2D17DA													
2D17DB													
2D17DC													
2E17DA													
2E17DB	0.28	6.14	7.99	19.61	9.37	11.02	12.60	M20x1.38	16.30	6.30	6.69	3-15/16	2-15/16
2E17DC													

Dimensions shown are for reference only and are subject to change without notice, unless certified. Certified prints are available after receipt of an order; consult factory.

Double Reduction LHYM-2D16DA~2E17DC Dimensions

All dimensions are in inches.

Model	4 Pole Motor HP	Without Brake					With Brake						
		L	ØDM	J	ML	W (lb)	L	ØDM	J	ML	MS	MT	W (lb)
2D16DA	1/4	33.46	4.88	5.04	2.32	518	34.72	4.88	5.04	3.58	2.40	-	523
	1/3	33.46	4.88	5.04	2.32	518	34.72	4.88	5.04	3.58	2.40	-	523
	1/2	34.25	4.88	5.04	2.32	520	35.51	4.88	5.04	3.58	2.40	-	525
	3/4	35.87	5.83	5.43	3.82	529	37.56	5.83	5.43	5.51	3.66	4.17	536
	1	35.87	5.83	5.43	3.82	529	37.56	5.83	5.43	5.51	3.66	4.17	536
	1.5	37.17	6.30	5.63	3.94	538	39.61	6.30	5.63	6.38	4.53	4.49	549
	2	37.17	6.30	5.63	3.94	538	39.61	6.30	5.63	6.38	4.53	4.49	549
2D16DB	1.5	37.72	6.30	5.63	3.94	542	40.16	6.30	5.63	6.38	4.53	4.49	553
	2	37.72	6.30	5.63	3.94	542	40.98	6.30	5.63	6.38	4.53	4.49	553
	3	38.50	6.81	5.91	4.13	551	40.98	6.81	5.91	6.61	4.76	4.88	564
2D16DC	5	40.67	8.35	6.54	5.00	587	43.50	8.35	6.54	7.83	5.20	6.18	609
2D17DA	1/2	34.06	4.88	5.04	2.32	549	35.31	4.88	5.04	3.58	2.40	-	553
	3/4	35.67	5.83	5.43	3.82	558	37.36	5.83	5.43	5.51	3.66	4.17	564
	1	35.67	5.83	5.43	3.82	558	37.36	5.83	5.43	5.51	3.66	4.17	564
	1.5	36.97	6.30	5.63	3.94	564	39.41	6.30	5.63	6.38	4.53	4.49	576
	2	36.97	6.30	5.63	3.94	564	39.41	6.30	5.63	6.38	4.53	4.49	576
2D17DB	2	37.52	6.30	5.63	3.94	571	38.31	6.30	5.63	6.38	4.53	4.49	582
	3	39.96	6.81	5.91	4.13	580	40.79	6.81	5.91	6.61	4.76	4.88	593
2D17DC	3	38.46	6.81	5.91	4.13	591	40.94	6.81	5.91	6.61	4.76	4.88	606
	4	39.37	8.35	6.54	5.00	613	42.20	8.35	6.54	7.83	5.20	6.18	635
	5	39.37	8.35	6.54	5.00	613	42.20	8.35	6.54	7.83	5.20	6.18	635
2E17DA	1/4	36.42	4.88	5.04	2.32	710	37.68	4.88	5.04	3.58	2.40	-	714
	1/3	36.42	4.88	5.04	2.32	710	37.68	4.88	5.04	3.58	2.40	-	714
	1/2	37.20	4.88	5.04	2.32	712	38.46	4.88	5.04	3.58	2.40	-	717
	3/4	38.82	5.83	5.43	3.82	721	40.51	5.83	5.43	5.51	3.66	4.17	728
	1	38.82	5.83	5.43	3.82	721	40.51	5.83	5.43	5.51	3.66	4.17	728
	1.5	40.12	6.30	5.63	3.94	728	42.56	6.30	5.63	6.38	4.53	4.49	739
	2	40.12	6.30	5.63	3.94	728	42.56	6.30	5.63	6.38	4.53	4.49	739
2E17DB	1.5	40.67	6.30	5.63	3.94	734	43.11	6.30	5.63	6.38	4.53	4.49	745
	2	40.67	6.30	5.63	3.94	734	43.11	6.30	5.63	6.38	4.53	4.49	745
	3	43.11	6.81	5.91	4.13	743	43.94	6.81	5.91	6.61	4.76	4.88	756
2E17DC	3	41.61	6.81	5.91	4.13	754	44.09	6.81	5.91	6.61	4.76	4.88	770
	4	42.52	8.35	6.54	5.00	776	45.35	8.35	6.54	7.83	5.20	6.18	798
	5	42.52	8.35	6.54	5.00	776	45.35	8.35	6.54	7.83	5.20	6.18	798
	7.5	44.25	8.35	6.54	5.00	792	47.09	8.35	6.54	7.83	5.20	6.18	814

Gearmotors

Dimensions

Dimensions shown are for reference only and are subject to change without notice, unless certified. Certified prints are available after receipt of an order; consult factory.

This page intentionally left blank.

Gearmotors



4

Options

Options

All dimensions are in inches. Dimensions shown are for reference only and are subject to change without notice, unless certified. Certified prints are available after receipt of an order; consult factory.

Keyed Hollow Shaft

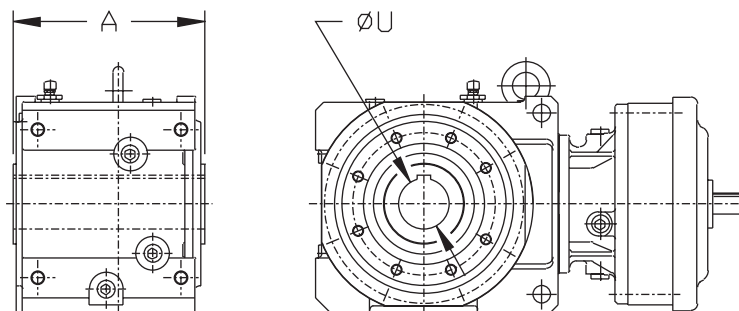

Frame Size	ØU	A	Keyway	TK*
2A	2.000	8.50	1/2 x 1/4	6.50
2B	2.375	10.20	5/8 x 5/16	7.87
2C	2.750	11.22	5/8 x 5/16	9.76
2D	3.250	13.39	3/4 X 3/8	11.93
2E	4.000	14.69	1 X 1/2	10.24

*Recommended minimum shaft engagement

Cyclo BBB

Options

Solid Output Shaft

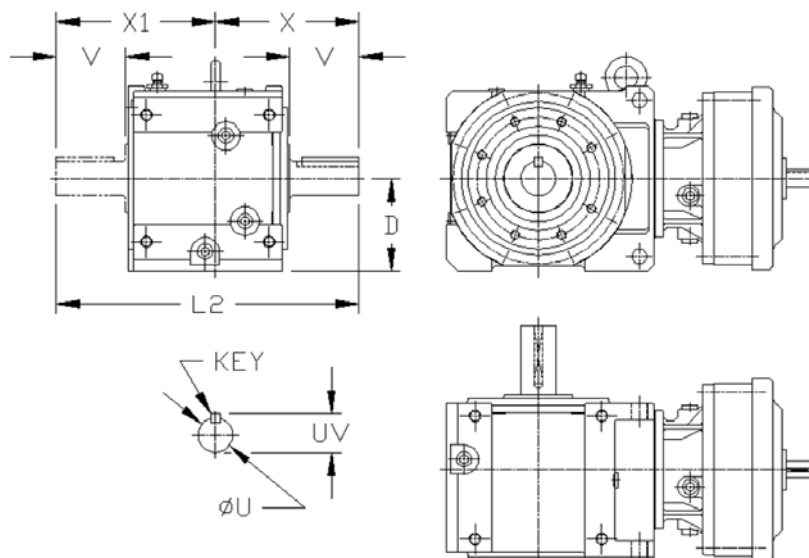

Frame Size	ØU	UV	D	V	X	Key	X1	L2
2A	2.000	2.22	4.33	3.54	7.48	1/2 x 1/2 x 2.76	8.11	15.59
2B	2.875	3.20	5.12	4.53	9.33	3/4 x 3/4 x 3.15	9.72	19.25
2C	3.125	3.45	6.30	5.71	10.79	3/4 x 3/4 x 4.72	11.85	22.64
2D	3.625	4.01	7.48	6.69	12.80	7/8 x 7/8 x 5.51	13.98	26.77
2E	4.375	4.82	8.46	7.87	14.29	1 x 1 x 6.30	16.14	30.43

All dimensions are in inches. Dimensions shown are for reference only and are subject to change without notice, unless certified. Certified prints are available after receipt of an order; consult factory.

Output Flange

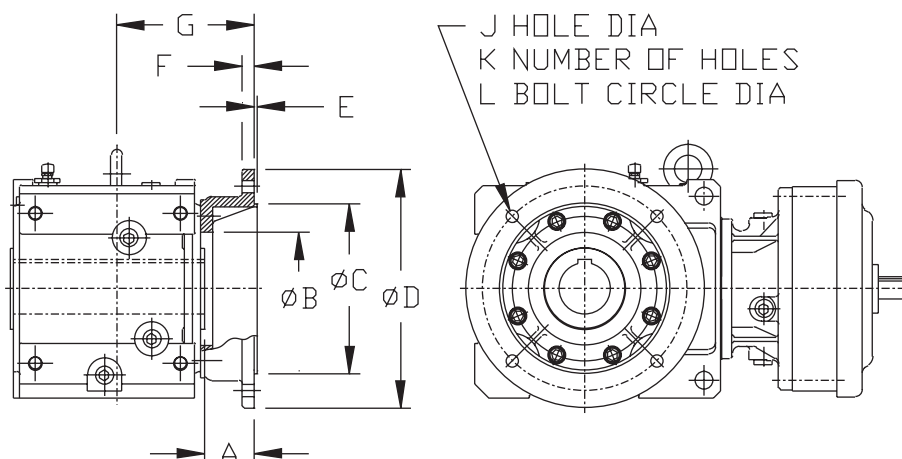

Frame Size	A	B	C	D	E	F	G	J	K	L
2A	2.36	4.72	7.09	9.84	0.16	0.59	6.30	0.55	4	8.46
2B	2.40	5.51	9.06	11.81	0.16	0.63	7.40	0.55	4	10.43
2C	2.87	6.50	9.84	13.78	0.20	0.71	7.95	0.71	4	11.81
2D	3.15	7.68	13.78	17.72	0.20	0.87	9.25	0.71	8	15.75
2E	3.15	8.66	13.78	17.72	0.20	0.87	9.57	0.71	8	15.75

Foot Mounted

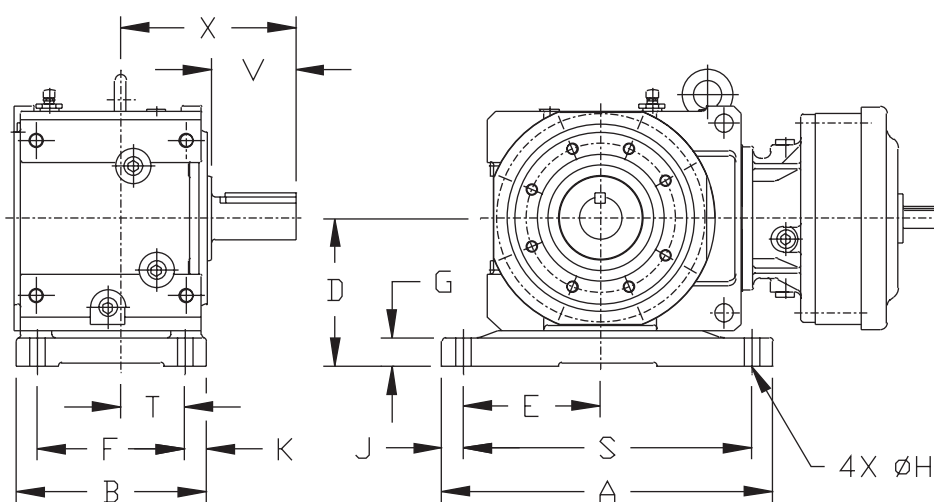

Frame Size	E	J	S	A	G	D	T	K	F	B	H	V	X
2A	5.31	0.79	11.02	12.60	0.98	5.51	2.83	0.83	6.30	7.95	0.55	3.54	7.48
2B	6.30	0.79	13.58	15.16	1.38	6.69	3.74	0.98	7.68	9.65	0.71	4.53	9.53
2C	7.68	1.18	17.52	19.88	1.57	8.27	3.58	1.18	8.27	10.63	0.87	5.71	10.79
2D	9.25	1.18	19.69	22.05	1.77	9.65	4.53	1.18	10.24	12.60	1.02	6.69	12.80
2E	10.63	1.38	22.83	25.59	1.77	10.83	4.57	1.50	11.02	13.98	1.30	7.87	14.29

Options

All dimensions are in inches. Dimensions shown are for reference only and are subject to change without notice, unless certified. Certified prints are available after receipt of an order; consult factory.

Torque Arm TURNBUCKLE TYPE

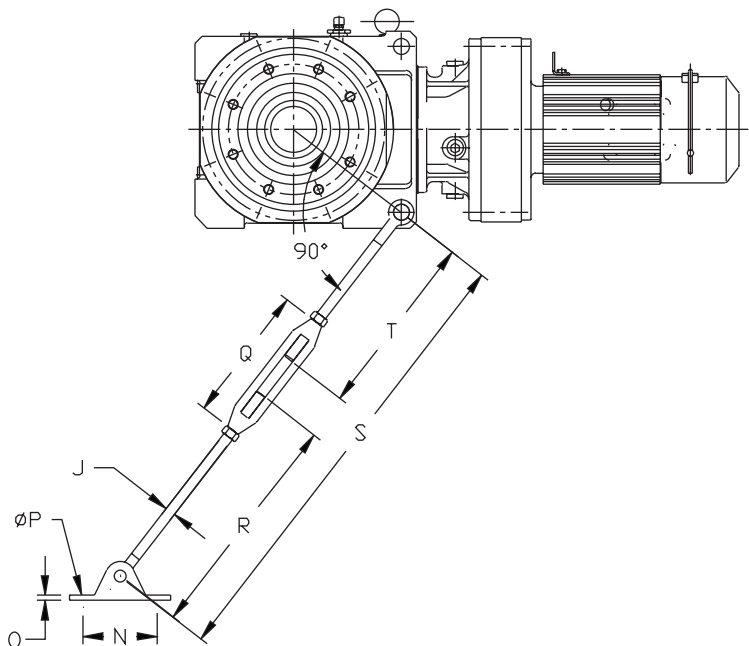

Turnbuckle Type										Bracket Type (optional)									
Frame Size	J	M	N	O	P	Q	R	S		T	Frame Size	L1	L2	W1	W2	T	ØD1	ØD2	Bolt Size
								Min	Max										
A	M20	0.71	3.94	0.47	0.63	8.50	14.76	25.20	31.10	10.43	A	6.34	7.52	1.42	2.60	0.79	0.71	2.09	M16
B	M20	0.87	3.94	0.47	0.63	8.50	14.76	25.79	31.69	11.02	B	7.68	9.09	1.89	3.31	1.02	0.87	2.60	M20
C	M24	1.02	4.72	0.71	0.63	8.74	14.76	26.57	32.48	11.81	C	9.13	10.91	2.40	4.17	1.18	1.02	3.27	M24
D	M24	1.30	4.72	0.71	0.63	8.74	14.76	27.95	33.86	13.19	D	10.98	13.15	2.91	5.08	1.42	1.30	4.06	M30
E	M24	1.30	4.72	0.71	0.63	8.74	14.76	27.95	33.86	13.19	E	12.05	14.21	2.91	5.08	1.42	1.30	4.06	M30

Torque Arm BRACKET TYPE (Optional)

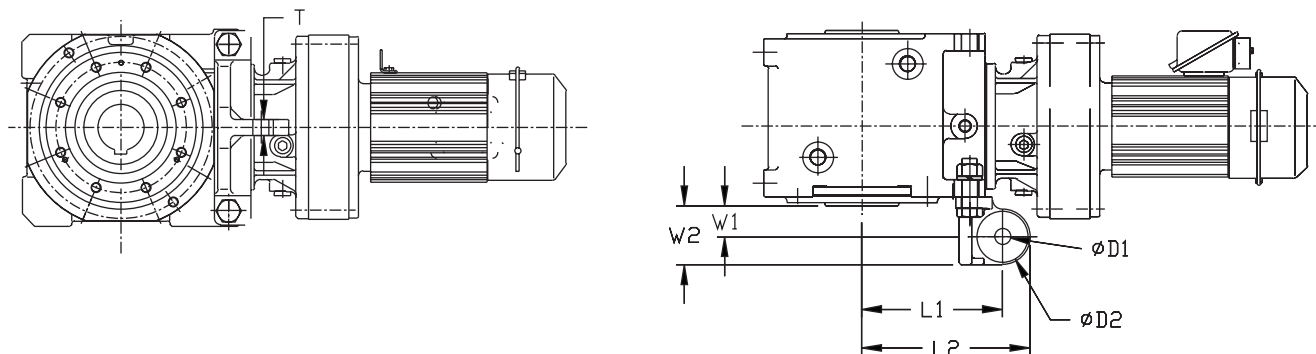

5

Appendix

Special Load Guidelines Overhung Load

Reducer/Gearmotor Allowable Overhung Load

When a sprocket, sheave, or gear is mounted on the slow speed shaft of a reducer, an overhung load is applied on that shaft. It is necessary to check if the shaft of the Cyclo BBB Speed Reducer will allow the overhung load. Calculate the overhung load using this formula:

$$\text{Overhung Load} = \frac{126,000 \times \text{HP} \times \text{Cf} \times \text{Lf} \times \text{Sf}}{\text{D} \times \text{N}}$$

LEGEND

- HP:** Horsepower transmitted by shaft
- Cf:** Load connection factor (Fig. 5.1)
- Lf:** Load location factor (Fig. 5.3 Output Shaft; Fig. 5.7 Input Shaft)
- Sf:** Service factor (Determine from Fig. 5.2 and "How to Select," pages 2.4 and 3.4)
- D:** Pitch diameter of sprocket, etc.
- N:** Shaft speed (rpm)

Figure 5.1 Load Connection Factor

Type of Connection	Cf
General Purpose Chain	1.0
Machined Gear, Pinion or Synchronous Belt	1.25
V-Belt	1.5
Flat Belt	2.5

Figure 5.2 Service Factor

Shock Factor	Sf
No Shock	1.0
Moderate Shock	1.5
Heavy Shock	2.0

Centerline of Load, Output

"L" indicates the distance from the hollow shaft end to the mid-point of the radial load.

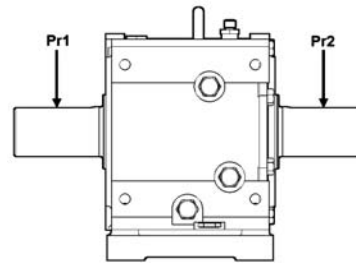
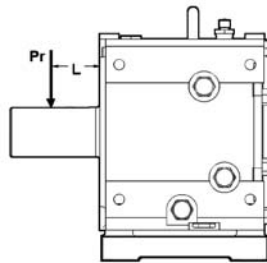

For double extended output shafts, Pr1 + Pr2 must be less than the Allowable Overhung Load.

Figure 5.3 Overhung Load Location Factor of Output Shaft, Lf (Keyed Hollow Bore, Tapered Grip Bushing)

Frame Size	L (inches)											
	1	1 1/4	1 1/2	1 3/4	2	2 1/2	3	3 1/2	4	4 1/2	5	6
2A100, 2A105, 2A110, 2A115, 2A120, 2A125, 2A140, 2A145,	1.04	1.08	1.12	1.16	1.19	1.27	1.35	1.42	-	-	-	-
2B120, 2B125, 2B140, 2B145, 2B160, 2B165	1.03	1.06	1.09	1.13	1.15	1.22	1.28	1.34	1.40	1.46	-	-
2C140, 2C145, 2C160, 2C165, 2C170, 2C175	1.02	1.06	1.08	1.11	1.14	1.20	1.25	1.31	1.37	1.42	1.48	-
2D160, 2D165, 2D170, 2D175,	1.02	1.05	1.07	1.09	1.11	1.16	1.21	1.26	1.31	1.35	1.39	1.49
2E170, 2E175	1.02	1.04	1.06	1.09	1.10	1.15	1.19	1.24	1.27	1.31	1.35	1.44

Figure 5.4 Allowable Overhung Load for Output Shaft (Keyed Hollow Bore, Tapered Grip Bushing) (Lf, Cf, Sf = 1) Unit: lbs.

Frame Size	Output Shaft Speed (RPM)									
	5	10	20	30	35	45	50	60	75	90
2A100, 2A105, 2A110, 2A115, 2A120, 2A125, 2A140, 2A145,	1124	1124	1124	1124	1124	1124	1124	1124	1124	1124
2B120, 2B125, 2B140, 2B145, 2B160, 2B165	2068	2068	2068	2068	2068	2068	2068	2068	2068	2068
2C140, 2C145, 2C160, 2C165, 2C170, 2C175	3484	3484	3484	3484	3484	3484	3484	3484	3484	3215
2D160, 2D165, 2D170, 2D175,	4811	4811	4811	4811	4811	4811	4811	4811	4811	3799
2E170, 2E175	5170	5170	5170	5170	5170	5170	5170	5170	5170	5170

Special Load Guidelines Overhung Load continued

Figure 5.5 Overhung Load Location Factor, Lf (Solid Output Shaft)

Frame Size	L (inches)											
	1	1 1/4	1 1/2	1 3/4	2	2 1/2	3	3 1/2	4	4 1/2	5	6
2A100, 2A105, 2A110, 2A115, 2A120, 2A125, 2A140, 2A145,	0.87	0.91	0.90	1.00	1.14	1.42	1.70	1.98	–	–	–	–
2B120, 2B125, 2B140, 2B145, 2B160, 2B165	0.83	0.87	0.90	0.94	0.97	1.11	1.33	1.55	1.77	1.99	–	–
2C140, 2C145, 2C160, 2C165, 2C170, 2C175	0.81	0.84	0.86	0.89	0.91	0.97	1.09	1.27	1.45	1.64	1.82	–
2D160, 2D165, 2D170, 2D175,	0.79	0.82	0.84	0.87	0.89	0.94	0.98	1.12	1.27	1.43	1.59	1.91
2E170, 2E175	0.78	0.81	0.83	0.85	0.87	0.91	0.95	1.00	1.14	1.28	1.42	1.70

Figure 5.6 Allowable Overhung Load for Output Shaft: (Solid Output Shaft) (Lf, Cf, Fs =1)

Unit: lbs.

Frame Size	Output Shaft Speed (RPM)									
	5	10	20	30	35	45	50	60	75	90
2A100, 2A105, 2A110, 2A115, 2A120, 2A125, 2A140, 2A145,	989	989	989	989	989	989	989	989	989	989
2B120, 2B125, 2B140, 2B145, 2B160, 2B165	1641	1641	1641	1641	1641	1641	1641	1641	1641	1641
2C140, 2C145, 2C160, 2C165, 2C170, 2C175	2855	2855	2855	2855	2855	2855	2855	2855	2855	2405
2D160, 2D165, 2D170, 2D175,	3934	3934	3934	3934	3934	3934	3934	3934	3934	3754
2E170, 2E175	4114	4114	4114	4114	4114	4114	4114	4114	4114	4114

Figure 5.7 Input Shaft Load Location Factor

Single Reduction Frame Size	L (inch)											
	1/4	1/2	3/4	1	1 1/4	1 1/2	1 3/4	2	2 1/2	3	3 1/2	4
2A100, 2A105, 2A110, 2A115	0.93	1.09	1.52	2.03	–	–	–	–	–	–	–	–
2A120, 2A125	–	0.87	1.10	1.43	1.77	2.12	–	–	–	–	–	–
2A140, 2A145	–	0.84	0.98	1.25	1.53	1.83	2.11	–	–	–	–	–
2B140, 2B145	–	0.84	0.98	1.25	1.53	1.83	2.11	–	–	–	–	–
2B160, 2B165	–	0.94	0.97	1.06	1.22	1.36	1.51	1.66	–	–	–	–
2C160, 2C165	–	0.94	0.97	1.06	1.22	1.36	1.51	1.66	–	–	–	–
2D160, 2D165	–	0.94	0.97	1.06	1.22	1.36	1.51	1.66	–	–	–	–
2C170, 2C175	–	–	0.95	0.99	1.09	1.23	1.38	1.51	1.79	2.08	–	–
2D170, 2D175	–	–	0.95	0.99	1.09	1.23	1.38	1.51	1.79	2.08	–	–
2E170, 2E175	–	–	0.95	0.99	1.09	1.23	1.38	1.51	1.79	2.08	–	–

Figure 5.8

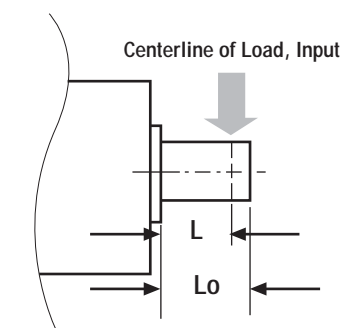

Figure 5.9 Input Shaft Overhung Load Capacity (Lf, Cf, Sf = 1)

Unit: lbs.

Single Reduction Frame Size	Ratio	Input Speed RPM						
		1750	1450	1165	980	870	720	580
2A100, 2A105	11~39, 60~417 46, 53	99	99	110	121	132	132	132
		99	77	99	110	110	121	132
2A110, 2A115	21, 28, 74~305 39~60	99	77	99	110	110	121	132
		44	44	44	44	55	55	66
2A120, 2A125	21~60 74~305	133	155	166	175	198	198	198
		121	99	110	121	133	198	198
2A140, 2A145	21, 28 39~74	308	308	308	342	364	387	418
		277	220	243	265	277	297	330
2B140, 2B145	88	243	254	265	288	297	308	330
		121	133	133	155	155	155	243
2C140, 2C145	102~305	121	133	133	155	155	155	243
		398	398	441	463	486	486	486
2B160, 2B165	28~88, 179, 207	398	398	441	463	486	486	486
		243	265	288	308	308	353	398
2C160, 2C165	102~151, 249, 305	243	265	288	308	308	353	398
		463	463	508	508	528	551	596
2C170, 2C175, 2D170, 2D175, 2E170, 2E175	39~305	463	463	508	508	528	551	596

Cyclo BBB

Appendix

Special Load Guidelines Inertia

Figure 5.10 Moment of Inertia on Motor Shaft of Gearmotor¹

Units: lbs•inch²

Frame Size	Reduction Ratio								
	11	18	21	28	39	46	53	60	74
2A100, 2A105	1.53	0.636	0.461	0.301	0.175	0.162	0.141	0.101	0.104
2A110, 2A115	–	–	0.697	0.485	0.345	0.302	0.276	0.258	0.224
2A120, 2A125	3.59	1.48	1.23	0.960	0.584	0.619	0.581	0.434	0.489
2A140, 2A145	7.59	3.16	3.37	2.27	1.60	1.29	1.16	1.03	0.875
2B120, 2B125	4.99	2.00	1.59	1.16	0.690	0.697	0.636	0.479	0.520
2B140, 2B145	9.06	3.69	3.73	2.47	1.71	1.36	1.22	1.07	0.906
2B160, 2B165	23.0	9.67	8.78	6.08	4.00	3.62	3.28	2.80	2.58
2C140, 2C145	13.2	5.20	4.79	3.06	2.02	1.59	1.38	1.20	0.991
2C160, 2C165	27.2	11.2	9.84	6.70	4.31	3.86	3.45	2.93	2.67
2C170, 2C175	50.2	21.8	23.6	17.4	13.4	12.2	10.8	10.3	9.57
2D160, 2D165	38.6	15.3	12.7	8.3	5.16	4.44	3.90	3.28	2.90
2D170, 2D175	61.5	25.8	26.5	19.0	14.2	12.8	11.2	10.7	9.81
2E170, 2E175	76.9	31.3	30.3	21.2	15.4	13.6	11.8	11.1	10.1

Note: [1] Figure 5.10 does not include the inertia of the integral motors. Total unit inertia is obtained by adding the reducer inertia to the motor inertia.

Frame Size	Reduction Ratio								
	88	102	123	151	179	207	249	305	
2A100, 2A105	0.092	0.064	0.058	0.053	0.070	0.047	0.067	0.045	
2A110, 2A115	0.214	0.206	0.196	0.191	0.185	0.183	0.181	0.179	
2A120, 2A125	0.451	0.318	0.301	0.285	0.393	0.271	0.383	0.260	
2A140, 2A145	0.813	0.745	0.718	0.673	0.656	0.653	0.639	0.632	
2B120, 2B125	0.472	0.333	0.311	0.292	0.400	0.275	0.386	0.262	
2B140, 2B145	0.834	0.759	0.728	0.680	0.660	0.660	0.639	0.636	
2B160, 2B165	2.43	2.17	2.09	2.00	1.97	1.98	1.89	1.87	
2C140, 2C145	0.892	0.803	0.759	0.701	0.677	0.670	0.649	0.639	
2C160, 2C165	2.49	2.21	2.12	2.02	1.99	1.99	1.90	1.87	
2C170, 2C175	9.19	8.75	8.58	8.37	8.27	8.17	8.13	8.10	
2D160, 2D165	2.66	2.33	2.20	2.07	2.02	2.02	1.92	1.88	
2D170, 2D175	9.37	8.89	8.65	8.44	8.31	8.20	8.17	8.10	
2E170, 2E175	9.60	9.06	8.78	8.51	8.37	8.24	8.20	8.13	

Figure 5.11 Moment of Inertia on Motor Shaft of 3-Phase Integral Motor

Units: lbs•inch²

1/8 HP x 4 Pole		1/4 HP x 4 Pole		1/3 HP x 4 pole		1/2 HP x 4 pole		3/4 HP x 4 pole		1 HP x 4 pole	
Standard	w/ Brake	Standard	w/ Brake	Standard	w/ Brake	Standard	w/ Brake	Standard	w/ Brake	Standard	w/ Brake
1.11	1.20	1.71	1.88	1.71	1.88	2.22	2.31	3.45	3.79	4.10	4.44
1/5 HP x 4 Pole		2 HP x 4 Pole		3 HP x 4 pole		5 HP x 4 pole		7.5 HP x 4 pole		10 HP x 4 pole	
Standard	w/ Brake	Standard	w/ Brake	Standard	w/ Brake	Standard	w/ Brake	Standard	w/ Brake	Standard	w/ Brake
6.32	7.11	7.28	8.03	11.4	12.7	29.0	32.7	39.0	42.7	91.6	104
15 HP x 4 Pole		20 HP x 4 Pole		25 HP x 4 pole		30 HP x 4 pole		40 HP x 4 pole		50 HP x 4 pole	
Standard	w/ Brake	Standard	w/ Brake	Standard	w/ Brake	Standard	w/ Brake	Standard	w/ Brake	Standard	w/ Brake
128	140	307	455	769	793	769	793	855	878	1053	1097

Figure 5.12 Moment of Inertia on Motor Shaft of 3 Phase, Inverter Duty, Integral Motor

Units: lbs•inch²

1/8 HP x 4 Pole		1/4 HP x 4 Pole		1/2 HP x 4 pole		1 HP x 4 pole		2 HP x 4 pole		3 HP x 4 pole	
Standard	w/ Brake	Standard	w/ Brake	Standard	w/ Brake	Standard	w/ Brake	Standard	w/ Brake	Standard	w/ Brake
1.71	1.88	2.22	2.31	4.10	4.44	7.28	8.03	11.4	12.7	29.0	32.7
5 HP x 4 Pole		7.5 HP x 4 Pole		10 HP x 4 pole		15 HP x 4 pole		20 HP x 4 pole		25 HP x 4 pole	
Standard	w/ Brake	Standard	w/ Brake	Standard	w/ Brake	Standard	w/ Brake	Standard	w/ Brake	Standard	w/ Brake
39.0	42.7	91.6	104	128	140	307	455	769	-	769	793
30 HP x 4 Pole		40 HP x 4 Pole									
Standard	w/ Brake	Standard	w/ Brake								
855	878	1053	1097								

Cyclo BBB

Appendix

Figure 5.13 Moment of Inertia on High Speed Shaft of Reducer

Units: lbs•inch²

Frame Size	Reduction Ratio								
	11	18	21	28	39	46	53	60	74
2A100, 2A105	1.54	0.649	0.482	0.281	0.196	0.140	0.120	0.125	0.083
2A110, 2A115	—	—	0.718	0.506	0.366	0.323	0.296	0.279	0.244
2A120, 2A125	3.62	1.54	1.35	0.841	0.704	0.499	0.461	0.554	0.369
2A140, 2A145	7.76	3.33	3.73	2.55	1.86	1.51	1.37	1.26	1.09
2B120, 2B125	5.06	2.06	1.71	1.04	0.810	0.578	0.520	0.598	0.400
2B140, 2B145	9.23	3.86	4.07	2.76	1.97	1.59	1.43	1.30	1.12
2B160, 2B165	31.3	18.0	12.9	10.1	8.03	7.66	7.31	6.84	6.63
2C140, 2C145	13.4	5.37	5.13	3.35	2.28	1.81	1.60	1.43	1.20
2C160, 2C165	35.5	19.6	13.9	10.7	8.34	7.90	7.49	6.97	6.70
2C170, 2C175	57.4	29.2	28.0	21.8	17.7	16.5	15.1	14.7	13.8
2D160, 2D165	46.8	27.1	16.7	12.3	9.16	8.48	7.93	7.31	6.94
2D170, 2D175	69.0	33.3	30.8	23.4	18.6	17.2	15.6	15.0	14.1
2E170, 2E175	84.4	39.0	34.5	25.6	19.8	18.0	16.2	15.5	14.4

Frame Size	Reduction Ratio								
	88	102	123	151	179	207	249	305	
2A100, 2A105	0.071	0.085	0.079	0.074	0.049	0.068	0.046	0.066	
2A110, 2A115	0.234	0.227	0.217	0.211	0.205	0.204	0.201	0.200	
2A120, 2A125	0.332	0.438	0.420	0.407	0.275	0.390	0.265	0.379	
2A140, 2A145	1.04	0.964	0.937	0.882	0.875	0.872	0.855	0.851	
2B120, 2B125	0.352	0.451	0.431	0.414	0.280	0.393	0.267	0.383	
2B140, 2B145	1.06	0.978	0.947	0.889	0.878	0.878	0.858	0.851	
2B160, 2B165	6.46	6.19	6.12	6.02	6.02	6.02	5.91	5.91	
2C140, 2C145	1.11	1.03	0.978	0.909	0.892	0.889	0.865	0.855	
2C160, 2C165	6.53	6.25	6.15	6.05	6.02	6.02	5.95	5.91	
2C170, 2C175	13.6	13.1	12.9	12.7	12.6	12.5	12.5	12.4	
2D160, 2D165	6.70	6.36	6.22	6.02	6.05	6.05	5.95	5.91	
2D170, 2D175	13.7	13.2	13.0	12.7	12.6	12.5	12.5	12.4	
2E170, 2E175	13.9	13.4	13.1	12.8	12.7	12.5	12.5	12.4	

Special Load Guidelines Misc.

Excessive Overloads

Cyclo BBB Speed Reducers provide 300% momentary intermittent shock load capacity and are warranted for 2 years from date of shipment. Refer to our standard terms and conditions for our complete warranty.

Selection for Applications Involving Shock Loading

For applications involving frequent start-stop, braking or reversing, or quick starting of load having large inertia, consult factory for model selection or recommended modifications.

Allowable Radial and Thrust Loads

The loads imposed on the slow speed shaft vary with the method of connecting the shaft to the driven machine. Frequently, in addition to torsional forces, radial and thrust loads are applied to the slow speed shaft at the same time. For example, coupling connections normally involve torsional forces only. However, when power is transmitted through spur gears, belts, pulleys or chains, both torsional and radial forces may be applied to the slow speed shaft. When driving through helical or bevel gears, all three conditions (torsional, radial and thrust load) may be referred to the reducer shaft.

The slow speed shaft and bearings must have sufficient strength to withstand these loads, and it is, therefore, necessary to determine the allowable limits for each condition.

Load Centering

The radial load capacities are calculated with the load concentrated at the midpoint of the slow speed shaft extension. Radial load capacities decrease if the center of the load is moved farther from the reducer and the values obtained from the charts must be adjusted accordingly.

Cyclo BBB

Taper Grip® Bushing

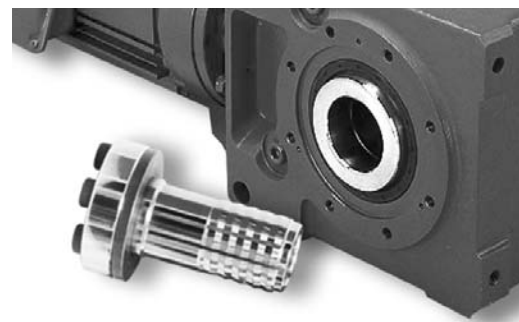

NOTE: Similar to all shrink disk type devices. It is essential to properly assemble and tighten the mounting bolts. Carefully follow the Sumitomo instructions for selection and installation in order to avoid any slippage. Incorrect mounting or slippage of the bushing will impair function and removal of the drive.

Fitting the Reducer on the Shaft

1. Check the size and condition of the shaft to which the reducer will be fitted. Permissible shaft tolerances are given in Figure 5.14.
2. Ensure all mating surfaces of the hub, the inside and outside diameters of the Taper-Grip® bushing and the shaft are free from burrs and corrosion. Clean each surface with a solvent to REMOVE ALL TRACES OF GREASE AND OIL.
3. Lightly oil each screw and insert into the bushing flange; ensure they do not protrude beyond the rear face.
4. Slide the thrust collar onto the Taper-Grip® bushing, ensuring that it is located immediately behind the flange. Screw the Taper-Grip® bushing into the hub in a clockwise direction until the flange contacts the thrust collar.
5. Unscrew the Taper-Grip® bushing until a gap of 1mm minimum exists between the flange and thrust collar. Tighten all screws until they are finger tight.
6. Slide the reducer onto the shaft at least as far as the counter bore in the Taper-Grip® bushing. Gradually tighten each screw in a star pattern to the torque levels shown in Figure 5.15.
7. Install the torque arm assembly if one is used.
8. After mounting is complete, the Cyclo BBB can then be filled with oil. Please follow proper guidelines for oil lubrication. Grease lubricated units are pre-filled at the factory.

For complete details regarding Cyclo BBB mounting, including bushing type, keyed hollow-shaft type, torque arm and lubrication, please refer to the appropriate sections in the Cyclo BBB O & M Manual.

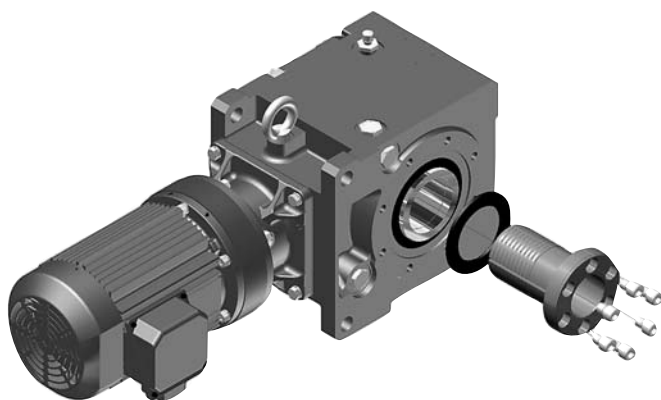

Figure 5.14 PERMISSIBLE SHAFT TOLERANCE

Shaft Dia.	Tolerance
$3\frac{1}{44}'' - 1\frac{1}{48}''$	+0 - .005"
$1\frac{3}{416}'' - 2''$	+0 - .006"
$2\frac{1}{416}'' - 3\frac{1}{48}''$	+0 - .007"
$3\frac{3}{416}'' - 4\frac{3}{44}''$	+0 - .008"

NOTE: Shaft runout TIR should be no greater than .001".

Figure 5.15 BUSHING SCREW TIGHTENING TORQUES

Size	Screw Size Qty. & Code	Screw Torque lb. ft.
A	6 X M12 112E7003	56
B	6 X M12 112E7003	104
C	6 X M16 112G7003	185
D	6 X M16 112G7003	223
E	8 X M16 112G7003	223

Figure 5.16 BUSHING BORE TOLERANCES

Inch	Tolerance	Metric mm	Tolerance*
$1\frac{11}{416} - 1\frac{15}{416}$	+ .003 / .001	40-50	.064 / .025
$2 - 2\frac{7}{416}$	+ .003 / .001	50-65	.076 / .030
$2\frac{1}{42} - 3\frac{7}{416}$	+ .003 / .001	65-80	.076 / .030
$3\frac{1}{42} - 3\frac{15}{416}$	+ .003 / .001	80-100	.090 / .036

*Metric Tolerances are F8.

Cyclo BBB

Appendix

Parts List

General Construction Bevel Gear Case

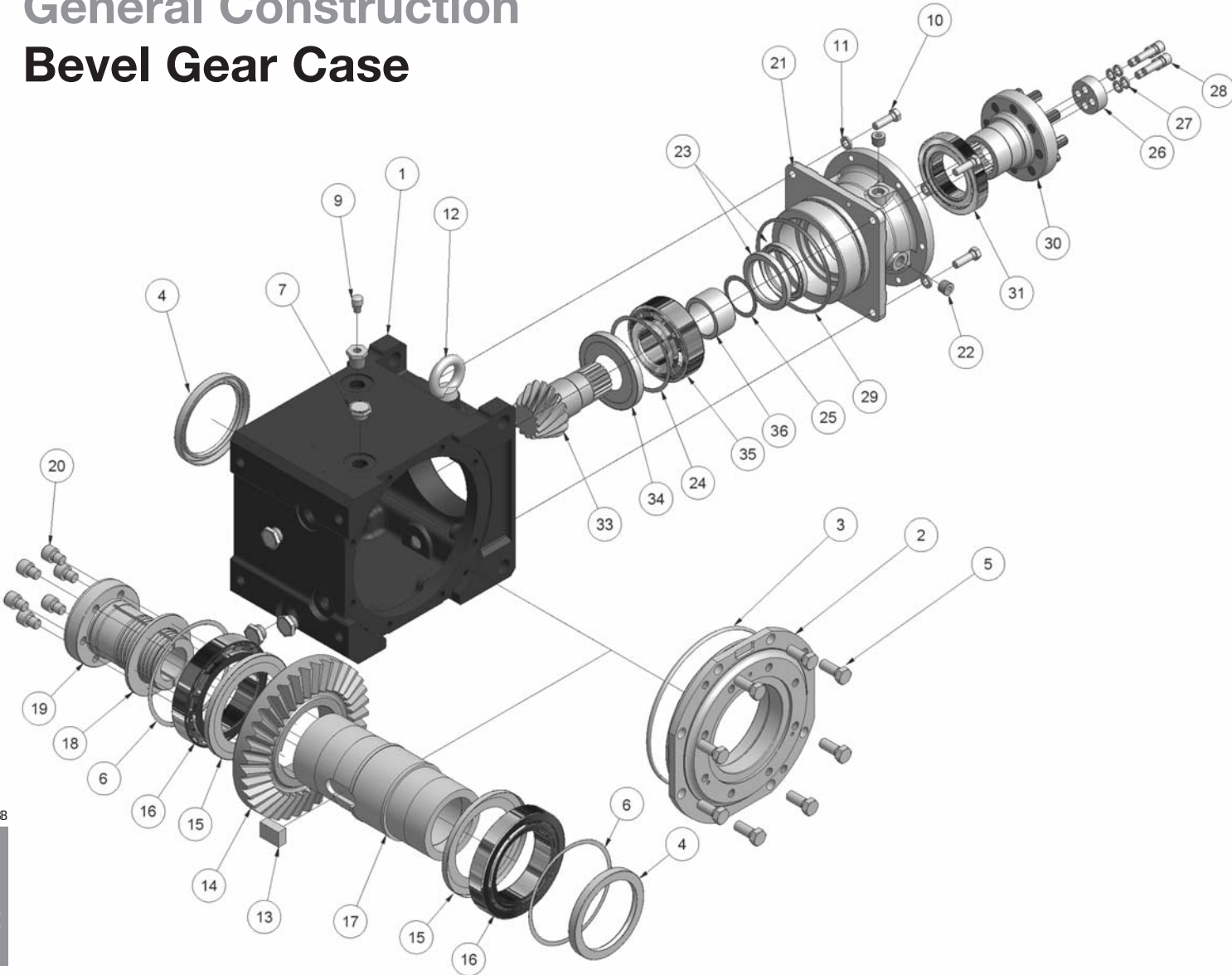

Cyclo BBB

Appendix

FIGURE 5.17 Parts Code Numbers

Item No.	Description	QTY	Unit Size				
			A	B	C	D	E
1	Gear Housing	1	AE693LG	AE774LG	AE695LG	AE696LG	AE697LG
2	Output Cover	1	BL520LG	BL531LG	BL542LG	BL550LG	BL554LG
3	O-Ring	1	540NG1701-A-G	540NG2101-A-G	540NG2601-A-G	541N5.7-3258G	541N5.7-3757G
4	Oil Seal	2	531N8511013-G	531N10012513G	531N12015014G	531N14017014G	531N16019016G
5	Hex Head Bolt	8	001M010R030NG	001M012R030NG	001M016R040NG	001M020R050NG	001M020R050NG
6[2]	Shim	Varies	As required	As required	As required	As required	As required
7	Plug	8	343C008R- - -NG	343C008R- - -NG	343C012R- - -NG	343C012R- - -NG	343C012R- - -NG
8	Bushing	1	332F008R004NG	332F008R004NG	332F012R004NG	332F012R004NG	332F012R004NG
9	Air Vent	1	DT206LG	DT206LG	DT206LG	DT206LG	DT206LG
10	Hex Head Bolt	4	001M010R030NG	001M010R030NG	001M012R040NG	001M016R050NG	001M016R050NG
11	Spring Washer	4	062W010- - -NG	062W010- - -NG	062W012- - -NG	062W016- - -NG	062W016- - -NG
12	Eye Bolt	1	006C016R- - -NG	006C016R- - -NG	006C020R- - -NG	006C020R- - -NG	006C024R- - -NG
13	Key	1	233M2214021NG	233M2514028NG	233M2816040NG	233M3218050NG	233M3620060NG
14	Bevel Gear	1	AP0646G	AP0647G	AP0648G	AP0649G	AP0650G
15	Nilos Ring	2	50532017XAV-G	50532020XAV-G	50532024XAV-G	50532028XAV-G	50532032XAV-G
16	Tapered Roller Bearing	2	503T32017XU-G	503T32020XU-G	503T32024XU-G	503T32028XU-G	503T32032XU-G
17	Taper-Grip® Output Hub	1	BL937LG	BL938LG	BL939LG	BL940LG	BL941LG
18[3]	Thrust Plate	1	—	—	—	—	—
19	Taper-Grip® Bushing	1	As required	As required	As required	As required	As required
20[3]	Taper-Grip® Bushing Screws	Varies	—	—	—	—	—
21[4]	Flanged Casing	1	As required	As required	As required	As required	As required
22	Hex Socket Plug	Varies	As required	343C008R- - -NG	343C008R- - -NG	343C008R- - -NG	343C008R- - -NG
23	Oil Seal	2	530N50689- - -G	530N60759- - -G	530N709513- -G	530N9011513-G	530N9011513-G
24[2]	Shim	Varies	As required	As required	As required	As required	As required
25[2]	Shim	Varies	As required	As required	As required	As required	As required
26	End Plate	1	AW7028G	AW7030G	AW7032G	As required	AW7036G
27	Lock Washer	4	EU593WW-05	EU593WW-05	EU593WW-07	As required	EU593WW-09
28	Hex. Soc. Hd. Cap Screw	4	009M008R030NG	009M010R035NG	009M012R040NG	As required	009M016R055NG
29	O-Ring	1	540NG1101-A-G	540NG1301-A-G	540NG1501-A-G	540NG1751-A-G	540NG1851-A-G
30[5]	Pin Carrier	1	As required	As required	As required	As required	As required
31	Tapered Roller Bearing	1	As required	As required	As required	As required	As required
33	Bevel Pinion Shaft	1	BL513LG	BL525LG	BL536LG	As required	BL553LG
34	Nilos Ring	1	50532308AV- -G	50532310AV- -G	50532312AV- -G	50532314AV- -G	50532315AV- -G
35	Tapered Roller Bearing	1	503T32308U- -G	503T32310U- -G	503T32312U- -G	503T32314U- -G	503T32315U- -G
36	Collar	1	AW7027G	AW7029G	AW7031G	As required	AW7034G

- Notes: [1] When ordering replacement parts, please indicate the complete unit model number, ratio and serial number.
 [2] Shims are not available individually. They may be ordered as a complete set only.
 [3] Item Numbers 18 and 20 are not available as individual parts. They come complete with the Taper-Grip® Bushing.
 [4] The Flange Casing is determined based on the associated input Cyclo size.
 [5] Item Numbers 30 and 32 are available together as a complete subassembly only.

Cyclo Parts List

Cyclo Reducer Input Section

Single Reduction

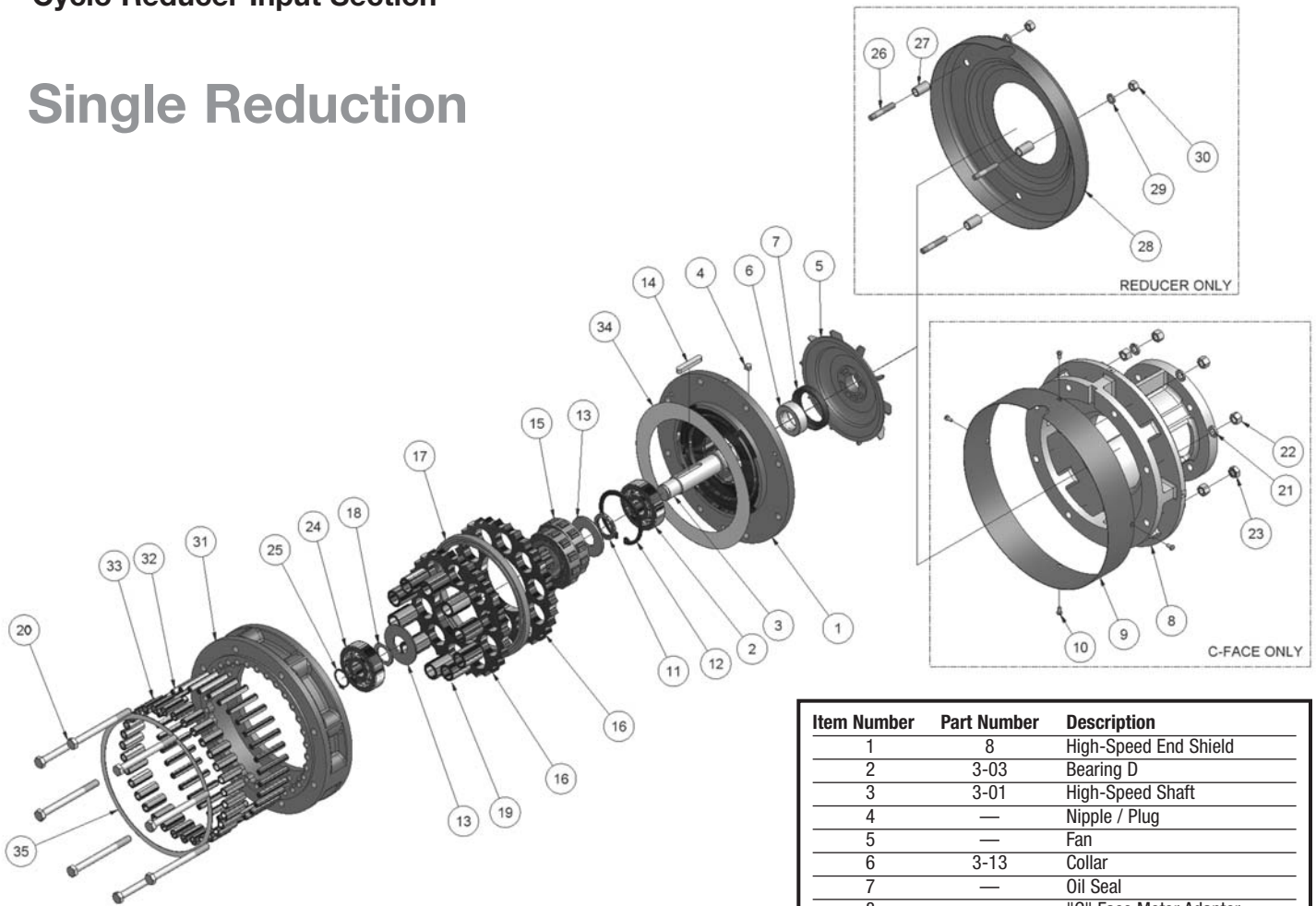

Figure 5.18 Main Parts

Item Number	Part Number	Description
1	8	High-Speed End Shield
2	3-03	Bearing D
3	3-01	High-Speed Shaft
4	—	Nipple / Plug
5	—	Fan
6	3-13	Collar
7	—	Oil Seal
8	—	"C" Face Motor Adapter
9	—	Fan Shroud
10	—	Shroud Bolts/Screws
11	3-08	Spacer
12	3-11	Snap Ring
13	—	Endplate
14	3-05	Eccentric Key
15	3-04	Eccentric Cam Assembly
16	2-04	Cycloid Discs
17	2-05	Disc Spacer
18	3-09	Spacer
19	—	Slow Speed Shaft Rollers
20	—	Housing Bolts
21	—	Washers
22	—	Nuts
23	—	Locknut
24	3-02	Bearing C
25	3-10	Snap Ring
26	—	Tap-End Stud
27	—	Fan Spacer
28	—	Fan Cover
29	—	Washers
30	—	Nuts
31	2-01	Ring Gear Housing
32	2-02	Ring Gear Pins
33	2-03	Ring Gear Rollers
34	—	Gasket*
35	—	Gasket*

*Supplied as a set only

Cyclo BBB

Appendix

Cyclo Reducer Input Section

Double Reduction

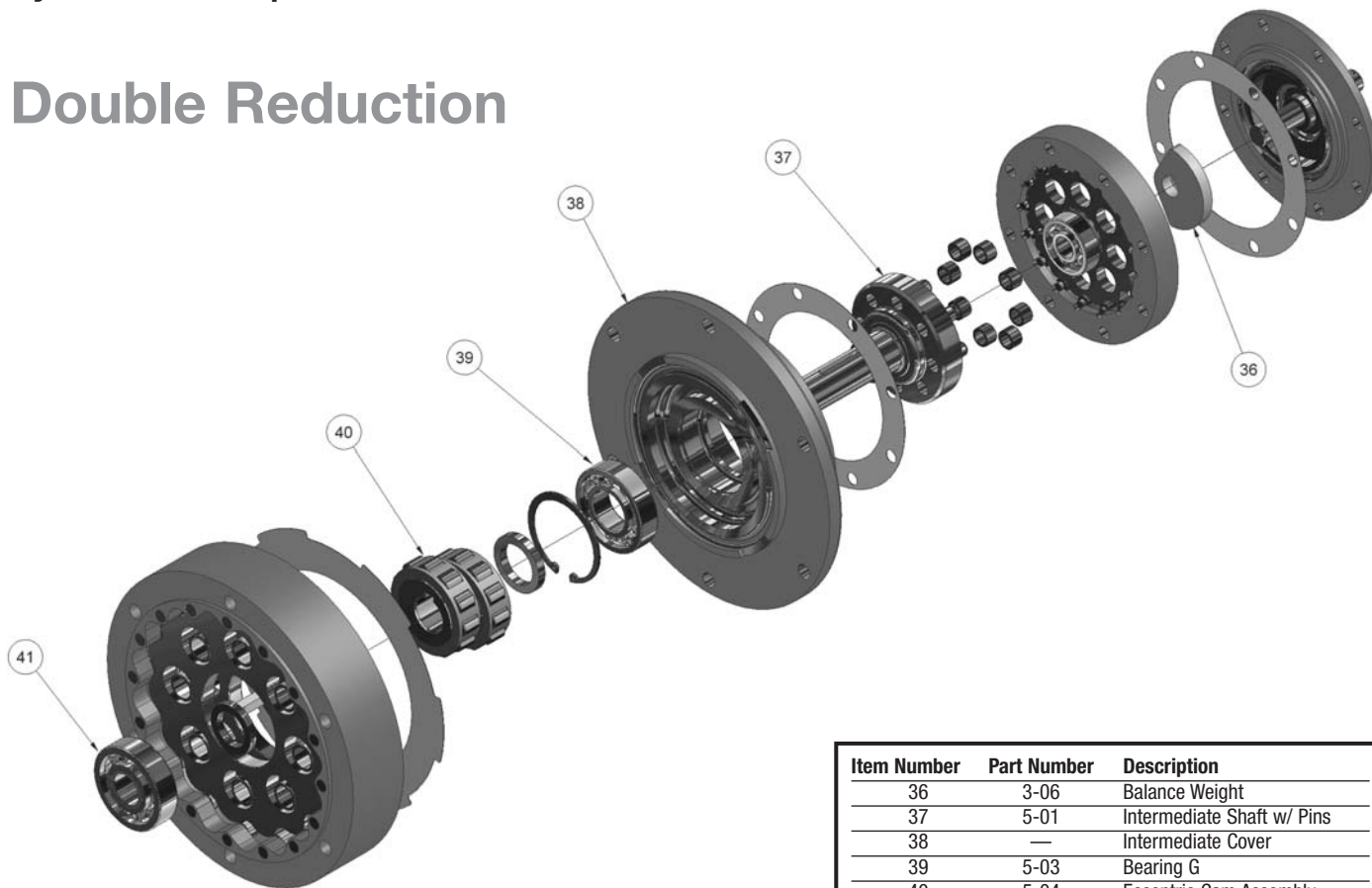

Item Number	Part Number	Description
36	3-06	Balance Weight
37	5-01	Intermediate Shaft w/ Pins
38	—	Intermediate Cover
39	5-03	Bearing G
40	5-04	Eccentric Cam Assembly
41	5-02	Bearing F

NOTE: The parts listed are a general representation of the components found in a single and double reduction Cyclo.

Specific units may or may not contain all shown here.

Please consult the factory for specific part questions.

Standard Motor Characteristics

Motor Characteristics

The Cyclo® BBB gearmotors full load ratings and amperage can be found below in Figure 5.19. These ratings are based on the motor's design values. If additional information is required, please consult factory.

Figure 5.19 230/460 Volt, Synchronous Speed 1800 rpm, 60 Hz, Continuous Duty, TEFC

HP	Frame Size	Full Load rpm	Full Load Torque in. lb.	Full Load Current Amperage			Starting Current Amperage		Torque % of F.L. Break-down		Efficiency %	Power Factor %	Code Letter*	Inertia WR ² lb. ft ²
				230V	460V	208V	230V	460V	Starting	Break-down				
1/2	F-71M	1740	18.3	2.1	1.1	2.0	9.8	4.9	295	280	71.9	65.1	J	0.0154
3/4	F-80S	1730	27.4	2.5	1.2	2.5	12.3	6.2	266	245	76.9	73.0	H	0.0227
1	F-80	1750	36.0	3.4	1.7	3.4	17.6	8.8	269	303	77.2	72.3	H	0.0285
1.5	F-90S	1730	54.7	4.6	2.3	4.7	28.6	14.3	273	281	80.3	74.1	J	0.0451
2	F-90L	1740	72.5	6.0	3.0	6.2	36.8	18.4	263	270	82.3	75.6	J	0.0504
3	F-100L	1730	109	8.4	4.2	8.7	54.8	27.4	277	266	84.4	77.2	J	0.0789
5	F-112M	1730	183	13.0	6.5	13.7	91.5	45.8	308	279	86.3	82.4	K	0.201
7.5	F-132S	1710	277	18.1	9.0	20.1	120	61	223	221	86.7	88.2	H	0.271
10	F-132M	1740	361	23.6	11.8	26.4	147	73.5	212	214	89.6	88.9	G	0.635
15	F-160M	1740	542	34.3	17.2	38.2	231	115	248	221	90.5	89.0	G	0.891
20	G-160L	1740	725	45.8	22.9	51	272	136	222	220	91.6	89.9	F	2.13
25	G-180M	1770	891	57	28.4	63	343	171	199	235	92.6	88.2	F	5.34
30	G-180M	1760	1075	68	34.2	77	388	194	192	226	91.5	88.1	F	5.34

*Code letter shown is for 230V or 460V operation. Consult factory for other voltages.

Standard Wiring Diagram – 208, 230/460V

Illustrated below are the wiring diagrams for our standard motor. For additional information please refer to motor name plate. Due to changes in design features, this diagram may not always agree with that on the motor. If different, the motor diagram found inside the conduit box cover is correct.

Cyclo BBB

Appendix

Figure 5.20 Y-Connected (5 HP and smaller)

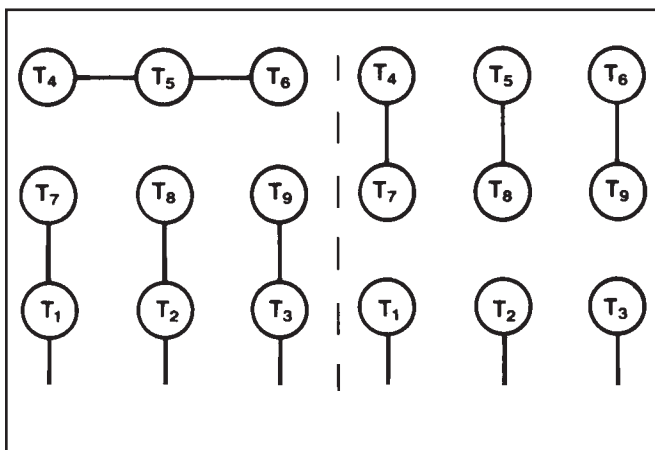

Line 208/230V 60Hz

Line 460V 60Hz

Figure 5.21 Delta-Connected (7 1/2 HP and larger)

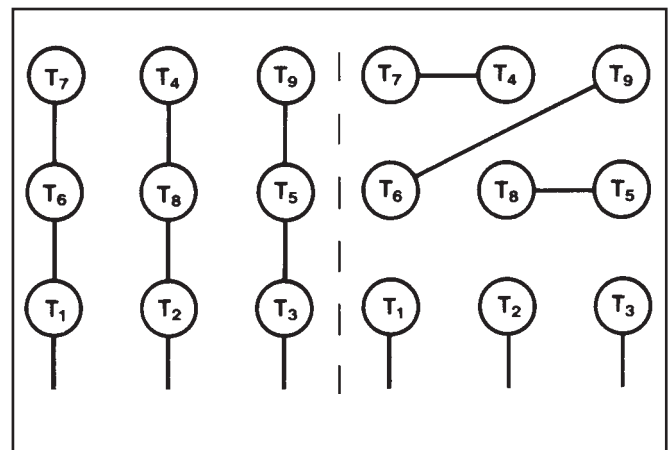

Line 208/230V 60Hz

Line 460V 60Hz

Brakemotor Characteristics

The brakemotor on Cyclo® BBB gearmotors operates on a D.C. current supplied by a dual voltage rectifier mounted on the motor conduit box.

The standard brake input voltage is 208V OR 230V OR 460V at 60 Hz. (For other available voltages consult factory.)

Our standard brakemotor when used for outdoor installations must be protected with some type of covering. Such coverings are available from the factory, please inquire when ordering.

Note: While the brake torque can be field adjusted within a limited range, if you require larger or smaller brake torque than those listed, please advise the factory when ordering.

Figure 5.22 Required Brake Response Action

Condition	% Motor Torque Rating	Typical Application	Remarks
Rapid Brake Action	100%	Machine Tool Cutter and Table Transfer	
Frequent Start/Stop	100%	Conveyor Drive	Fast Brake Action May Be Required
Rapid Braking and Fail Safe	Over 150%	Crane, Hoist Winch, Gate, Lifting	Wiring Connection for Fast Brake Action Required
Rapid Deceleration of High Inertia	Over 150%	Centrifuge Drive Textile	

Figure 5.23 Brake Torque

HP	TYPE		BRAKE Torque ft. lb.		Inertia WR ² lb.ft ²	Brake Delay Time (sec)		Coil Current AC Amperage		
	Motor Frame	Brake Model	Std.	Max.		Normal Braking Action	Fast Braking Action	230V	460V	208V
1/8	F-63S	FB-01A	0.7	1.0	0.0083	0.15 ~ 0.2	0.015 ~ 0.02	0.06	0.04	0.06
1/4	F-63M	FB-02A	1.4	2.0	0.0131	0.15 ~ 0.2	0.015 ~ 0.02	0.1	0.06	0.1
1/3	F-63M	FB-02A	1.4	2.9	0.0131	0.15 ~ 0.2	0.015 ~ 0.02	0.1	0.06	0.1
1/2	F-71M	FB-05A	2.9	2.9	0.016	0.1 ~ 0.15	0.01 ~ 0.015	0.1	0.06	0.1
3/4	F-80S	FB-1B	5.8	7.7	0.0267	0.2 ~ 0.3	0.01 ~ 0.02	0.1	0.1	0.1
1	F-80M	FB-1B	5.8	7.7	0.0308	0.2 ~ 0.3	0.01 ~ 0.02	0.1	0.1	0.1
1.5	F-90S	FB-2B	11	14	0.0510	0.2 ~ 0.3	0.01 ~ 0.02	0.3	0.2	0.3
2	F-90L	FB-2B	11	14	0.0564	0.2 ~ 0.3	0.01 ~ 0.02	0.3	0.2	0.3
3	F-100L	FB-3B	16	21	0.0884	0.3 ~ 0.4	0.02 ~ 0.03	0.4	0.2	0.4
5	F-112M	FB-5B	27	36	0.239	0.4 ~ 0.5	0.02 ~ 0.03	0.5	0.3	0.4
7.5	F-132S	FB-8B	40	53	0.309	0.3 ~ 0.4	0.02 ~ 0.03	0.5	0.3	0.4
10	F-132M	FB-10B	54	72	0.736	0.7 ~ 0.8	0.04 ~ 0.05	0.8	0.5	0.7
15	F-160M	FB-15B	80	80	0.991	0.5 ~ 0.6	0.04 ~ 0.05	0.8	0.5	0.7
20	G-160L	CMB-20	72	80	3.150	0.6 ~ 0.8	0.1 ~ 0.15	1.7	1.9	1.5

Figure 5.24 Rectifier

BRAKE TYPE	MOTOR (HP X P)	VOLTAGE (V)	RECTIFIER P.N. SINGLE VOLTAGE (SEE NOTE BELOW)	BRAKE TYPE	MOTOR (HP X P)	VOLTAGE (V)	RECTIFIER P.N. SINGLE VOLTAGE (SEE NOTE BELOW)
FB-01A	1/8 x 4	190 ~ 230 380 ~ 460	25FW-4FB	FB-5B	5 x 4	190 ~ 230 380 ~ 460	25FW-4FB
FB-02A	1/4 x 4 1/3 x 4	190 ~ 230 380 ~ 460	25FW-4FB	FB-8B	7.5 x 4	190 ~ 230 380 ~ 460	25FW-4FB
FB-05A	1/2 x 4	190 ~ 230 380 ~ 460	25FW-4FB	FB-10B	10 x 4	190 ~ 230 380 ~ 460	25FW-4FB
FB-1B	3/4 x 4 1/4 x 4	190 ~ 230 380 ~ 460	25FW-4FB	FB-15B	15 x 4	190 ~ 230 380 ~ 460	25FW-4FB
FB-2B	1.5 x 4 2 x 4	190 ~ 230 380 ~ 460	25FW-4FB	CMB-20	20 x 4	180 ~ 460	SB25F-3HS
FB-3B	3 x 4	190 ~ 230 380 ~ 460	25FW-4FB				

NOTE: Dual Voltage Rectifier P.N. 25FW-4FB is now standard for all FB brakes. The voltage range is 190 ~ 460 V.

Brakemotor Characteristics: Wiring

Typical Brakemotor Wiring

Illustrated below is a typical brakemotor wiring schematic. Note the rectifier shown is supplied in the motor conduit box. Due to changes in design features, this diagram may not always agree with that on the motor. If different, the motor diagram found inside the conduit box cover is correct.

Figure 5.25

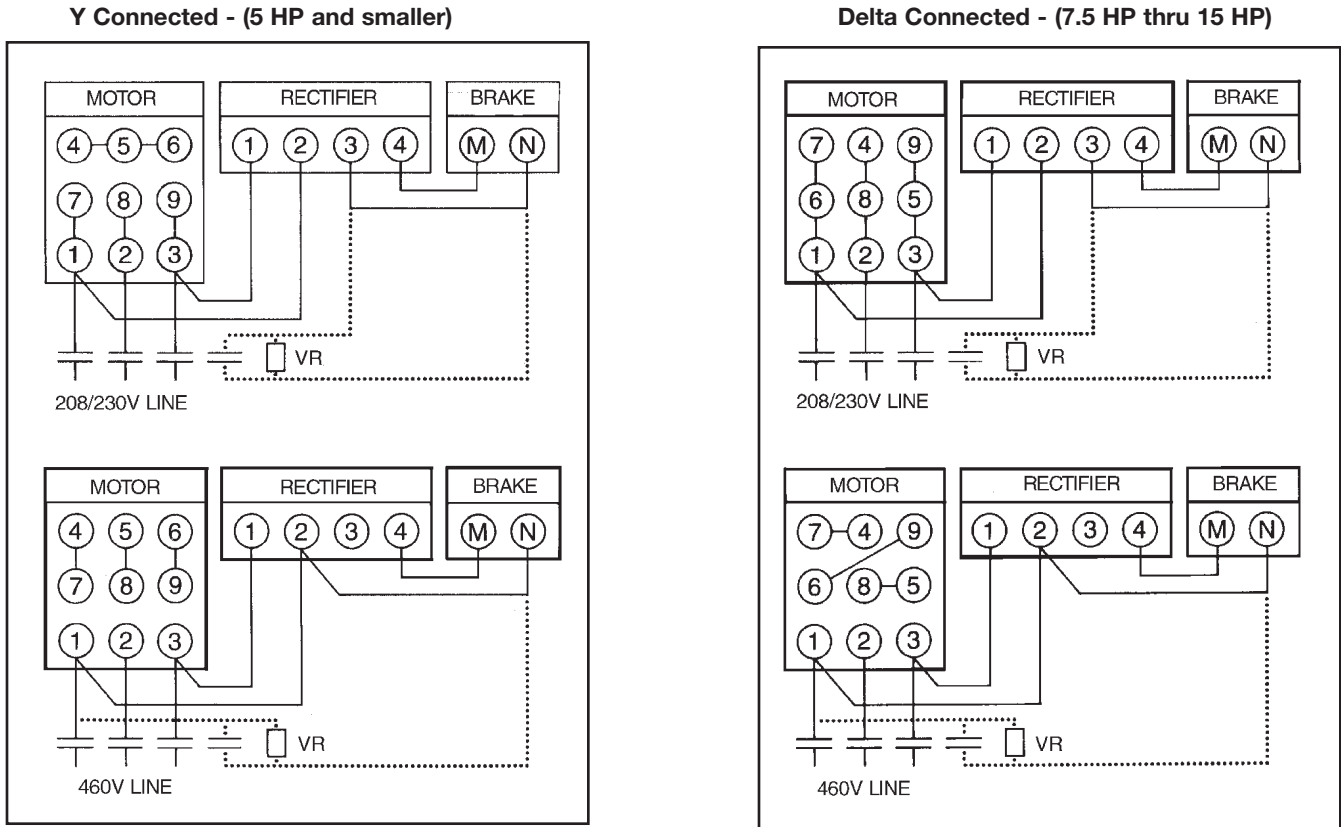

- New dual voltage rectifier can be wired for 230V or 460V supply.
- Solid lines show the wiring connections for standard brake action.
- For fast brake action connect terminals as indicated by dotted lines. Add an additional contactor, and varistor VR from Figure 5.26 below. Do not connect terminal N on brake coil to terminal 3 on rectifier for fast brake action. For 460V fast action braking do not connect terminal N on brake coil to terminal 2 on rectifier.

Cyclo BBB

Appendix

Figure 5.26 Varistors for Fast Braking Action

OPERATING VOLTAGE		208 V / 230 V	460 V	575 V
Varistor Rated Voltage		AC260 ~ 300 V	AC510 V	AC604 V
Varistor Voltage		430 ~ 470 V	820 V	1000 V
Varistor Rated Wattage	FB-01A, 02A, 05A	Over 0.2 W	Over 0.4 W	Over 0.4 W
	FB-1A	Over 0.4 W	Over 0.6 W	Over 0.6 W
	FB-2A, 3A, 5A, 8A	Over 0.6 W	Over 1.5 W	Over 1.5 W
	FB-10A, 15A	Over 1 W	Over 1.5 W	Over 1.5 W

- Please refer to page 5.13, Figure 5.24 for rectifier data.

Standard Wiring Connection

Quick Brake Relay Equipped Models (1/8 to 7.5 HP)

Figure 5.27 Quick Brake Action, Low Voltage (FB-05A, FB-1B, FB-2B, FB-3B)

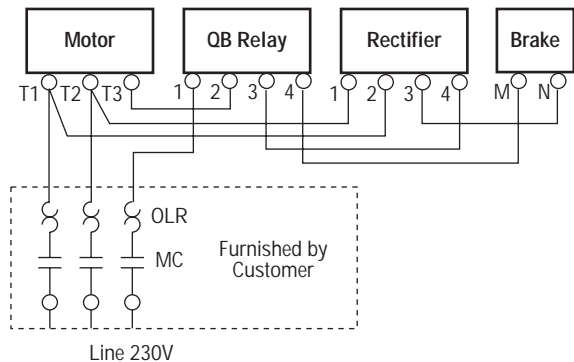
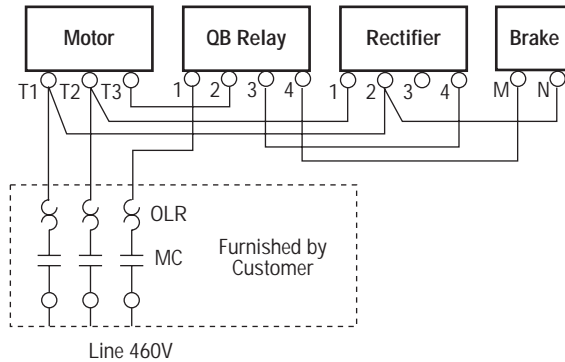

Figure 5.28 Quick Brake Action, High Voltage (FB-2B, FB-3B, FB-5B, FB-8B)



FB Brake (1/8 to 7.5 HP) with Inverter

Figure 5.29 Normal Brake Action, Low Voltage

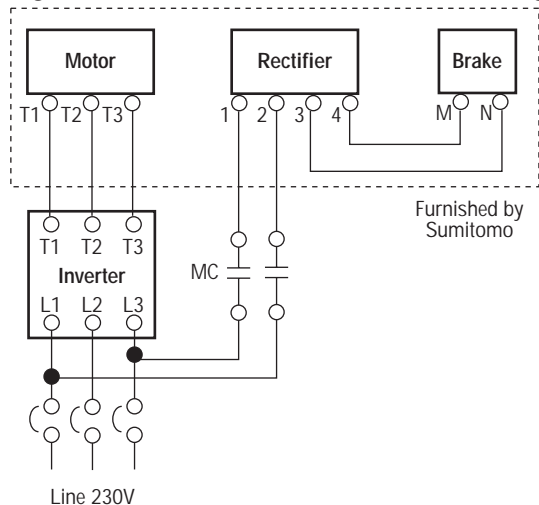

Figure 5.30 Fast Brake Action, Low Voltage

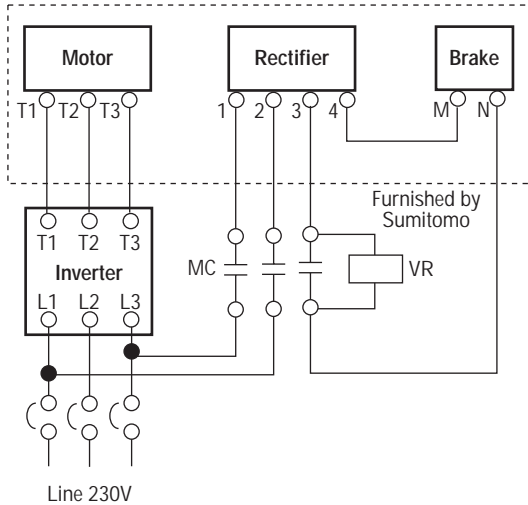

Figure 5.31 Normal Brake Action, High Voltage

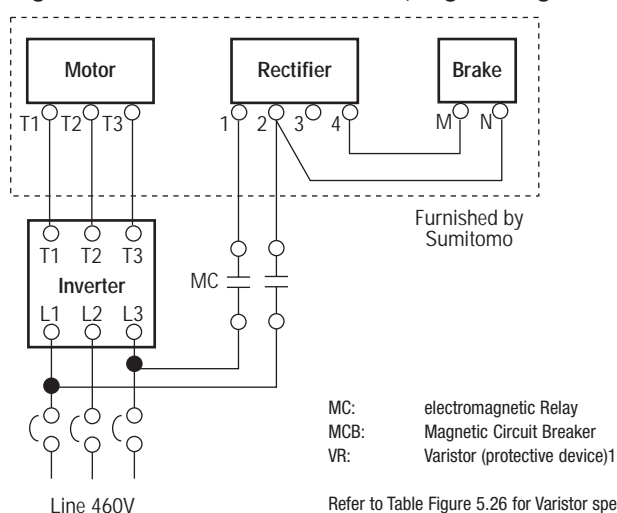
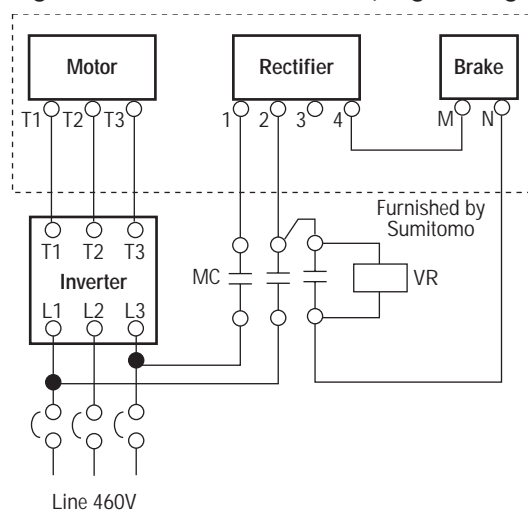

Figure 5.32 Fast Brake Action, High Voltage



MC: electromagnet Relay
 MCB: Magnetic Circuit Breaker
 VR: Varistor (protective device)¹

Refer to Table Figure 5.26 for Varistor specifications

Lubrication

Oil lubricated models are not filled with oil prior to shipping.

Before operating, fill the unit with the appropriate amount of the correct lubricant for the mounting position (see Figure 5.34 and 5.36). When operating in winter or other relatively low ambient temperatures, use the lower viscosity oil specified for each ambient temperature range. Please consult the factory if the unit will be operated consistently in ambient temperatures other than 32°F–104°F.

Grease lubricated models are lubricated with grease prior to shipment from the factory.

Adding grease prior to initial start-up is not required. If grease must be replenished or changed (see Grease Lubrication section), avoid using greases other than those shown in the Table Figure 5.34. Please consult the factory when the units will be used in widely fluctuating temperatures, ambient temperatures other than those specified in Figure 5.35, or when other special conditions exist for the application. When motors from another manufacturer will be used, please consult and adhere to the associated motor maintenance manual for the appropriate lubrication instructions.

Figure 5.33 Lubrication Type Per Unit Size

Unit Size	Output (Gear Side)	Input (Cyclo Side)	
		Motor Horizontal	Motor Vertical
2A100, 2A105, 2A110, 2A115 2A120, 2A125, 2B120, 2B125	Oil Bath	Grease	Grease
2A140, 2A145 2B140, 2B145, 2C140, 2C145, 2B160, 2B165, 2C160, 2C165, 2D160, 2D165, 2C170, 2C175, 2D170, 2D175 2E170, 2E175		Oil Bath	

Figure 5.34 Standard Oils

Ambient Temperature (°F)	ChevronTexaco	Exxon Oil	Mobil Oil	Shell Oil	BP Oil
14 to 41°	EP Gear Compound 68	Spartan EP 68	Mobilgear 626 (ISO VG 68)	Omala Oil 68	Energol GR-XP 68
32 to 95°	EP Gear Compound 100, 150	Spartan EP 100 EP 150	Mobilgear 627, 629 (ISO VG 100, 150)	Omala Oil 100, 150	Energol GR-XP 100 GR-XP 150
86 to 122°	EP Gear Compound 220, 320, 460	Spartan EP 220 EP 320 EP 460	Mobilgear 630, 632 633, 634 (ISO VG 220–460)	Omala Oil 220, 320 460	Energol GR-XP 220 GR-XP 320 GR-XP 460

Figure 5.35 Standard Greases

Ambient Temperature (°F)	Reduction Ratio	Input (Cyclo Side)	Sumitomo Manufactured Motor Open Bearing	
			B Type Insulation	F Type Insulation
14 to 122°	11, 18:1	Shell Alvania EP R0	Shell Alvania Grease #2	Shell Darina Grease #2
	21:1 and higher	Shell Alvania Grease #2		

Figure 5.36 Oil Plug Locations

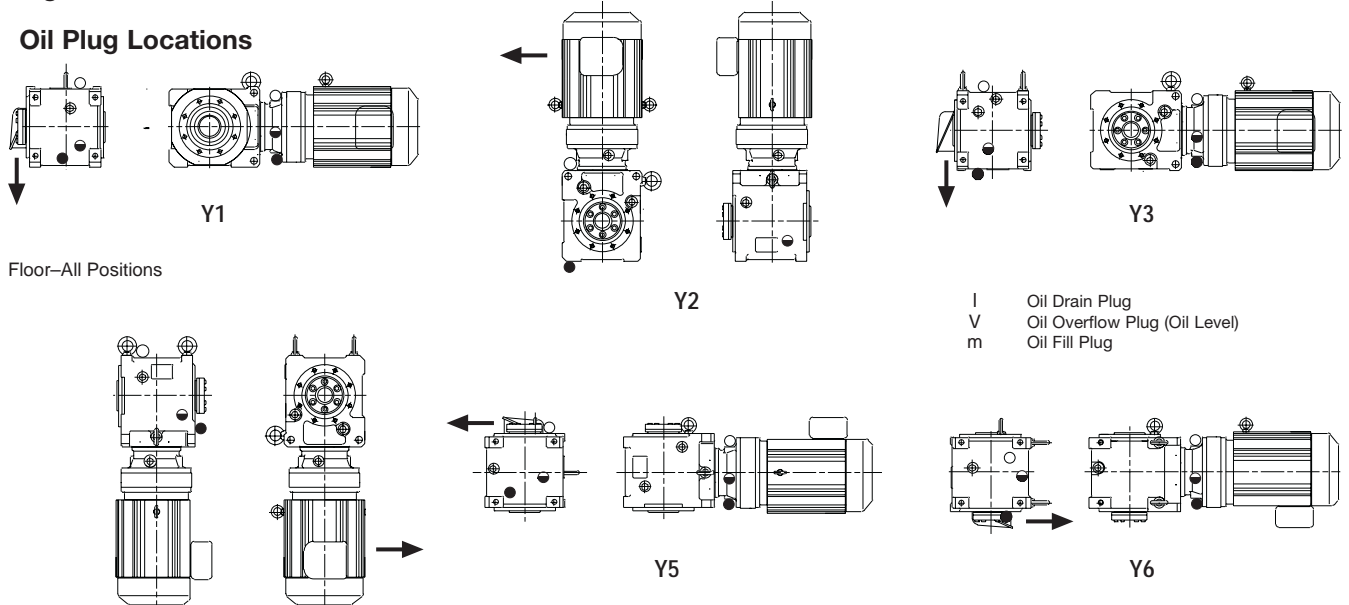

Figure 5.37 Oil Fill Quantities Unit: U.S. Gallons

*G = Grease

Frame Size	Mounting Configuration											
	Y1		Y2		Y3		Y4		Y5		Y6	
	Output	Input*	Output	Input*	Output	Input*	Output	Input*	Output	Input*	Output	Input*
2A100, 2A105		G		G		G		G		G		G
2A110, 2A115	0.29	G	0.26	G	0.29	G	0.26	G	0.45	G	0.42	G
2A120, 2A125		G		G		G		G		G		G
2A140, 2A145		0.08		G		0.08		G		0.08		0.08
2B120, 2B125		G		G		G		G		G		G
2B140, 2B145	0.48	0.12	0.37	G	0.48	0.12	0.48	G	0.61	0.12	0.66	0.12
2B160, 2B165		0.20		G		0.20		G		0.20		0.20
2C140, 2C145		0.12		G		0.12		G		0.12		0.12
2C160, 2C165	0.87	0.20	0.92	G	0.87	0.20	1.16	G	0.95	0.20	1.4	0.20
2C170, 2C175		0.28		G		0.28		G		0.28		0.28
2D160, 2D165		0.18		G		0.18		G		0.18		0.18
2D170, 2D175	1.16	0.24	1.32	G	1.16	0.24	1.11	G	1.48	0.24	1.59	0.24
2E170, 2E175	1.95	0.24	1.93	G	1.95	0.24	1.59	G	1.90	0.24	2.80	0.24

Oil lubricated units are shipped without oil. Prior to initial start-up, the unit must be filled with the correct amount of oil (see Figure 5.37). For those units where both the gear and Cyclo® portions are oil lubricated, the oil must be filled in two separate locations, one on the gear housing and one on the Cyclo® housing.

Grease lubricated models are lubricated at the factory. Additional grease does not need to be added prior to initial start-up.

Oil Replenishment and Change Interval

- Maintain proper oil levels at all times.
- An oil change after the first 500 hours of operation is highly recommended.
- Sumitomo recommends an oil change every 2500 hours, or six months, whichever comes first. If a proper preventive maintenance program is implemented and maintained, a longer change period may be acceptable.
- If the unit is running in a high ambient, high humidity, or corrosive environment, the lubricant will have to be changed more frequently. Consult the factory for recommendations.
- Note: The Cyclo® portion and Bevel portion, where applicable, must be filled with oil separately. Oil does not flow from one section to the other.

Grease Replenishment and Change Interval

- On single reduction Cyclo® Bevel Buddybox (Cyclo® BBB) sizes 2A100~125 and 2B120~125, the Cyclo® portion is grease lubricated as standard and therefore maintenance free. Consult the operations and maintenance manual for the grease change interval.
- When mounting Cyclo® BBB sizes 2A140~145, 2B140~145, 2B160~165, and all sizes of 2C, 2D, and 2E in the Y2 and Y4 positions, please consult the maintenance and operations manual for the proper grease replenishment and change interval for the Cyclo® portion.

Cyclo BBB

Appendix

Installation

Shaft Connections

Pulley, sprocket or sheave connection – When using any of these connections, mount as close to the unit housing as possible, never beyond the midpoint of the shaft projection, to avoid undue bearing load and shaft deflection. Never overtighten belts or chains. Careful and accurate installation is essential for best results and for trouble-free operation. Before installing, the shafts should be checked to make sure that they are parallel and level. Perfect alignment after mounting can be checked with a string or straight edge held against the sides of the sprocket or pulley base.

Couplings should be properly aligned to the limits specified by the manufacturer. On coupled speed reducers coupling alignment should be checked prior to initial startup.

Shaft Rotation

On single reduction Cyclo® BBB speed reducers, ratios 11 through 305, the slow speed shaft rotates in a reverse direction to that of the high speed shaft.

On double reduction units, ratios 357 through 26,492, both the high speed and the slow speed shaft rotate in the same direction.

Input Speeds

In general terms, the standard input speeds of single reduction units are 1750 and 1165 RPM.

When non-standard input speeds are used, the horsepower and torque ratings will also vary.

Thermal Capacity

The Cyclo® BBB speed reducer's smooth, almost frictionless operation all but eliminates the conventional limitations due to heat. In all sizes, Cyclo® BBB speed reducers have thermal ratings that exceed their mechanical capacity.

Mounting Tips

Horizontal and vertical oil-lubricated units should be mounted in exact planes whenever possible. When they are mounted on inclined surfaces, minor modifications are necessary, since an inclined mounting could lower the oil to a level that will starve reduction parts and bearings. On the other hand, overfilling a unit with oil may cause leakage through the air vent, foaming and churning and consequently overheating. Any of the above could result in damage to the unit. In many cases we can provide grease lubrication to solve this problem.

Installation

Be sure to install and operate Cyclo® BBB speed reducers in compliance with applicable local and national safety codes. Appropriate guards for rotating shafts should be used and are available from local stocks.

Dimensions

All dimensions in this catalog are for reference purposes only. Consult factory for certified dimensions.

Installation: Keyed Hollow Shaft

Mounting procedure:

1. Smear the surface of the shaft (e) with molybdenum disulfide compound. See Fig. 5.38.
2. Turn nut (b) and slide the reducer over the driven shaft. Install spacer (c) if necessary.
3. After mounting the reducer on the shaft, install bolt (f) and washer. See Fig. 5.39.

NOTE: The bore should be protected by a cover (g).

4. If the driven shaft does not have a shoulder, a spacer (h) should be used. See Fig. 5.40.

Removal procedure:

1. Remove mount bolt (n). Attach bolt (j) to spacer (d) and turn bolt (j) to remove the hollow shaft from the driven shaft. See Fig. 5.41.

NOTE: Parts a through j and n are not provided by Sumitomo.

Fig. 5.38

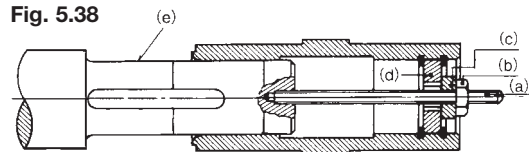

Fig. 5.39

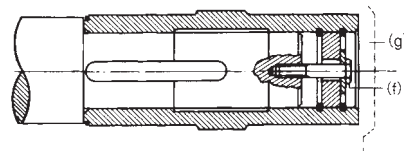

Fig. 5.40

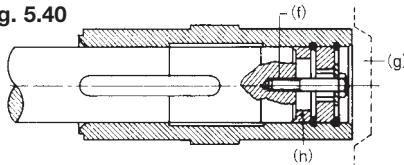
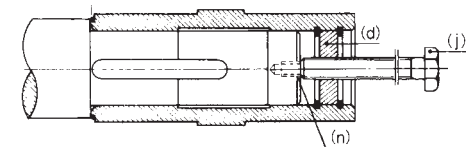

Fig. 5.41



Warranty

Sumitomo warrants that its Cyclo® BBB Speed Reducers will deliver their continuous catalog ratings and up to 300% intermittent SHOCK LOAD CAPACITY, provided they are properly installed, maintained and operated within the limits of speed, torque or other load conditions under which they were sold. Sumitomo further states that Cyclo® BBB Speed Reducers are warranted to be free from defects in material or workmanship for a period of two years from the date of shipment. Sumitomo assumes no liability beyond product repair or replacement under this limited warranty.

For construction purposes, be sure to obtain certified dimension sheets or drawings. Although we take every precaution to include accurate data in our catalog, we cannot guarantee such accuracy. If performance guarantees are required, they should be obtained in writing from the factory. Full consideration will be given to such requests when complete details are given of the proposed installation.

Bottling/Baking

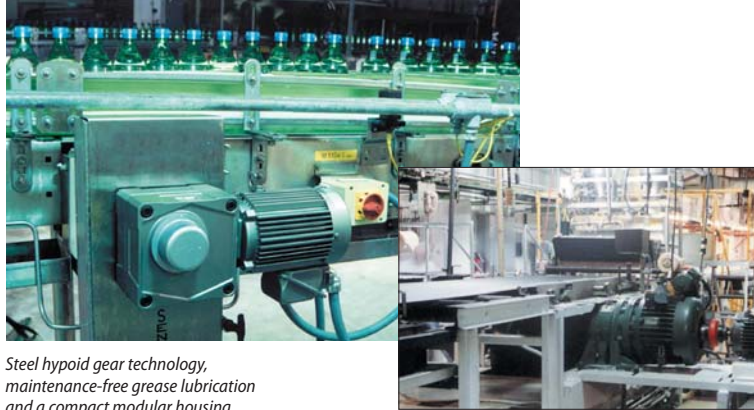

Steel hypoid gear technology, maintenance-free grease lubrication and a compact modular housing makes the Hyponic® an efficient performer in the food industry.

A 15-hp Beier mechanical variable speed drive with electric remote control provides an adjustable, steady speed range for this 350-ft. oven band conveyor.

Water Treatment



Each of these Sumitomo Paramax® speed reducers helps pump up to 13 million gallons a day at this state-of-the-art wastewater treatment facility in the City of Clearwater, Florida.

Cyclo® mixer drives are a key component of this award-winning water treatment facility in Hillsborough County, Florida.

Material Handling



Sumitomo Paramax® reducers provide quiet, reliable operation for both the hoist and trolley drive systems in this 35-ton capacity DC Trolley Hoist used for heavy-duty coil handling service.



Custom Designs



In less than 20 minutes, 96 Sumitomo Cyclo® Bevel Buddybox gearmotors help retract the 13,000-ton roof on Seattle's new Safeco Field.



The Sumitomo gearmotors, on eight travel truck assemblies, turn 128 36" wheels.

Wood Products

Sumitomo Cyclo® drives are an integral part of this manufacturing plant which produces 150,000 board feet of unfinished strip and plank hardwood flooring each week.



Once flooring is side-matched, it is inspected for defects. This conveyor, driven by Sumitomo Cyclo® drives, carries defective material to the hammer mill.

Steel

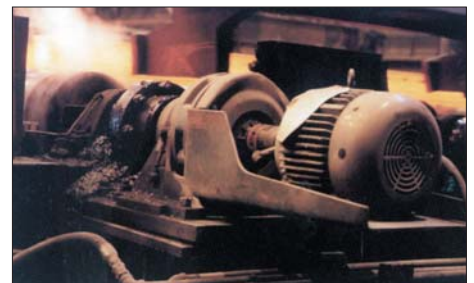

After molten steel is formed in the five-strand continuous caster at this steel mill, it is conveyed by Sumitomo Cyclo® drives on the auto-torch conveyors where the steel is cut into billets.

WORLDWIDE LOCATIONS

Sumitomo Machinery Corporation of America

Headquarters & Manufacturing

4200 Holland Boulevard
Chesapeake, VA 23323
Tel: 757-485-3355 • Fax: 757-485-3075

www.sumitomodrive.com
E-mail: marketing@suminet.com

U.S. Sales and Support

Mid-West
Sumitomo Machinery Corporation of America
175 West Lake Drive
Glendale Heights, IL 60139
Tel: 630-752-0200 • Fax: 630-752-0208

West
Sumitomo Machinery Corporation of America
2375 Railroad Street
Corona, CA 92880-5411
Tel: 951-340-4100 • Fax: 951-340-4108

Southwest
Sumitomo Machinery Corporation of America
1420 Halsey Way #130
Carrollton, TX 75007
Tel: 972-323-9600 • Fax: 972-323-9308

Canada

Toronto (East)
SM-Cyclo of Canada, Ltd.
870 Equestrian Court
Oakville, Ontario, Canada L6L 6L7
Tel: 905-469-1050 • Fax: 905-469-1055

Vancouver (West)
SM-Cyclo of Canada, Ltd.
740 Chester Road, Annacis Island, Delta
B.C., Canada V3M 6J1
Tel: 604-525-5403 • Fax: 604-525-0879

Montreal
SM-Cyclo of Canada, Ltd.
226 Mignerons Street
St. Laurent, Quebec, Canada H4T 1Y7
Tel: 514-340-1300 • Fax: 514-340-1343

World Headquarters

Japan
Sumitomo Heavy Industries, Ltd.
Power Transmission & Controls Group
5-9-11, KITA-Shinagawa, Shinagawa-Ku
Tokyo 141-8686 Japan
Tel: 011-813-5488-8363 • Fax: 011-813-5488-8365

For Worldwide contact information:
www.sumitomodrive.com



Mexico

Monterrey
SM-Cyclo de Mexico, S.A. de C.V.
Calle "C" No. 506A
Parque Industrial Almacentro
Apodaca, N.L., Mexico 66600
Tel: 011-52-81-8144-5130 • Fax: 011-52-81-8369-3699

Mexico City
SM-Cyclo de Mexico, S.A. de C.V.
Privada Ceylan No. 59-B Bis
Colonia Industrial Vallejo
Delegación Azcapotzalco, DF Mexico 02300
Tel: 011-52-55-5368-7172 • Fax: 011-52-55-5368-6699

South America

Brazil
SM-Cyclo Redutores do Brasil Ltda.
Av. Fagundes Filho, 191
Ed. Houston Office Center - Rm. 123
CEP: 04304-000 - São Paulo, Brazil
Tel: 011-55-11-5585-3600 • Fax: 011-55-11-5585-9990

Chile
SM-Cyclo de Chile Ltda.
San Pablo 3507
Comuna de Quinta Normal - Santiago, Chile
Tel: 011-562-786-6963 • Fax: 011-562-786-6964

Argentina
SM-Cyclo de Argentina SA
Manuel Montes de Oca 6719
B1601BMG, Munro
Buenos Aires, Argentina
Tel: 011-54-11-4765-5332 • Fax: 011-54-11-4765-5517

Europe

Austria
Belgium
France
Germany
Italy
Netherlands
Spain
Sweden
Switzerland

Asia

China
Hong Kong
Indonesia
Korea
Malaysia
Philippines
Taiwan
Thailand

Other Locations

Australia
India
New Zealand
South Africa